

C.4.4 REFRIGERANT SYSTEM DIAGRAM

C.4.4.1 Inverter Heat Pump

MXZ-2F33VF3

Unit: mm

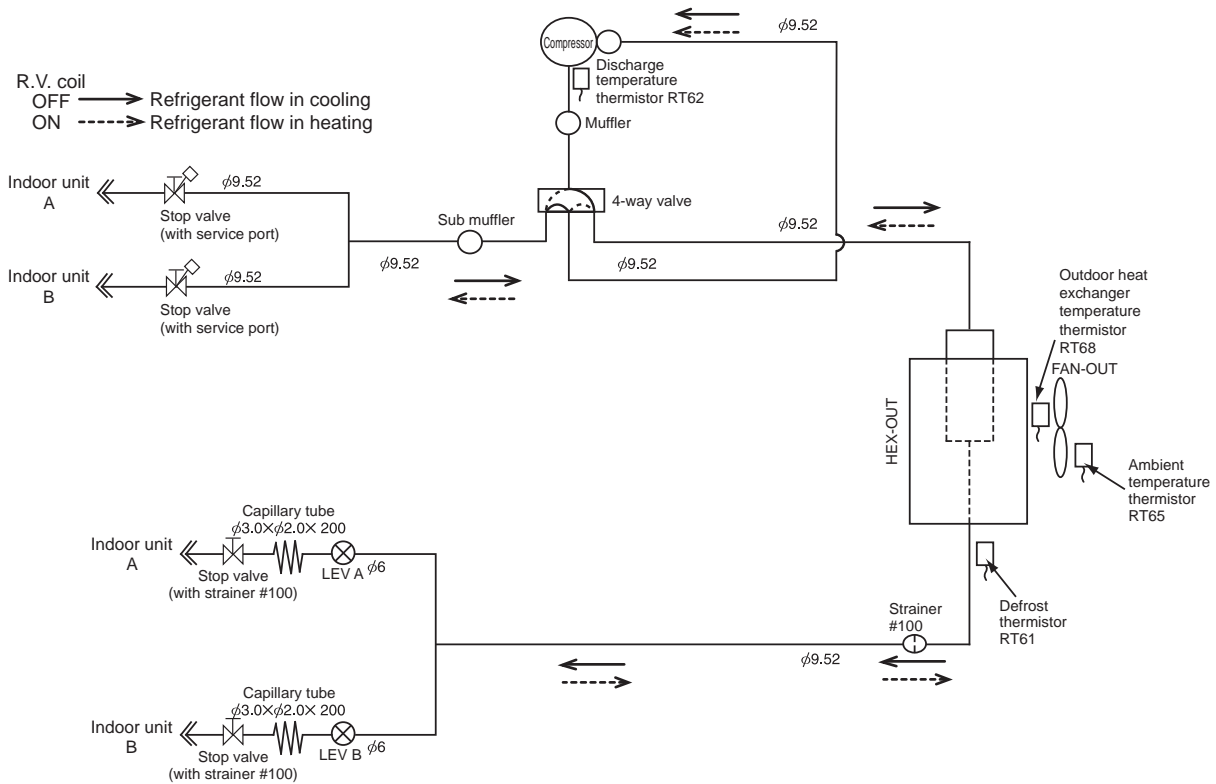

MXZ-2F42VF3 MXZ-2F53VF3 **MXZ-2F53VVFH3** MXZ-2HA40VF MXZ-2HA50VF

Unit: mm

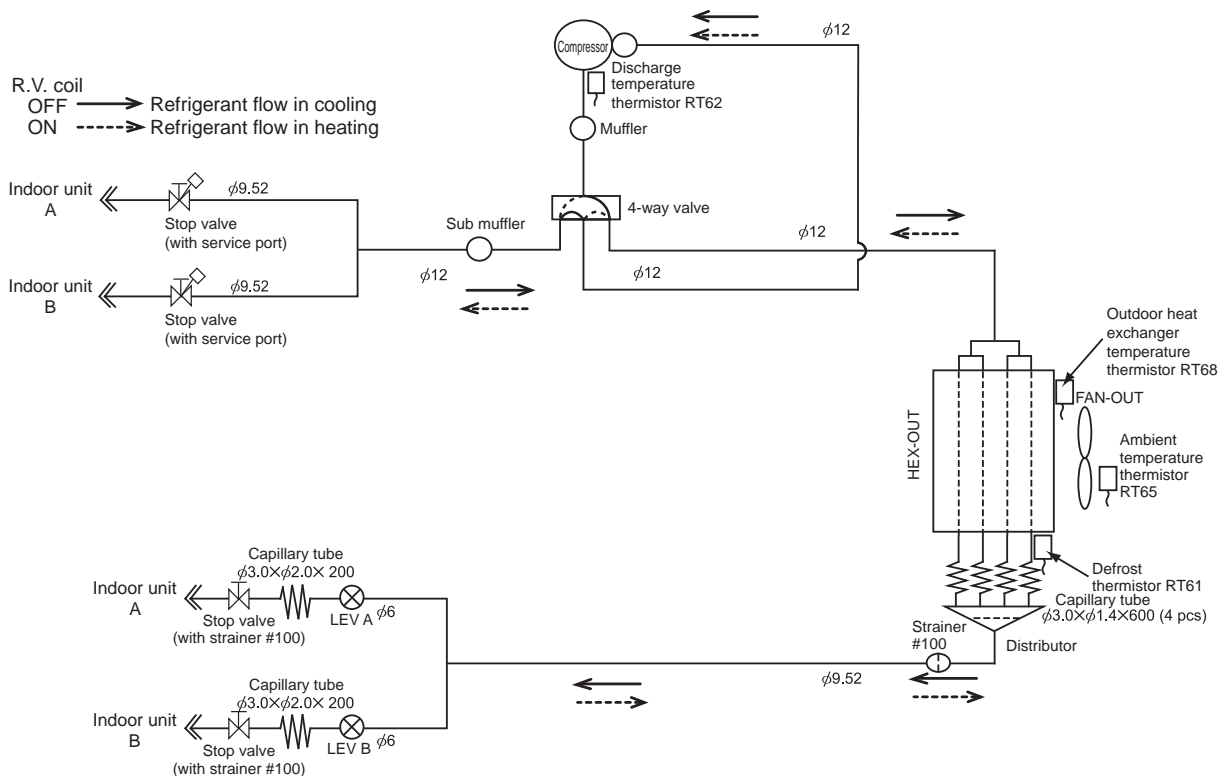

REFRIGERANT SYSTEM DIAGRAM MULTI SYSTEMS

MXZ-4F83VF

UNIT: mm

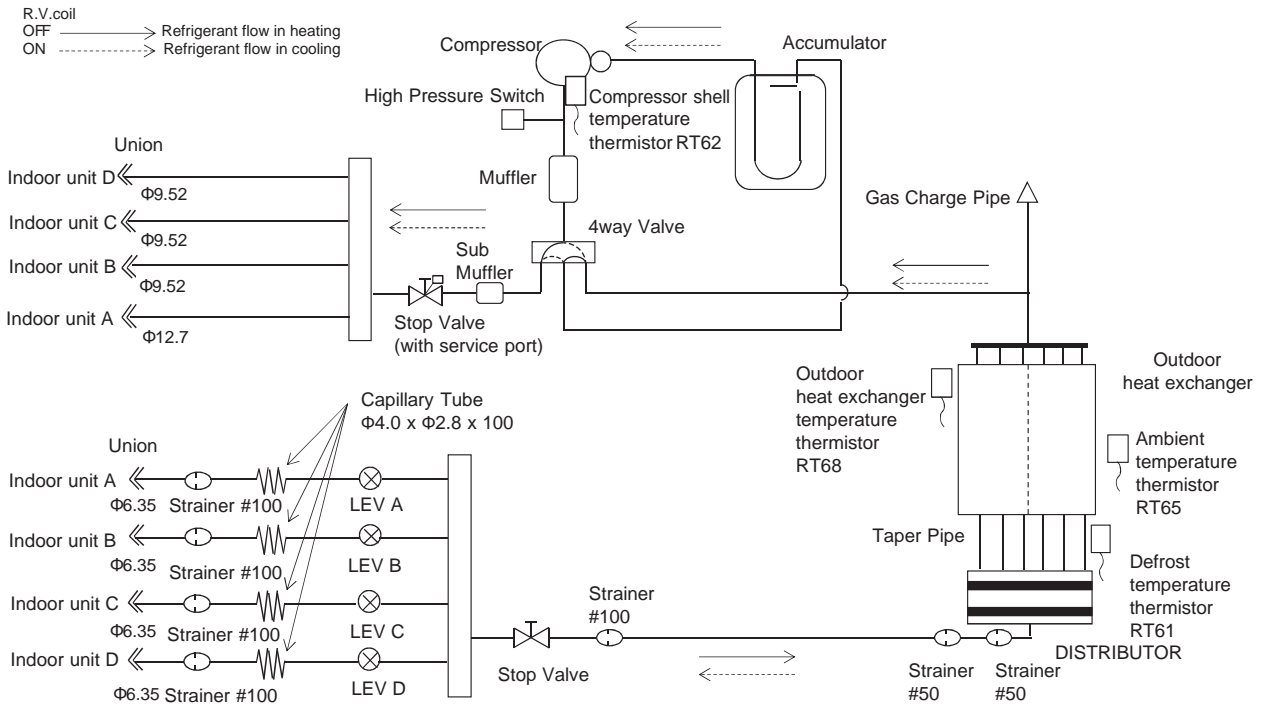

MXZ-5F102VF

UNIT: mm

