

# Air Conditioning Control System

## Centralized Controller

### AE-200A/AE-50A/EW-50A

### AE-200E/AE-50E/EW-50E

## Instruction Book

### –BACnet<sup>®</sup> function–



### Contents

Safety precautions.....	2
1. Parts to be used .....	4
1-1. Required parts.....	4
1-2. Separately sold parts .....	4
1-3. Commercially available parts .....	4
2. Before use.....	5
2-1. Introduction .....	5
2-2. License.....	5
2-3. Models of units that can be controlled with BACnet <sup>®</sup> .....	6
2-4. Restrictions and cautions.....	6
3. Usage (System configurations).....	7
3-1. Sample system configurations .....	7
3-2. Group configurations.....	10
4. Usage (Communication specifications).....	11
4-1. BACnet <sup>®</sup> specifications.....	11
4-2. Communication protocol specifications.....	11
4-3. Objects .....	12
4-4. Services .....	14
4-5. Services for each object.....	16
5. Usage (Function specifications).....	17
5-1. Controller functions and BACnet <sup>®</sup> functions.....	17
5-2. Basic functions .....	19
5-3. Set temperature objects .....	25
5-4. "System Forced Off" forced-reset function .....	25
5-5. Apportioned electricity billing function .....	26
5-6. Alarm Signal .....	30
5-7. Event service specifications .....	31
5-8. BACnet <sup>®</sup> information and storage timing/cycle in nonvolatile memory within the AE-200/AE-50/EW-50 .....	33
6. Usage (AE-200/AE-50/EW-50 BACnet <sup>®</sup> connection mode).....	34
6-1. AE-200/AE-50/EW-50 BACnet <sup>®</sup> connection mode .....	34
7. Checking installation operations and performing trial run .....	35
7-1. Flow of initial settings .....	35
7-2. Preparatory items for initial settings.....	37
7-3. Step-1 Initial settings for the air conditioning system .....	38
7-4. Step-2 Trial run of the air conditioning system .....	40
7-5. Step-3 Initial settings for the BACnet <sup>®</sup> related items .....	41
7-6. Step-4 Trial run of BACnet <sup>®</sup> function .....	42
7-7. When changing settings or reconfiguring AE-200/AE-50/ EW-50 .....	55
Appendix: Added functions .....	57

Before using the controller, please read this Instruction Book carefully to ensure proper operation. Retain this manual for future reference. BACnet<sup>®</sup> is a registered trademark of ASHRAE (American Society of Heating, Refrigerating and Air-Conditioning Engineers, INC.).

# Safety precautions

- ▶ Observe these precautions carefully to ensure safety.
- ▶ After reading this manual, pass the manual on to the end user to retain for future reference.
- ▶ The user should keep this manual for future reference and refer to it as necessary. This manual should be made available to those who repair or relocate the units. Make sure that the manual is passed on to any future air conditioning system user.

 <b>WARNING</b>	: indicates a hazardous situation which, if not avoided, could result in death or serious injury.
 <b>CAUTION</b>	: indicates a hazardous situation which, if not avoided, could result in minor or moderate injury.
<b>CAUTION</b>	: addresses practices not related to personal injury, such as product and/or property damage.

## General precautions

### **WARNING**

Do not install the controller in areas where large amounts of oil, steam, organic solvents, or corrosive gases (such as ammonia, sulfuric compounds, or acids), or areas where acidic/alkaline solutions or special chemical sprays are used frequently. These substances may significantly reduce the performance and corrode the internal parts, resulting in electric shock, malfunction, smoke, or fire.

To reduce the risk of short circuits, current leakage, electric shock, malfunction, smoke, or fire, do not wash the controller with water or any other liquid.

To reduce the risk of electric shock, malfunction, smoke, or fire, do not touch the electrical parts, USB memory, or touch panel with wet fingers.

To reduce the risk of injury or electric shock, before spraying a chemical around the controller, stop the operation and cover the controller.

To reduce the risk of injury, keep children away while installing, inspecting, or repairing the controller.

If you notice any abnormality (e.g., burning smell), stop the operation, turn off the controller, and consult your dealer. Continuing the operation may result in electric shock, malfunction, or fire.

Properly install all required covers to keep moisture and dust out of the controller. Dust accumulation and the presence of water may result in electric shock, smoke, or fire.

### **CAUTION**

To reduce the risk of fire or explosion, do not place flammable materials or use flammable sprays around the controller.

To reduce the risk of electric shock or malfunction, do not touch the touch panel, switches, or buttons with a sharp object.

To avoid injury from broken glass, do not apply excessive force to the glass parts.

---

To reduce the risk of injury, electric shock, or malfunction, avoid contact with the sharp edges of certain parts.

---

Consult your dealer for the proper disposal of the controller. Improper disposal will pose a risk of environmental pollution.

## Precautions for relocating or repairing the unit

### **WARNING**

The controller must be repaired or moved only by qualified personnel. Do not disassemble or modify the controller. Improper installation or repair may result in injury, electric shock, or fire.

## Additional precautions

### **CAUTION**

To avoid discoloration, do not use benzene, thinner, or chemical rag to clean the controller. When the controller is heavily soiled, wipe the controller with a well-wrung cloth that has been soaked in water with mild detergent, and then wipe off with a dry cloth.

This appliance is not intended for use by persons (including children) with reduced physical, sensory or mental capabilities, or lack of experience and knowledge, unless they have been given supervision or instruction concerning use of the appliance by a person responsible for their safety. Children should be supervised to ensure that they do not play with the appliance.

## Terms used in this manual

- "Centralized Controller AE-200A/AE-200E" is referred to as "AE-200".
- "Centralized Controller AE-50A/AE-50E" is referred to as "AE-50".
- "Centralized Controller EW-50A/EW-50E" is referred to as "EW-50".
- "PI controller (PAC-YG60MCA)" is referred to as "PI controller".
- "AI controller (PAC-YG63MCA)" is referred to as "AI controller".
- "OA Processing Unit (LOSSNAY with heater and humidifier)" is referred to as "OA Processing Unit".
- "e-Series chiller unit (EAHV, EACV)" is referred to as "Chiller unit".
- "Chiller unit of MEHITS" is referred to as "MEHT-CH&HP unit".

# 1. Parts to be used

## 1-1. Required parts

Obtain the items listed below from your dealer before using this function.

No.	Item	Remarks
1	AE-200/AE-50/EW-50 Instruction Book (BACnet <sup>®</sup> function)	This manual
2	“BACnet connection” license for AE-200/AE-50/EW-50	Required for each AE-200/AE-50/EW-50 that connects to BACnet <sup>®</sup> .
3	BACnet <sup>®</sup> Setting Tool	Used for configuring BACnet <sup>®</sup> function for AE-200/AE-50/EW-50.
4	Software update file	Used for updating the AE-200/AE-50/EW-50 to the latest version. The versions of all AE-200/AE-50/EW-50 that connect to BACnet <sup>®</sup> must be the same.

The items listed above are essential to use the BACnet<sup>®</sup> function. For equipment that are required for initial settings and trial runs of the BACnet<sup>®</sup> function, refer to section 7-2 “Preparatory items for initial settings”. When using the apportioned electricity billing function with the BACnet<sup>®</sup> function, the parts that are used for the apportioned electricity billing function are also required. For details, refer to the AE-200/AE-50/EW-50 Instruction Book (Apportioned Electricity Billing Function).

## 1-2. Separately sold parts

None.

When using the apportioned electricity billing function with the BACnet<sup>®</sup> function, the parts that are used for the apportioned electricity billing function are also required. For details, refer to the AE-200/AE-50/EW-50 Instruction Book (Apportioned Electricity Billing Function).

## 1-3. Commercially available parts

Where necessary, prepare the commercially available parts listed below.

	Item	Qty	Remarks
Communication item	LAN cable	As appropriate	Category 5 or above straight cable (Max. 100 m (328 ft)) *1
	Switching HUB	Required number	100 BASE-TX-compatible

\*1 If the LAN cable is to be longer than 100 m, pass this through a switching HUB.

When using the apportioned electricity billing function with the BACnet<sup>®</sup> function, the parts that are used for the apportioned electricity billing function are also required. For details, refer to the AE-200/AE-50/EW-50 Instruction Book (Apportioned Electricity Billing Function).

## 2. Before use

This manual explains how to use the AE-200/AE-50/EW-50 BACnet® function.

For how to install AE-200/AE-50/EW-50 or how to use the functions other than the BACnet® function, refer to the AE-200/AE-50/EW-50 Installation Manual and Instruction Book.

For how to use the BACnet® Setting Tool, refer to the AE-200/AE-50/EW-50 Instruction Book (BACnet® Setting Tool).

When using the apportioned electricity billing function with the BACnet® function, refer to the AE-200/AE-50/EW-50 Instruction Book (Apportioned Electricity Billing Function) and the AE-200/AE-50/EW-50 Instruction Book (BACnet® Apportioned Electricity Billing Function Trial Run).

### 2-1. Introduction

The AE-200/AE-50/EW-50 BACnet® function can be used when connecting AE-200/AE-50/EW-50 to the open network BACnet® that is used for the building management system.

The air conditioning units connected to AE-200/AE-50/EW-50 can be monitored and operated not only from the existing web browser or the AE-200/AE-50's LCD, but also from the building management system using the BACnet® communication protocol.

**Note**

The explanation of the BACnet® function in this manual is based on the specification of AE-200/AE-50/EW-50 software version 7.70.

### 2-2. License

The licenses related to the AE-200/AE-50/EW-50 BACnet® function are as follows.

License name	Requirement condition	Required number and remarks
"BACnet connection"	Required when using the BACnet® function	One license is required for each AE-200/AE-50/EW-50 that connects to BACnet®.
"Charge"	Required when using the apportioned electricity billing function	One license is required for the AE-200 that is used for electricity apportioning and each AE-50/EW-50 that connects to the AE-200.

## 2-3. Models of units that can be controlled with BACnet®

The table below shows models that can connect to AE-200/AE-50/EW-50, and models that can be controlled with the BACnet® function.

V: Connectable/Controllable  
 —: Not connectable/Not controllable

Model		Connectable/Not connectable to AE-200/AE-50/EW-50	Controllable/Not controllable with BACnet®
CITY MULTI	S series	V	V
	Y series	V	V
	HP series	V	V
	R2 series	V	V
	WY series	V	V
	WR2 series	V	V
	HVRF series	V	V
Air conditioning unit with outlet air temperature control		V	V
LOSSNAY		V	V (Only when groups are configured.)
OA Processing Unit		V	V (Only when groups are configured.)
Air To Water Booster unit/Air To Water (PWFY)		V	V
A-control unit (Mr. Slim)		An adapter is required.	V
K-control unit		—	—
Room air conditioner (RAC)		An interface is required.	V
Hot Water Heat Pump unit (CAHV, CRHV, QAHV)		V	—
Chiller unit		V	—
MEHT-CH&HP unit		V	—
DIDO controller (PAC-YG66DCA)		V	—
PI controller (PAC-YG60MCA)		V	V
AI controller (PAC-YG63MCA)		V	—

## 2-4. Restrictions and cautions

Restrictions and cautions for AE-200/AE-50/EW-50 BACnet® functions are as follows.

### (1) Action to take when an error occurs

Immediately carry out repairs to the problem area when an error related to air conditioning units is detected on the building management system.

### (2) Functions

Due to continuing improvement, specifications are subject to change without notice.

### (3) Request interval

When sending “ReadProperty” or “WriteProperty” from the building management system to the AE-200/AE-50/EW-50, set the interval to 200 (ms/property) or above.

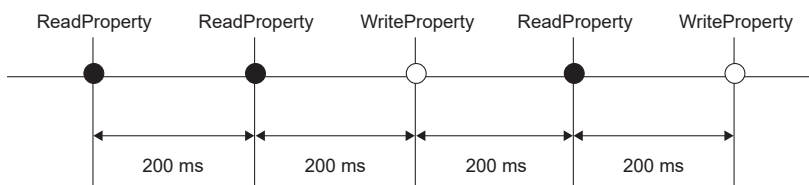

When sending 10 properties using “ReadPropertyMultiple”, wait for at least 2000 ms (= 200 ms × 10 properties) before sending another request to the AE-200/AE-50/EW-50.

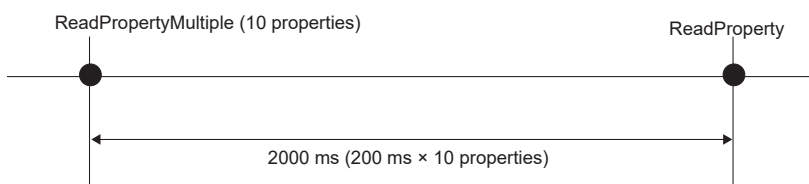

# 3. Usage (System configurations)

## 3-1. Sample system configurations

(1) When controlling 50 or fewer units of equipment and not using an apportioned electricity billing function

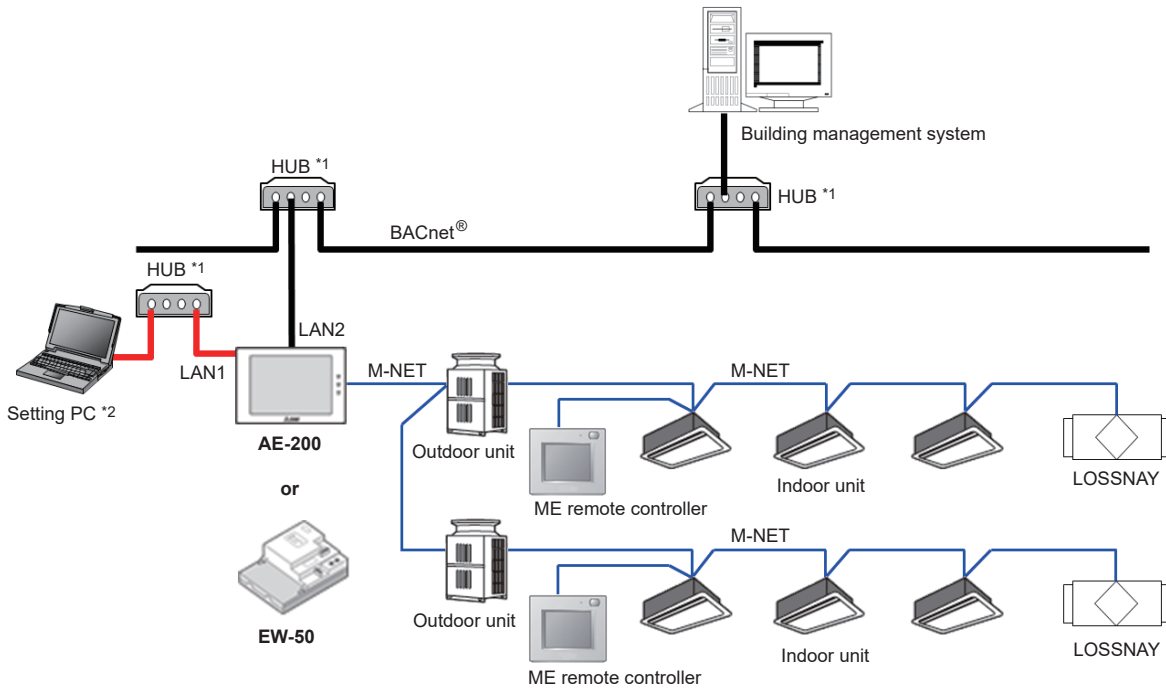

\*1 Use a switching HUB to connect to LAN1 and LAN2 (BACnet®). Do not connect LAN1 and LAN2 (BACnet®) to the same HUB.

\*2 A PC (hereafter referred to as Setting PC) is required to make settings for the AE-200/EW-50 BACnet® functions. After making settings, disconnect the Setting PC as well as LAN cables and HUBs used to connect to the Setting PC from the AE-200/EW-50. Refer to section 7 "Checking installation operations and performing trial run" for details.

**(2) When controlling more than 50 units of equipment \*3 and not using an apportioned electricity billing function**

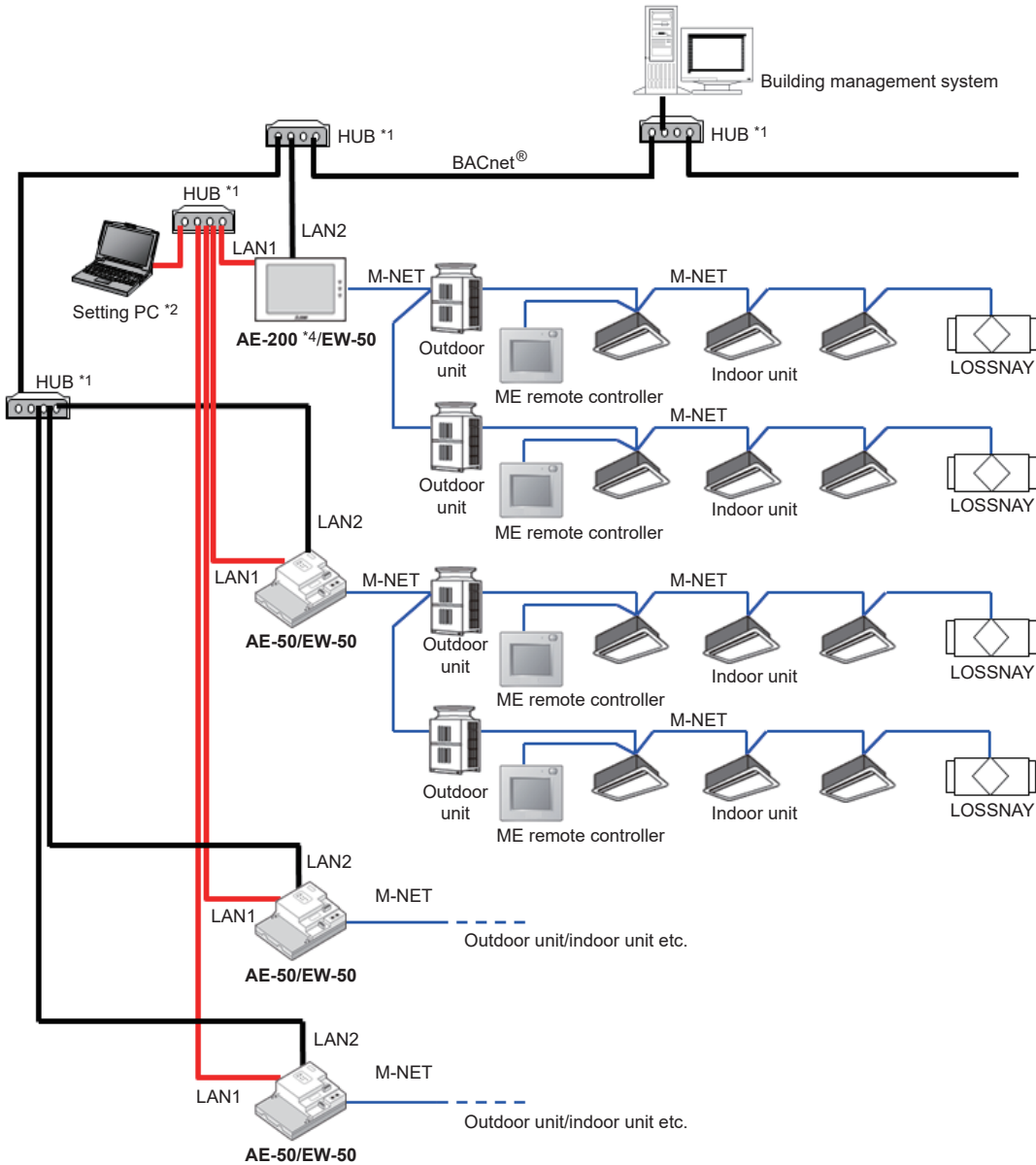

- \*1 Use a switching HUB to connect to LAN1 and LAN2 (BACnet®). Do not connect LAN1 and LAN2 (BACnet®) to the same HUB.
- \*2 A PC (hereafter referred to as Setting PC) is required to make settings for the AE-200/AE-50/EW-50 BACnet® functions. After making settings, disconnect the Setting PC from the AE-200/AE-50/EW-50. Refer to section 7 "Checking installation operations and performing trial run" for details.
- \*3 Up to 50 units of equipment can be connected to and controlled by each AE-200/AE-50/EW-50. If performing centralized control with an AE-200, up to 3 AE-50/EW-50 can be connected to a single AE-200 (if not using AE-200 M-NET, up to 4 can be connected).
- \*4 If performing centralized control with an AE-200, because time synchronization from the building management system comes through the AE-200, then for systems including those that do not have BACnet® control functions, configure so that AE-200 is connected to the BACnet®, by connecting devices to control with BACnet® to the AE-200.



**(3) When using an apportioned electricity billing function \*4**

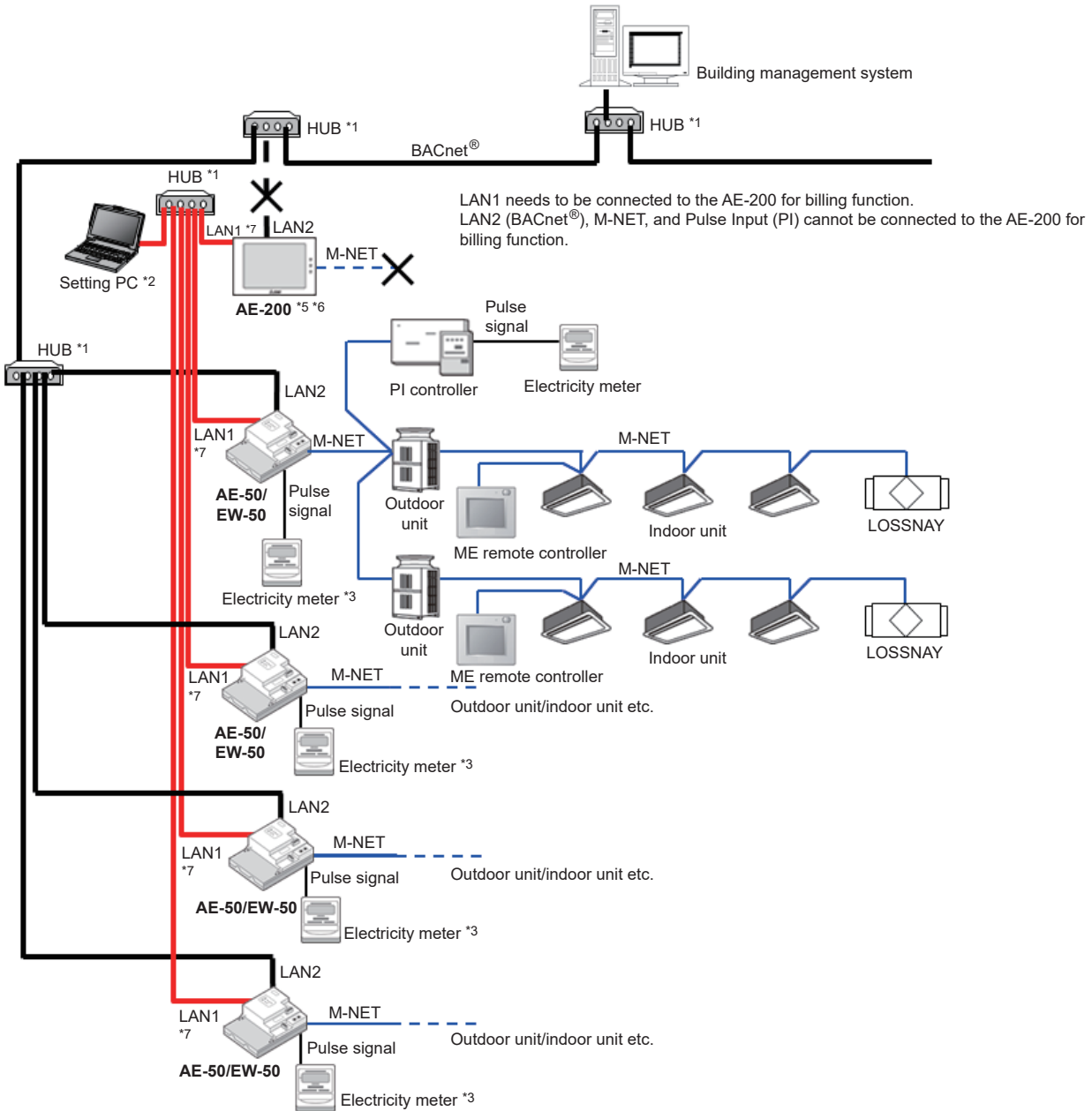

- \*1 Use a switching HUB to connect to LAN1 and LAN2 (BACnet®). Do not connect LAN1 and LAN2 (BACnet®) to the same HUB.
- \*2 A PC (hereafter referred to as Setting PC) is required to make settings for the AE-50/EW-50 BACnet® functions. After making settings, disconnect the Setting PC from the AE-50/EW-50. Refer to section 7 "Checking installation operations and performing trial run" for details.
- \*3 If using the apportioned electricity billing function, we recommend that instead of using the AE-50/EW-50 built-in Pulse Input (PI), the PI controller be used for measurement of electric energy.  
(If AE-50/EW-50 built-in Pulse Input (PI) is used, pulse input will not be possible when the AE-50/EW-50 is stopped, during power outages or during software updates. This could result in discrepancies between the measurements and the actual electric energy consumed.)  
When using the AE-50/EW-50 built-in Pulse Input (PI), approve the above-mentioned restrictions for the customer and then use.
- \*4 Up to 50 units of equipment can be connected to and controlled by each AE-50/EW-50. Up to 4 AE-50/EW-50 controllers can be connected to each AE-200 for billing function.
- \*5 To use an apportioned electricity billing function and perform date and time synchronization from the building management system, set the "Time Master/Sub" setting to "Sub" on the AE-200 for billing function and synchronize the time from AE-50/EW-50 connected to BACnet®. The "Time Master/Sub" setting can be made on the Initial Setting Tool or AE-200/AE-50's LCD. (Refer to the AE-200/AE-50/EW-50 Instruction Book (Initial Settings) for settings methods.)
- \*6 If using the apportioned electricity billing function, connection of M-NET and Pulse Input (PI) to the AE-200 for billing function is prohibited. Accordingly, the AE-200 for billing functions does not have any BACnet® control devices, and BACnet® connection is not necessary. As a result, BACnet® settings and "BACnet connection" license are not required for the AE-200 for billing function.
- \*7 If using the apportioned electricity billing function, connection of LAN1 for transfer of power apportioning information is required.

### 3-2. Group configurations

The basic functions of the BACnet® function can be performed for each unit group.  
Multiple indoor units (ICs) in a group can collectively be controlled.  
The group number is a range of 1 to 50.

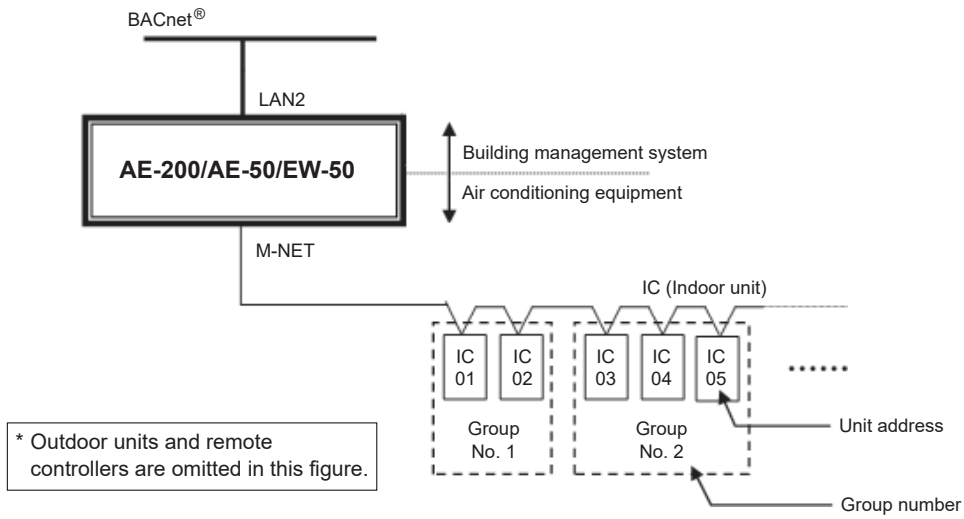

# 4. Usage (Communication specifications)

## 4-1. BACnet<sup>®</sup> specifications

BACnet<sup>®</sup> communication specifications are based on ANSI/ASHRAE Standard 135-2010.

## 4-2. Communication protocol specifications

### (1) Overview of protocol

- Use BACnet<sup>®</sup>/IP based on ANSI/ASHRAE Standard 135-2010 on UDP/IP of Ethernet<sup>®</sup>\*
- LAN2 is used to connect BACnet<sup>®</sup>.

Ether header	IP header	UDP header	BVLL header	NPCI header	APDU
--------------	-----------	------------	-------------	-------------	------

\* Ethernet<sup>®</sup> is a registered trademark of Xerox Corporation in the United States.

### (2) Ether header

The physical layer is Ethernet<sup>®</sup> and the specifications are 100BASE-TX.

### (3) IP header

A Class C private address is recommended \*1. The sub-net mask is 255. 255. 255. 0.

\*1 Recommended values (range): [192.168.2.1] to [192.168.254.254]

[192.168.0.0] and [192.168.255.255] should not be used for a LAN2 IP address.

An IP address set using LAN1 should not be used as a LAN2 IP address.

LAN1 and LAN2 network addresses must not be the same.

### (4) UDP header

47808 (0xBAC0) is recommended for the default UDP port for unicast and broadcast.

### (5) BVLL header

BVLC type (1 octet): 0x81 fixed (BVLL for BACnet<sup>®</sup>/IP)

BVLC function (1 octet): 0x0A for unicast

0x0B for broadcast

BVLC length (2 octets): Variable (BVLL header (4) + APDU data length)

(The above is a typical example. For details, refer to ANSI/ASHRAE Standard 135-2010.)

### (6) BACnet<sup>®</sup> NETWORK NPCI header

Version (1 octet): 0x01 fixed

Control (1 octet): 0x04 with response message

0x00 without response message

(The above is a typical example. For details, refer to ANSI/ASHRAE Standard 135-2010.)

### (7) APDU for BACnet<sup>®</sup>

Data of 1,024 octets and under.

(Refer to ANSI/ASHRAE Standard 135-2010 for details.)

## 4-3. Objects

Support status for objects and for BACnet® functions are listed below.

V: Supported  
—: Not supported

Object type *1	Abbreviation	Supported/ Not supported	Object
Access Credential (32)	—	—	
Access Door (30)	—	—	
Access Point (33)	—	—	
Access Rights (34)	—	—	
Access User (35)	—	—	
Access Zone (36)	—	—	
Accumulator (23)	AC	V	Group Apportioned Electric Energy Interlocked Units Apportioned Electric Energy Plcontroller Electric Energy 1–4 Pulse Input Electric Energy 1–4 Group Apportionment Parameter Interlocked Units Apportionment Parameter
Analog Input (0)	AI	V	Room Temp [Water Temp] Error Code Detail
Analog Output (1)	—	—	
Analog Value (2)	AV	V	Set Temp [Set Water Temp] Set Temp Cool Set Temp Heat Set Temp Auto Set High Limit Setback Temp Set Low Limit Setback Temp
Averaging (18)	—	—	
Binary Input (3)	BI	V	On Off State Alarm Signal *2 Filter Sign [Circulating Water Exchange Sign] M-NET Communication State Night Purge State Thermo On Off State System Alarm Signal *2 External Heat Source State Plcontroller Alarm Signal *2
Binary Output (4)	BO	V	On Off Setup *3
Binary Value (5)	BV	V	Filter Sign Reset [Circulating Water Exchange Sign Reset] Prohibition On Off *3 Prohibition Mode Prohibition Filter Sign Reset [Prohibition Circulating Water Exchange Sign Reset] Prohibition Set Temperature Prohibition Fan Speed System Forced Off (individual)/(collective) *4
BitString Value (39)	—	—	
Calendar (6)	—	—	
CharacterString Value (40)	—	—	
Command (7)	—	—	
Credential Data Input (37)	—	—	
Date Pattern Value (41)	—	—	
Date Value (42)	—	—	
DateTime Pattern Value (43)	—	—	
DateTime Value (44)	—	—	
Device (8)	DEV	V	Device object of AE-200/AE-50/EW-50
Event Enrollment (9)	—	—	
Event Log (25)	—	—	

Object type *1	Abbreviation	Supported/ Not supported	Object
File (10)	—	—	
Global Group (26)	—	—	
Group (11)	—	—	
Integer Value (45)	—	—	
Large Analog Value (46)	—	—	
Life Safety Point (21)	—	—	
Life Safety Zone (22)	—	—	
Load Control (28)	—	—	
Loop (12)	—	—	
Multi-state Input (13)	MI	V	Error Code Operational Mode State Fan Speed State Air Direction State Ventilation Mode State Air To Water Mode State
Multi-state Output (14)	MO	V	Operational Mode Setup Fan Speed Setup Air Direction Setup Ventilation Mode Setup Air To Water Mode Setup
Multi-state Value (19)	—	—	
Network Security (38)	—	—	
Notification Class (15)	CLS	V	Notification Class
OctetString Value (47)	—	—	
Positive Integer Value (48)	—	—	
Program (16)	—	—	
Pulse Converter (24)	—	—	
Schedule (17)	—	—	
Structured View (29)	—	—	
Time Pattern Value (49)	—	—	
Time Value (50)	—	—	
Trend Log (20)	LOG	V	Trend Log Room Temp Trend Log Group Apportioned Electric Energy Trend Log Interlocked Units Apportioned Electric Energy Trend Log PIcontroller Electric Energy 1–4 Trend Log Pulse Input Electric Energy 1–4 Trend Log Group Apportionment parameter Trend Log Interlocked Units Apportionment parameter
Trend Log Multiple (27)	—	—	

\*1 Values within parentheses are "Object\_Type" property values.

\*2 Outputs an error code (4-digit) in Description and Message Text of event notification.

\*3 Do not use this when "External Input Setting" for AE-200/AE-50/EW-50 is set to "ON/OFF (Level signal)". "External Input Setting" can be configured on the Initial Setting Tool or AE-200/AE-50's LCD. (Refer to the AE-200/AE-50/EW-50 Instruction Book (Initial Settings) for settings methods.)

\*4 Executes the stop command and remote controller operation prohibition (run/stop) command for air conditioning units.

## 4-4. Services

The BACnet<sup>®</sup> service support status is shown below.

V: Supported  
 —: Not supported  
 Initiate request: Provides services  
 Execute request: Receives and uses services

Service	Initiate request	Execute request
<b>1. Alarm and Event Services</b>		
(1) Acknowledge Alarm Service	—	—
(2) ConfirmedCOVNotification Service	V	—
(3) ConfirmedEventNotification Service	V	—
(4) GetAlarmSummary Service	—	—
(5) GetEnrollmentSummary service	—	—
(6) GetEventInformation Service	—	V
(7) LifeSafetyOperation Service	—	—
(8) SubscribeCOV Service *1	—	V
(9) SubscribeCOVProperty Service	—	—
<b>2. File Access Services</b>		
(1) AtomicReadFile Service	—	—
(2) AtomicWriteFile Service	—	—
<b>3. Object Access Services</b>		
(1) AddListElement Service	—	V
(2) RemoveListElement Service	—	V
(3) CreateObject Service	—	—
(4) DeleteObject Service	—	—
(5) ReadProperty Service	—	V
(6) ReadPropertyConditional Service	—	—
(7) ReadPropertyMultiple Service	—	V
(8) ReadRange Service	—	V
(9) WriteProperty Service	—	V
(10) WritePropertyMultiple Service	—	V
<b>4. Remote Device Management Services</b>		
(1) DeviceCommunicationControl Service	—	—
(2) ConfirmedPrivateTransfer Service	—	—
(3) ConfirmedTextMessage Service	—	—
(4) ReinitializeDevice Service	—	—
<b>5. Virtual Terminal Services</b>		
(1) VT-Open Service	—	—
(2) VT-Close Service	—	—
(3) VT-Data Service	—	—
<b>6. Security Services</b>		
(1) Authenticate Service	—	—
(2) Request Key Service	—	—
<b>7. Unconfirmed Services</b>		
(1) I-Am	V	V

Service	Initiate request	Execute request
(2) I-Have	V	—
(3) UnconfirmedCOVNotification Service	V	—
(4) UnconfirmedEventNotification Service	V	—
(5) UnconfirmedPrivateTransfer Service	—	—
(6) UnconfirmedTextMessage Service	—	—
(7) TimeSynchronization Service	—	V
(8) UTCTimeSynchronization Service	—	—
(9) Who-Has	—	V
(10) Who-Is	V	V

\*1 The maximum number of COV notifications which can be registered is 3,150. However, 5 is the maximum number of COV notifications which can be registered in which Lifetime is not = 0.

## 4-5. Services for each object

The table below lists the supported services for each object.

- : Supported  
 △ : Settings can be changed on the BACnet® Setting Tool.  
 INIT: Provides services (Initiate)  
 EXEC: Receives and executes services (Execute)

Service \ Object		Device	Analog Input	Analog Value	Binary Input	Binary Output	Binary Value	Multi-State Input	Multi-State Output	Notification Class	Accumulator	Trend Log
ConfirmedCOVNotification	INIT		△	△	△	△	△	△	△			
	EXEC											
ConfirmedEventNotification	INIT		△		△	△					△	
	EXEC											
GetEventInformation	INIT											
	EXEC	○										
SubscribeCOV	INIT											
	EXEC	○										
AddListElement	INIT											
	EXEC									○		
RemoveListElement	INIT											
	EXEC									○		
ReadProperty	INIT											
	EXEC	○	○	○	○	○	○	○	○	○	○	○
ReadPropertyMultiple	INIT											
	EXEC	○	○	○	○	○	○	○	○	○	○	○
ReadRange	INIT											
	EXEC	○								○		○
WriteProperty	INIT											
	EXEC		○	○	○	○	○		○	○	○	○
WritePropertyMultiple	INIT											
	EXEC		○	○	○	○	○		○	○	○	○
I-Am	INIT	○										
	EXEC	○										
I-Have	INIT	○										
	EXEC											
UnconfirmedCOVNotification	INIT		△	△	△	△	△	△	△			
	EXEC											
UnconfirmedEventNotification	INIT		△		△	△					△	
	EXEC											
TimeSynchronization	INIT											
	EXEC	△										
Who-Has	INIT											
	EXEC	○										
Who-Is	INIT	○										
	EXEC	○										



## 5. Usage (Function specifications)

The AE-200/AE-50/EW-50 BACnet® function mutually converts communications for air conditioning equipment connected to the AE-200/AE-50/EW-50 and for BACnet® communications.

### 5-1. Controller functions and BACnet® functions

The table below lists the supported controller functions which can monitor/operate from the web browser or the AE-200/AE-50's LCD and the BACnet® functions.

V: Supported  
—: Not supported

Classification	Item	Controller function	BACnet® function	Remarks
Monitor/ Operation	On Off Setup	V	V	
	On Off State	V	V	
	Operational Mode Setup	V	V	
	Operational Mode State	V	V	
	Fan Speed Setup	V	V	
	Fan Speed State	V	V	
	Air Direction Setup	V	V	BACnet® does not support "Downblow 20%" and "Auto" settings.
	Air Direction State	V	V	BACnet® does not support "Downblow 20%" and "Auto" settings.
	Room Temp [Water Temp]	V	V	
	Set Temp [Set Water Temp]	V	V	
	Set Temp Cool	V	V	
	Set Temp Heat	V	V	
	Set Temp Auto	V	V	
	Set High Limit Setback Temp	V	V	Only AE-200A/AE-50A/EW-50A
	Set Low Limit Setback Temp	V	V	Only AE-200A/AE-50A/EW-50A
	Ventilation Mode Setup	V	V	
	Ventilation Mode State	V	V	
	Air To Water Mode Setup	V	V	
	Air To Water Mode State	V	V	
	Night Purge Setup	V	—	
	Night Purge State	V	V	
	Prohibition On Off	V	V	
	Prohibition Mode	V	V	
	Prohibition Filter Sign Reset [Prohibition Circulating Water Exchange Sign Reset]	V	V	
	Prohibition Set Temperature	V	V	
	Prohibition Timer	V	—	
	Prohibition Air Direction	V	—	
	Prohibition Fan Speed	V	V	
	System Forced Off (individual)	V	V	
	System Forced Off (collective)	V	V	
	Thermo On Off State	V *1	V *2	
	External Heat Source State	—	V	Output status of indoor unit CN24

Classification	Item	Controller function	BACnet <sup>®</sup> function	Remarks
Alarm monitor	Alarm Signal (Air conditioning unit/PI controller)	√	√	
	Error Code	√	√	Controllers support 4-digit error codes, and BACnet <sup>®</sup> supports 1- and 4-digit error codes.
	System Alarm Signal	√	√	
	M-NET Communication State	√	√	
	Filter Sign [Circulating Water Exchange Sign]	√	√	
	Filter Sign Reset [Circulating Water Exchange Sign Reset]	√	√	
Control functions	Command Failure	—	√	
	High Limit/Low Limit Alarm	√ *3	√	
	Night Setback control	√	—	
	Schedule control	√	—	
	Interlock control	√	—	
Data management functions	Energy management data/ Trend log	√	√	These are collected individually in the body/BACnet <sup>®</sup> , so sometimes the values of these do not coincide.
	Group Apportioned Electric Energy	√	√	
	Interlocked Units Apportioned Electric Energy	√	√	
	Group Apportionment Parameter	√	√	BACnet <sup>®</sup> function has only parameters for outdoor units.
	Interlocked Units Apportionment Parameter	√	√	BACnet <sup>®</sup> function has only parameters for outdoor units.
	PIcontroller Electric Energy (Ch 1-4)	√	√	
	Pulse Input Electric Energy (Metering device 1-4)	√	√	
Other functions	Unit of temperature setting	√	√	This setting on the AE-200/AE-50/EW-50 and the one on the BACnet <sup>®</sup> are different. On the BACnet <sup>®</sup> , only the unit of temperature that is used for BACnet <sup>®</sup> communication can be set.
	Cumulative operation time/ FAN operation time	√	—	
	Time management	√	√	
	BACnet <sup>®</sup> router	—	√	
	LCD lock	√	—	

\*1 Supports only Thermo-ON time, Thermo-ON/OFF count.

Thermo-ON/OFF count cannot be monitored from the AE-200/AE-50's LCD or web browser, but can be checked with the CSV output function.

\*2 Supports only Thermo-ON/OFF state.

\*3 Alarms can occur when the upper and lower limit values are exceeded due to the AI controller (option).

## 5-2. Basic functions

Sends commands from the building management system to air conditioning equipment. Additionally, sends the air conditioning equipment status to the building management system.

### 5-2-1. Instance number for basic functions

The instance number is configured of the object type + fixed value "1" + group number + member number.

Instance number (6 digits in decimal notation): 0 1 xx xx

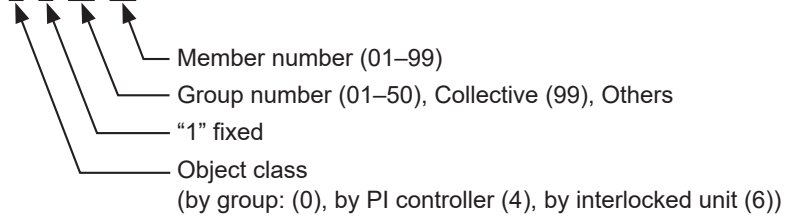

Objects that can be used with the AE-200/AE-50/EW-50 are shown in the table below.

Object	Object type	Instance number	Units					Remarks
			Inactive(0)*23	Active(1)				
			Text-1(1)*23	Text-2(2)	Text-3(3)	Text-4(4)	Text-5(5)	
On Off Setup	BO	01xx01	Stop	Run				*20
On Off State	BI	01xx02	Stop	Run				*20
Alarm Signal	BI	01xx03	Normal	Error				
Error Code	MI	01xx04	01: Normal 02: Other errors 03: Refrigeration system fault 04: Water system error 05: Air system error	06: Electronic system error 07: Sensor fault 08: Communication error 09: System error				
Operational Mode Setup	MO	01xx05	01: Cool 02: Heat 03: Fan	04: Auto 05: Dry 06: Setback				*1 *16 *18 *22
Operational Mode State	MI	01xx06	01: Cool 02: Heat 03: Fan	04: Auto 05: Dry 06: Setback				*1 *3 *16 *18 *22
Fan Speed Setup	MO	01xx07	01: Low 02: High 03: Mid 2	04: Mid 1 05: Auto				*4 *5 *18
Fan Speed State	MI	01xx08	01: Low 02: High 03: Mid 2	04: Mid 1 05 Auto				*4 *5 *18 *21
Room Temp [Water Temp]	AI	01xx09	°F/°C				*16 *25	
Set Temp [Set Water Temp]	AV	01xx10	°F/°C				*16 *25	
Filter Sign [Circulating Water Exchange Sign]	BI	01xx11	OFF	ON				
Filter Sign Reset [Circulating Water Exchange Sign Reset]	BV	01xx12	Reset	Void				
Prohibition On Off	BV	01xx13	Permit	Prohibit				*20
Prohibition Mode	BV	01xx14	Permit	Prohibit				*16
Prohibition Filter Sign Reset [Prohibition Circulating Water Exchange Sign Reset]	BV	01xx15	Permit	Prohibit				

Object	Object type	Instance number	Units					Remarks	
			Inactive(0)*23	Active(1)					
			Text-1(1)*23	Text-2(2)	Text-3(3)	Text-4(4)	Text-5(5)		
Prohibition Set Temperature	BV	01xx16	Permit	Prohibit				*16	
Prohibition Fan Speed	BV	01xx17	Permit	Prohibit					
M-NET Communication State	BI	01xx20	Normal	Error					
System Forced Off	individual	BV	01xx21	Reset	Execute				*10 *11
	collective		019921						
Air Direction Setup	MO	01xx22	Horizontal	Downblow 60%	Downblow 80%	Downblow 100%	Swing	*14 *16 *18	
Air Direction State	MI	01xx23	Horizontal	Downblow 60%	Downblow 80%	Downblow 100%	Swing	*8 *14 *16 *18	
Set Temp Cool	AV	01xx24	°F/°C					*16 *18	
Set Temp Heat	AV	01xx25	°F/°C					*16 *18	
Set Temp Auto	AV	01xx26	°F/°C					*16 *18	
Set High Limit Setback Temp	AV	01xx27	°F/°C					*16 *18 *19	
Set Low Limit Setback Temp	AV	01xx28	°F/°C					*16 *18 *19	
Ventilation Mode Setup	MO	01xx35	Heat Recovery	Bypass	Auto			*15 *18	
Ventilation Mode State	MI	01xx36	Heat Recovery	Bypass	Auto			*15 *18 *21	
Air To Water Mode Setup	MO	01xx37	Heating	Heating ECO	Hot Water	Anti-freeze	Cooling	*15 *16 *17	
Air To Water Mode State	MI	01xx38	Heating	Heating ECO	Hot Water	Anti-freeze	Cooling	*15 *16 *17	
Group Apportioned Electric Energy	AC	01xx39	0.1 [kWh]					*2	
Interlocked Units Apportioned Electric Energy	AC	61aa39	0.1 [kWh]					*2 *7	
Plcontroller Electric Energy 1-4	AC	41mm40-43	0.1 [kWh]					*2 *6 *13 *15 *16 *17 *18	
Pulse Input Electric Energy 1-4	AC	410040-43	0.1 [kWh]					*2 *12 *13 *15 *16 *17 *18	
Group Apportionment Parameter	AC	01xx44	No Units					*2	
Interlocked Units Apportionment Parameter	AC	61aa44	No Units					*2 *7	
Night Purge State	BI	01xx46	OFF	ON				*15 *18	
Thermo On Off State	BI	01xx47	OFF	ON				*16	
System Alarm Signal	BI	010048	Normal	Error					
Error Code Detail	AI	01xx49	No Units						
External Heat Source State	BI	01xx50	OFF	ON					
Plcontroller Alarm Signal	BI	41mm03	Normal	Error				*6	
Trend Log Room Temp	LOG	01xx80						*9 *16 *24 *25	

Object	Object type	Instance number	Units					Remarks
			Inactive(0)*23	Active(1)				
			Text-1(1)*23	Text-2(2)	Text-3(3)	Text-4(4)	Text-5(5)	
Trend Log Group Apportioned Electric Energy	LOG	01xx83						*2 *24
Trend Log Interlocked Units Apportioned Electric Energy	LOG	61aa83						*2 *7 *24
Trend Log Picontroller Electric Energy 1–4	LOG	41mm84–87						*2 *6 *13 *15 *16 *17 *18 *24
Trend Log Pulse Input Electric Energy 1–4	LOG	410084–87						*2 *13 *15 *16 *17 *18 *24
Trend Log Group Apportionment Parameter	LOG	01xx88						*2 *24
Trend Log Interlocked Units Apportionment Parameter	LOG	61aa88						*2 *7 *24

\*1 “Dry” can be used only when the “Use Dry Mode” setting is enabled (checked) on the BACnet® Setting Tool. (The default setting is disabled (unchecked).)

\*2 “Charge” license is required for AE-200/AE-50/EW-50.

\*3 When the “Operational Mode State” received from the indoor unit is “Auto Cool”, “Cool” can be selected; when it is “Auto Heat”, “Heat” can be selected, or “Auto” can be selected for both.

\*4 “Use Fan Speed Mid1/Mid2” setting of the BACnet® Setting Tool, and effective fan speeds from indoor unit, LOSSNAY, and OA Processing Unit fan speed switching steps are shown in the table below. (The default setting of “Use Fan Speed Mid1/Mid2” of the BACnet® Setting Tool is disabled (unchecked).)  
(In the automatic wind velocity compatible model, “Auto” is valid in addition to the fan speed in this table.)

V: Available

Unit type	“Use Fan Speed Mid1/Mid2” setting	Number of available fan speeds	Available fan speed			
			Low	Mid 2	Mid 1	High
Indoor unit	Enabled	2		V		V
		3		V	V	V
		4	V	V	V	V
	Disabled	2–4	V			V
LOSSNAY and OA Processing Unit	Enabled	1				V
		2	V			V
		3	V	V		V
		4	V	V	V	V
	Disabled	1				V
		2–4	V			V

\*5 Low < Mid 2 < Mid 1 < High

\*6 mm: PI controller address (01–50)

\*7 Can be used only for the interlocked units.  
aa: Interlocked unit address (01–50)

\*8 When the air direction received from the indoor unit is “Downblow 20%” or “Auto”, “Horizontal” will be output to BACnet®.

\*9 The value of the “Present\_Value” in the “Room Temp” (AI\_01xx09) object is logged in as the log record.

\*10 Batch commands are made for the “System Forced Off” instance number (019921) for all groups.

\*11 When the “System Forced Off” (individual/collective) from BACnet® communication is used, do not set the “External Input Setting” for AE-200/AE-50/EW-50 to “ON/OFF (Level signal)”. “External Input Setting” can be configured on the Initial Setting Tool, Web Browser for Initial Settings, or AE-200/AE-50’s LCD. (Refer to the AE-200/AE-50/EW-50 Instruction Book (Initial Settings) for settings methods.)

\*12 Electric energy for the electricity meter connected to the Pulse Input (PI) of AE-50/EW-50

\*13 Electric energy 1 to 4 correspond to signal lines Ch1 to 4 on the PI controller or metering devices 1 to 4 connected to Pulse Input (PI) of AE-50/EW-50.

\*14 It may differ from the actual air direction depending on the type of indoor unit (Ceiling-concealed Ducted, Wall-mounted, Floor-standing). An example of a Floor standing PFFY-P VKM-E is as follows.

	Setting/Status				
Air direction on the BACnet®	Horizontal	Downblow 60%	Downblow 80%	Downblow 100%	Swing
Actual air direction	Upblow 100%	Upblow 80%	Upblow 60%	Horizontal	Swing

- \*15 Cannot be used with an indoor unit model.  
Differences in supported/not supported objects depending on whether it is an indoor unit, LOSSNAY or the Air To Water model are indicated on the following page.
- \*16 Cannot be used with a LOSSNAY which is not interlocked with an indoor unit.  
Differences in supported/not supported objects depending on whether it is an indoor unit, LOSSNAY or the Air To Water model are indicated on the following page.
- \*17 Cannot be used with an OA Processing Unit which is not interlocked with an indoor unit.  
Differences in supported/not supported objects depending on whether it is an indoor unit, LOSSNAY or the Air To Water model are indicated on the following page.
- \*18 Cannot be used with an Air To Water model.  
Differences in supported/not supported objects depending on whether it is an indoor unit, LOSSNAY or the Air To Water model are indicated on the following page.
- \*19 It can only be used if the system controller is AE-200/AE-50A/EW-50A and the indoor unit is a Setback mode supported model.
- \*20 Do not use this when "External Input Setting" for AE-200/AE-50/EW-50 is set to "ON/OFF (Level signal)". "External Input Setting" can be configured on the Initial Setting Tool or AE-200/AE-50's LCD. (Refer to the AE-200/AE-50/EW-50 Instruction Book (Initial Settings) for settings methods.)
- \*21 During Night Purge state, this operates using a specific fan speed and ventilation mode, but these are not reflected in the status display. As a result, the read status from BACnet® communications may differ from actual fan speeds and ventilation modes. Additionally, carrying out fan speed and ventilation mode settings during Night Purge state will not change actual operation, and these will only be reflected in the status display.
- \*22 "Setback" is available only when the "Old model compatibility mode" is set to "OFF" on the Initial Setting Tool or AE-200/AE-50's LCD.
- \*23 "Inactive(0),Active(1)" is applied when the object type is BO/BI/BV, and "Text-1(1),Text-2(2),..." is applied when the object type is MO/MI.
- \*24 Use the BACnet® Trial Run Tool to check or set the "Log\_Interval" property. (Refer to the AE-200/AE-50/EW-50 Instruction Book (BACnet® Trial Run Tool) for settings methods.)
- \*25 When E-OA model unit is connected, outlet air measurement temperature is used for "Room Temp/Trend Log Room Temp," and outlet air preset temperature is used for "Set Temp."

Whether or not the object can be supported by the unit type is indicated in the following table.  
The AE-200/AE-50/EW-50 only creates objects supported by each group.

V: Supported  
—: Not supported

Object	Object type	Instance number	Unit type			Remarks
			Indoor unit and OA Processing Unit that is not interlocked with indoor units	LOSSNAY unit that is not interlocked with indoor units	Air To Water	
On Off Setup	BO	01xx01	V	V	V	*5
On Off State	BI	01xx02	V	V	V	
Alarm Signal	BI	01xx03	V	V	V	
Error Code	MI	01xx04	V	V	V	
Operational Mode Setup	MO	01xx05	V	—	—	
Operational Mode State	MI	01xx06	V	—	—	
Fan Speed Setup	MO	01xx07	V	V	—	
Fan Speed State	MI	01xx08	V	V	—	
Room Temp [Water Temp]	AI	01xx09	V	—	V	*8
Set Temp [Set Water Temp]	AV	01xx10	V	—	V	*2
Filter Sign [Circulating Water Exchange Sign]	BI	01xx11	V	V	V	
Filter Sign Reset [Circulating Water Exchange Sign Reset]	BV	01xx12	V	V	V	
Prohibition On Off	BV	01xx13	V	V	V	*5
Prohibition Mode	BV	01xx14	V	—	V	
Prohibition Filter Sign Reset [Prohibition Circulating Water Exchange Sign Reset]	BV	01xx15	V	V	V	
Prohibition Set Temperature	BV	01xx16	V	—	V	
Prohibition Fan Speed	BV	01xx17	V	—	—	*1 *6
M-NET Communication State	BI	01xx20	V	V	V	
System Forced Off	individual	BV	01xx21	V	V	
	collective		019921			
Air Direction Setup	MO	01xx22	V	—	—	*1
Air Direction State	MI	01xx23	V	—	—	*1
Set Temp Cool	AV	01xx24	V	—	—	*2
Set Temp Heat	AV	01xx25	V	—	—	*2
Set Temp Auto	AV	01xx26	V	—	—	*2
Set High Limit Setback Temp	AV	01xx27	V	—	—	
Set Low Limit Setback Temp	AV	01xx28	V	—	—	
Ventilation Mode Setup	MO	01xx35	V	V	—	*3
Ventilation Mode State	MI	01xx36	V	V	—	*3
Air To Water Mode Setup	MO	01xx37	—	—	V	
Air To Water Mode State	MI	01xx38	—	—	V	
Group Apportioned Electric Energy	AC	01xx39	V	V	V	
Interlocked Units Apportioned Electric Energy	AC	61aa39	—	—	—	*4

Object	Object type	Instance number	Unit type			Remarks
			Indoor unit and OA Processing Unit that is not interlocked with indoor units	LOSSNAY unit that is not interlocked with indoor units	Air To Water	
Picontroller Electric Energy 1-4	AC	41mm40-43	—	—	—	
Pulse Input Electric Energy 1-4	AC	410040-43	—	—	—	
Group Apportionment Parameter	AC	01xx44	V	—	V	
Interlocked Units Apportionment Parameter	AC	61aa44	—	—	—	*4
Night Purge State	BI	01xx46	V	V	—	*3
Thermo On Off State	BI	01xx47	V	—	V	
Error Code Detail	AI	01xx49	V	V	V	
External Heat Source State	BI	01xx50	V	—	—	*7
Picontroller Alarm Signal	BI	41mm03	—	—	—	
Trend Log Room Temp	LOG	01xx80	V	—	V	
Trend Log Group Apportioned Electric Energy	LOG	01xx83	V	V	V	
Trend Log Interlocked Units Apportioned Electric Energy	LOG	61aa83	—	—	—	*4
Trend Log Picontroller Electric Energy 1-4	LOG	41mm84-87	—	—	—	
Trend Log Pulse Input Electric Energy 1-4	LOG	410084-87	—	—	—	
Trend Log Group Apportionment Parameter	LOG	01xx88	V	—	V	
Trend Log Interlocked Units Apportionment Parameter	LOG	61aa88	—	—	—	*4

\*1 An OA Processing Unit which is not interlocked with an indoor unit is not supported.

\*2 An example of the temperature setting range for the indoor unit/Air To Water is shown in the following table. (Indicates the setting temperature range of a typical model. May differ depending on the model).

Indoor unit

Operational mode		Cool	Heat	Auto	Dry
Standard model	Auto (Single-set-point) mode	19-30°C	17-28°C	19-28°C	19-30°C
	Auto (Dual-set-points) mode	19-35°C	4.5-28°C	Cool: 19-35°C Heat: 4.5-28°C	19-35°C
E-OA model		10-24.5°C	17-35°C	17-24.5°C	10-24.5°C

Air To Water

Operational mode	Heating	Heating ECO	Hot Water	Anti-freeze	Cooling
Booster unit (BU)	30-50°C	30-45°C	30-70°C	10-45°C	Invalid
HEX unit (AU)	30-45°C	30-45°C	Invalid	10-45°C	10-30°C

(Conversion for communication of the air conditioning equipment and BACnet® is carried out within a range of 0 to 99°C.)

\*3 Supported only by LOSSNAY and OA Processing Unit that are not interlocked with indoor units.

\*4 Supported by OA Processing Unit that is interlocked with indoor units.

\*5 Do not use this when "External Input Setting" for AE-200/AE-50/EW-50 is set to "ON/OFF (Level signal)". "External Input Setting" can be configured on the Initial Setting Tool or AE-200/AE-50's LCD. (Refer to the AE-200/AE-50/EW-50 Instruction Book (Initial Settings) for settings methods.)

\*6 Can be used when the indoor unit supports "Prohibition Fan Speed".

\*7 Can be used on the unit models produced in April 2012 or later.

\*8 When E-OA model unit is connected, outlet air measurement temperature is used.



### 5-3. Set temperature objects

Select the set temperature objects below according to the indoor unit group configuration in a given air conditioning system.

V: Selectable  
—: Not selectable

Object	Object type	Instance number	Models that support the Auto (Dual-set-points) mode *3			Models that do not support the Auto (Dual-set-points) mode *3
			Auto (Single-set-point) mode *1	Auto (Dual-set-points) mode *1	Old model compatibility mode *2	
Set Temp	AV	01xx10	—	—	V	V
Set Temp Cool	AV	01xx24	V	V	—	—
Set Temp Heat	AV	01xx25	V	V	—	—
Set Temp Auto	AV	01xx26	V	—	—	—
Set High Limit Setback Temp	AV	01xx27	V*4	V*4	—	—
Set Low Limit Setback Temp	AV	01xx28	V*4	V*4	—	—

- \*1 Auto (Single-set-point) mode or Auto (Dual-set-points) mode can be set on the local remote controller for each indoor unit. Refer to the indoor unit Instruction Book for details about these modes.
- \*2 Old model compatibility mode can be collectively set for the M-NET system on the Initial Setting Tool or AE-200/AE-50's LCD. (Refer to the AE-200/AE-50/EW-50 Instruction Book (Initial Settings) for settings methods.)
- \*3 Selectable/Not selectable of Auto (Dual-set-points) mode is determined automatically for each group. (Group is treated as Auto (Dual-set-points) mode selectable only if all indoor units, all remote controllers, and all system controllers are Auto (Dual-set-points) mode selectable.)
- \*4 It can only be used if the system controller is AE-200A/AE-50A/EW-50A and the indoor unit is a Setback mode supported model.
- \*5 When E-OA model unit is connected, outlet air preset temperature is used.

#### (1) When the building management system supports two temperature setting (for cooling and heating individually)

Use temperature setting object for “Set Temp” (AV\_01xx10) in a group which includes an Auto (Dual-set-points) mode unsupported model.

When operating an Auto (Single-set-point) mode indoor unit in the operation mode “Auto”, use the temperature setting object for “Set Temp Auto” (AV\_01xx26).

When operating an Auto (Dual-set-points) mode indoor unit in the operation mode “Auto”, use the temperature setting object for “Set Temp Cool” (AV\_01xx24) and “Set Temp Heat” (AV\_01xx25).

#### (2) When the building management system supports only one temperature setting (common for cooling and heating)

Set the “Old model compatibility mode” setting to “ON” on the Initial Setting Tool or AE-200/AE-50's LCD. Use the temperature setting object for “Set Temp” (AV\_01xx10).

### 5-4. “System Forced Off” forced-reset function

“System Forced Off (individual/collective)” can be forcibly reset from the BACnet® Setting Tool when it cannot be reset from the building management system due to a problem such as a communication error.

#### 5-4-1. “System Forced Off” forced-reset function specifications

When forced-reset of “System Forced Off” is performed, the unit status will be as follows.

Unit	Status
AE-200/AE-50/EW-50	“System Forced Off (individual/collective)” will all be set to “Reset (Inactive)”.
Air conditioning unit	Return the prohibition of remote controller operation (ON/OFF) to the state before “System Forced Off” occurs.

## 5-5. Apportioned electricity billing function

The AE-200/AE-50/EW-50 apportioned electricity billing function calculates the “electric energy for the electricity meter” and the “apportioned electric energy for the electricity meter per group/interlocked unit” or the “apportionment parameters for apportioning the electric energy per group/interlocked unit,” and stores this in the accumulator. Additionally, the accumulator is stored in “Log\_Buffer” of the trend log.

The cumulative value and trend log data can be read by BACnet<sup>®</sup> communication.

BACnet<sup>®</sup> communications cannot read billing information.

When using the apportioned electricity billing function, a “Charge” license is required for each AE-200/AE-50/EW-50. Refer to the AE-200/AE-50/EW-50 Instruction Book (Apportioned Electricity Billing Function) for details on the apportioned electricity billing function.

When using the apportioned electricity billing function, refer to (3) “When using an apportioned electricity billing function” in section 3-1 “Sample system configurations” for system configuration.

### 5-5-1. Apportioned electricity billing function specifications

The apportioned electricity billing function in the BACnet<sup>®</sup> function is configured of an accumulator object which stores the electric energy and other cumulative value/apportioned results cumulative value and the trend log object which reads the accumulator for each fixed time and accumulates the value. When using the apportioned electricity billing function, a “Charge” license is required.

**Note**

An interlocked unit is an OA Processing Unit (FU attribute) linked to an indoor unit, and covers those affiliated OA Processing Units that can be registered in the energy management block settings of the Initial Setting Tool.

This does not refer to an OA Processing Unit (IC attribute) that is not linked to an indoor unit that can have group settings performed through the centralized controller.

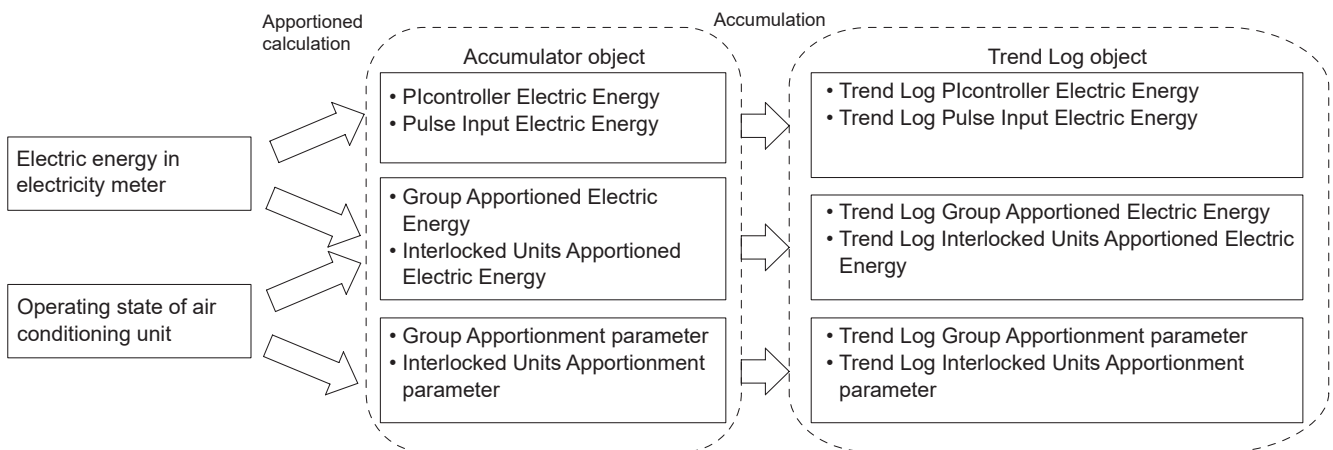

#### Accumulator specifications

Data type	Apportioning type	Contents *3
Electric energy *1 *4	Apportionment source	Cumulative electric energy from electricity meter read from PI controller
		Cumulative electric energy from electricity meter read from built-in Pulse Input (PI) of AE-50/EW-50
	Apportioned results	Electric energy for each group (indoor unit + outdoor unit) *5
		Electric energy for each interlocked unit (indoor unit + outdoor unit) *5
Apportionment parameter *2 *4 *6	Apportionment parameter	Apportionment parameters for each group (for outdoor units) *5
		Apportionment parameters for each interlocked unit (for outdoor units) *5

\*1 Electricity meter must be connected to obtain the electric energy. Also, apportionment calculation is carried out using AE-200 for dedicated electricity apportionment.

\*2 The electricity meter need not be connected to obtain the apportionment parameters. Select when carrying out apportionment calculations in a building management system.

\*3 Cumulative data for 30 minute cycles. (Data for until XX:00 and XX:30 minutes is updated at XX:15 and XX:45 respectively)

\*4 The value can be compensated by writing the value in the “Value\_Set” of the accumulator object.

\*5 Stores apportionment results by the apportionment method set in the billing function settings for the apportioned electricity billing function.

\*6 The apportionment parameter is a value that is proportionate to the electric energy consumption calculated based on the operation status and operation time of each air conditioning unit, and will be the reference value for separately-calculating the electric energy (or electricity charge) using the ratio of this value and the total value of apportionment parameters for all units.

Trend log specifications (only for portions related to the apportioned electricity billing function)

Item	Setting contents	Setting method
Collection cycle	30 minutes to 1440 minutes (1 day) Can be set in 30-minute increments. ("Log_Interval" property) Initial value: 30 minutes	Settings on the building management system
Collection period	4 days*1 to 192 days*2 (retain the value for the most recent 192 items)	
Collection timing	Carry out collection for each collection cycle using 1970/1/1 00:00:00 as a starting point.	
Collection starts	After participation sequence completed (Status = Operational)	
Log deleted	When "0" is written to the "Record_Count" property	

\*1 When the collection cycle is 30 minutes

\*2 When the collection cycle is 1 day

**5-5-2. Accumulator object**

The instance number of the accumulator object which stores the cumulative value is as follows.

Object	Object type	Instance number	Apportioning type	Metering device	Contents
Group Apportioned Electric Energy	AC	01xx39	Apportioned results	Required	Stores the cumulative value of the electric energy (indoor unit + outdoor unit) for each group.
Interlocked Units Apportioned Electric Energy	AC	61aa39			Stores the cumulative value of the electric energy (indoor unit + outdoor unit) for each interlocked unit (OA Processing Unit).
PIcontroller Electric Energy 1-4	AC	41mm40-43	Apportionment source data		Cumulative value (for 4 channels) of electric energy accumulated in PI controller
Pulse Input Electric Energy 1-4	AC	410040-43			Cumulative value (for 4 channels) of electric energy accumulated in a built-in Pulse Input (PI) of AE-50/EW-50
Group Apportionment Parameter	AC	01xx44	Apportionment parameter	Not required	Stores electric energy apportionment parameters (for outdoor units) for each group.
Interlocked Units Apportionment Parameter	AC	61aa44			Stores electric energy apportionment parameters (for outdoor units) for each interlocked unit (OA Processing Unit).

\* xx: Group number (01-50)

\* mm: PI controller address (01-50)

\* aa: Interlocked unit address (01-50)

### 5-5-3. Trend log object

Instance number of the trend log object (only the portion related to the apportioned electricity billing function) which stores the accumulator log is as follows.

Object	Object type	Instance number	Apportioning type	Metering device	Contents
Trend Log Group Apportioned Electric Energy	LOG	01xx83	Apportioned results	Required	Accumulates "Present_Value" of accumulator (Group Apportioned Electric Energy) for each collection cycle.
Trend Log Interlocked Units Apportioned Electric Energy	LOG	61aa83			Accumulates "Present_Value" of accumulator (Interlocked Units Apportioned Electric Energy) for each collection cycle.
Trend Log PIcontroller Electric Energy 1-4	LOG	41mm84-87	Apportionment source data		Accumulates "Present_Value" of accumulator (PIcontroller Electric Energy 1-4) for each collection cycle.
Trend Log Pulse Input Electric Energy 1-4	LOG	410084-87			Accumulates "Present_Value" of accumulator (Pulse Input Electric Energy 1-4) for each collection cycle.
Trend Log Group Apportionment parameter	LOG	01xx88	Apportionment parameter	Not required	Accumulates "Present_Value" of accumulator (Group Apportionment parameter) for each collection cycle.
Trend Log Interlocked Units Apportionment Parameter	LOG	61aa88			Accumulates "Present_Value" of accumulator (Interlocked Units Apportionment Parameter) for each collection cycle.

\* xx: Group number (01-50)

\* mm: PI controller address (01-50)

\* aa: Interlocked unit address (01-50)

#### Note

If the apportioned electricity billing function is enabled and the power to the AE-200/AE-50/EW-50 is turned on between 10 and 15, or between 40 and 45 minutes every hour, then when accumulator objects and trend log objects are first collected, the object "Reliability" property may be other than "0" (indicating no reliability).

### 5-5-4. System restrictions for apportioned electricity billing function

- "Charge" license is required for each AE-200/AE-50/EW-50.
- Combinations of AE-200 and AE-50/EW-50 units are required.
- M-NET of AE-200 for billing function cannot be used.
- Built-in Pulse Input (PI) of AE-200 for billing function cannot be used.
- Electric energy measurement using a PI controller is recommended.  
(If AE-50/EW-50 with built-in Pulse Input (PI) is used, pulse input will not be possible when the AE-50/EW-50 is stopped, during power outages or during software updates. This could result in discrepancies between the measurements and the actual electric energy consumed.)
- Ensure that the same software versions are used on AE-200/AE-50/EW-50 units.
- The apportioned electricity billing function (AE-200 Apportion) and apportioned electricity billing function (TG-2000A Apportion) cannot be used together.
- When the apportioned electricity billing function (AE-200 Apportion) is being used and you intend to use the TG-2000A integration software, check that the TG-2000A version is 6.60 or later.
- An electricity meter is required for each AE-200 and for each AE-200 system comprising expansion controller AE-50/EW-50. You cannot make settings (apportionment settings) that span multiple AE-200 systems.

## 5-5-5. Notes on using the apportioned electricity billing function

- This function is our original electric energy apportionment system that apportions electric energy using input from electricity meters with a pulse generator function. Rather than directly measuring the electric energy consumed by each air conditioner, pulses are input based on the air conditioner usage by determining the air conditioner operating status from the content of its communication with the indoor and outdoor units.

### To all users (user license agreement)

**The information provided here constitutes an agreement between Mitsubishi Electric and the customer.**

**If this “apportioned electricity billing function for the AE-200 air conditioning control system” is used, this agreement assumes that the customer is using the aforementioned system having agreed to the terms listed below.**

- **Mitsubishi Electric and its sales companies accept no liability whatsoever for any incidental, consequential or special damages incurred by the customer, even where the sales company has received notification of the potential for damages of that kind.**

**Nor is any liability accepted for any allegations regarding the rights of a third party.**

#### **Important**

**Any individual agreement between the building owner and a tenant regarding the use of this product should incorporate the parties’ agreement to or accord with the fact that “charges for the use of air conditioning will be collected in the form of apportioned totals based on the operating status of air conditioners (including temporary measures to deal with faults)”.**

- **This is a system for estimating the operating electric energy consumed for air conditioning. As such it cannot be used as a proof of transaction.**  
**Also, amounts metered using electricity meters are also counted using pulse conversion and cannot be used as a proof of transaction.**
- This is not a system (or its equivalent) in which the operating electric energy consumed by each air conditioner is directly measured at the location where the electricity is supplied.
- Because this is an apportionment method that uses the operating status of air conditioner indoor units, even where the operating time for indoor units is the same, the amount of operating electric energy consumed may differ depending on the model configuration and operating status of the outdoor units. (The apportioned electric energy may be different when compared with a situation where an electricity meter is assigned to each air conditioner.)
- Air conditioners still receive current even when stopped, and electric energy is apportioned to idle air conditioners as standby electric energy.
- **While the amounts of electric energy, water and gas consumed are obtained through pulse conversion, factors such as performance and accuracy are dependent on the metering devices and Mitsubishi Electric is in no way responsible for such factors.**
- If electric power to the AE-200/AE-50/EW-50 and PI controller is interrupted due to a power outage but the air conditioner is still running, electric energy cannot be apportioned correctly.
- Because the unit price digits for each tenant (energy management block) are rounded off in the charge calculation process, the figures may differ from the total electric energy charges.
- Adjust the time in the following method as there are discrepancies in the results of apportionment processing when there is a time lag.  
When there is no connection to BACnet® or when time synchronization is not carried out from the building management system, perform periodic time adjustment on the AE-200’s LCD. (Even if time is adjusted with AE-50/EW-50, it is overwritten with the time of AE-200.)  
To perform date and time synchronization from the building management system with connection to BACnet®, set the “Time Master/Sub” setting to “Sub” on the AE-200 for billing function. The “Time Master/Sub” setting can be made on the Initial Setting Tool or AE-200/AE-50’s LCD. (Refer to the AE-200/AE-50/EW-50 Instruction Book (Initial Settings) for settings methods.)
- Mitsubishi Electric accepts no liability for the incorrect apportionment of electric energy due to problems such as power outages or equipment faults.

## 5-6. Alarm Signal

Error status of the AE-200/AE-50/EW-50 and of air conditioning units connected to the AE-200/AE-50/EW-50 can be read from the building management system.

Error causes and corresponding alarm objects are shown below.

V: Supported

Error cause		Supported object					
		Alarm Signal (BI_01xx03)	Error Code (MI_01xx04)	Error Code Detail (AI_01xx49)	M-NET Communication State (BI_01xx20)	System Alarm Signal (BI_010048)	Plcontroller Alarm Signal (BI_41mm03)
Equipment error	AE-200/AE-50/EW-50 error					V	
	Air conditioning unit error	V	V	V			
	PI controller error						
	ME remote controller or system controller error						
M-NET communication error	AE-200/AE-50/EW-50 communication error, M-NET address overlap (Error code: 6600–6603)	V *1	V	V	V	V	V
	Communication error with air conditioning unit (Error code: 6606–6608)	V *1	V	V	V		
	Communication error with PI controller (Error code: 6606–6608)						V *2
	Communication error with ME remote controller or system controller (Error code: 6606–6608)						
LAN communication error	LAN1 communication error of AE-200/AE-50/ EW-50 (Communication error between AE-200 and expansion controller)					V	
	LAN2 (BACnet®) communication error of AE-200/AE-50/EW-50						

\* xx: Group number (01–50)

\* mm: PI controller address (01–50)

\*1 Only when “Not reflect communication error to alarm signal” setting on the BACnet® Setting Tool is unchecked

\*2 The PI controller is not subject to group settings, therefore this is not included in the Alarm Signal (BI\_01xx03).

## 5-7. Event service specifications

The table below shows the supported notifications for each object.  
Notification settings can be made on the BACnet® Setting Tool.

### 5-7-1. Event service of objects

The availability of the notification setting in BACnet® Setting Tool for each object is shown in the following table.

V: Notification can be set on the BACnet® Setting Tool.  
—: Notification cannot be set.

Object	Object ID	Event Notification	COV Notification	Remarks
On Off Setup	BO_01xx01	V	V	*4
On Off State	BI_01xx02	V	V	
Alarm Signal	BI_01xx03	V *1	V	
Error Code	MI_01xx04	—	V	
Operational Mode Setup	MO_01xx05	—	V	
Operational Mode State	MI_01xx06	—	V	
Fan Speed Setup	MO_01xx07	—	V	
Fan Speed State	MI_01xx08	—	V	
Room Temp [Water Temp]	AI_01xx09	V	V	
Set Temp [Set Water Temp]	AV_01xx10	—	V	
Filter Sign [Circulating Water Exchange Sign]	BI_01xx11	V	V	
Filter Sign Reset [Circulating Water Exchange Sign Reset]	BV_01xx12	—	V	
Prohibition On Off	BV_01xx13	—	V	*4
Prohibition Mode	BV_01xx14	—	V	
Prohibition Filter Sign Reset [Prohibition Circulating Water Exchange Sign Reset]	BV_01xx15	—	V	
Prohibition Set Temperature	BV_01xx16	—	V	
Prohibition Fan Speed	BV_01xx17	—	V	
M-NET Communication State	BI_01xx20	V	V	
System Forced Off	individual	—	V	
	collective			
Air Direction Setup	MO_01xx22	—	V	
Air Direction State	MI_01xx23	—	V	
Set Temp Cool	AV_01xx24	—	V	
Set Temp Heat	AV_01xx25	—	V	
Set Temp Auto	AV_01xx26	—	V	
Set High Limit Setback Temp	AV_01xx27	—	V	
Set Low Limit Setback Temp	AV_01xx28	—	V	
Ventilation Mode Setup	MO_01xx35	—	V	
Ventilation Mode State	MI_01xx36	—	V	
Air To Water Mode Setup	MO_01xx37	—	V	
Air To Water Mode State	MI_01xx38	—	V	
Group Apportioned Electric Energy	AC_01xx39	V	—	
Interlocked Units Apportioned Electric Energy	AC_61aa39	V	—	
Plcontroller Electric Energy 1–4	AC_41mm40–43	V	—	
Pulse Input Electric Energy 1–4	AC_410040–43	V	—	
Group Apportionment Parameter	AC_01xx44	V	—	



Object	Object ID	Event Notification	COV Notification	Remarks
Interlocked Units Apportionment Parameter	AC_61aa44	V	—	
Night Purge State	BI_01xx46	V	V	
Thermo On Off State	BI_01xx47	V	V	
System Alarm Signal	BI_010048	V *2	V	
Error Code Detail	AI_01xx49	—	V	
External Heat Source State	BI_01xx50	V	V	
PIcontroller Alarm Signal	BI_41mm03	V *3	V	
Trend Log Room Temp	LOG_01xx80	—	—	
Trend Log Group Apportioned Electric Energy	LOG_01xx83	—	—	
Trend Log Interlocked Units Apportioned Electric Energy	LOG_61aa83	—	—	
Trend Log PIcontroller Electric Energy 1–4	LOG_41mm84–87	—	—	
Trend Log Pulse Input Electric Energy 1–4	LOG_410084–87	—	—	
Trend Log Group Apportionment Parameter	LOG_01xx88	—	—	
Trend Log Interlocked Units Apportionment Parameter	LOG_61aa88	—	—	
Notification Class	CLS_xxxxxx	—	—	xxxxxx: Notification class ID
Device	DEV_xxxxxx	—	—	xxxxxx: Device No.

\* xx: Group number (01–50)

\* mm: PI controller address (01–50)

\* aa: Interlocked unit address (01–50)

\*1 Air conditioning unit error code (4 digits) will be output to “MessageText”.

\*2 Error code (4 digits) will be output to “MessageText”.

\*3 PI controller error code (4 digits) will be output to “MessageText”.

\*4 Do not use this when “External Input Setting” for AE-200/AE-50/EW-50 is set to “ON/OFF (Level signal)”. “External Input Setting” can be configured on the Initial Setting Tool or AE-200/AE-50’s LCD. (Refer to the AE-200/AE-50/EW-50 Instruction Book (Initial Settings) for settings methods.)



## 5-8. BACnet® information and storage timing/cycle in nonvolatile memory within the AE-200/AE-50/EW-50

The following BACnet® information (object property value) is stored in nonvolatile memory inside AE-200/AE-50/EW-50 for each storage timing or cycle in the table below.

After the property value has been updated, if the power source for AE-200/AE-50/EW-50 is cut within the storage cycle and when restart is carried out, it may return to the property value before updating.

Object	Object ID	Property	Storage timing or cycle
On Off State Thermo On Off State External Heat Source State	BI_01xx02 BI_01xx47 BI_01xx50	Present_Value	60 minutes *1
Room Temp	AI_01xx09	High_Limit	When updated *3
		Low_Limit	When updated *3
		Deadband	When updated *3
		Limit_Enable	When updated *3
Group Apportioned Electric Energy Interlocked Units Apportioned Electric Energy Picontroller Electric Energy 1-4 Pulse Input Electric Energy 1-4 Group Apportionment Parameter Interlocked Units Apportionment Parameter	AC_01xx39 AC_61aa39 AC_41mm40-43 AC_410040-43 AC_01xx44 AC_61aa44	Present_Value	30 minutes *2
		Value_Change_Time	When updated *3
		Value_Before_Change	When updated *3
		Value_Set	When updated *3
		Pulse_Rate	30 minutes *2
		High_Limit	When updated *3
		Low_Limit	When updated *3
		Limit_Enable	When updated *3
		Trend Log Room Temp	LOG_01xx80
Start_Time	When updated *3		
Stop_Time	When updated *3		
Log_Interval	When updated *3		
Trend Log Group Apportioned Electric Energy Trend Log Interlocked Units Apportioned Electric Energy Trend Log Picontroller Electric Energy 1-4 Trend Log Pulse Input Electric Energy 1-4 Trend Log Group Apportionment Parameter Trend Log Interlocked Units Apportionment Parameter	LOG_01xx83 LOG_61aa83 LOG_41mm84-87 LOG_410084-87 LOG_01xx88 LOG_61aa88	Enable	When updated *3
		Start_Time	When updated *3
		Stop_Time	When updated *3
		Log_Interval	When updated *3
		Record_Count	When updated *3
		Total_Record_Count	When updated *3
		Log_Buffer	When updated *3
Device	DEV_xxxxxx	Active_COV_Subscriptions	When updated *3
Notification Class	CLS_xxxxxx	Recipient_List	When updated *3

\*1 At XX:05 minutes every hour

\*2 At XX:15 minutes and XX:45 minutes every hour

\*3 Will be saved within 1 minute after the property value is updated.

# 6. Usage (AE-200/AE-50/EW-50 BACnet® connection mode)

## 6-1. AE-200/AE-50/EW-50 BACnet® connection mode

The AE-200/AE-50/EW-50 BACnet® function operates in the following two connection modes.

Mode name	Details
“ONLINE” mode	This is a mode while operating which carries out BACnet® communication.
“OFFLINE” mode	This is a mode while maintenance and settings in which BACnet® communication does not occur.

Transition of “ONLINE” and “OFFLINE” mode is as follows.

The current mode can be checked using the BACnet® Setting Tool.

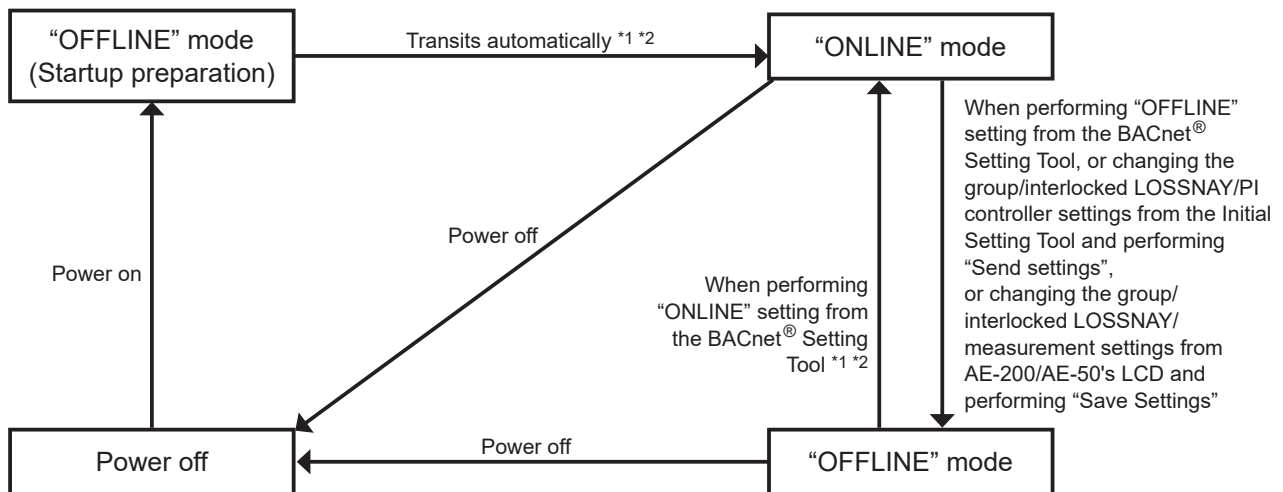

\*1 Does not switch to the “ONLINE” mode in the following cases:

- When a valid “BACnet connection” license is not registered
- When inconsistency occurs in BACnet® settings information, or before reflecting the first BACnet® settings
- When the metering device is registered in the AE-200/AE-50/EW-50 “Measurement” settings or “PI Controller” settings, and the corresponding BACnet® accumulator object (PIcontroller Electric Energy 1–4, Pulse Input Electric Energy 1–4) is not enabled (Even if the target accumulator object is not required, enable it. “Measurement” settings can be configured on the AE-200/AE-50’s LCD, and “PI Controller” settings can be configured on the Initial Setting Tool. Refer to the AE-200/AE-50/EW-50 Instruction Book (Initial Settings) for settings methods.)

\*2 When there are many setting groups, the time to migration to “ONLINE” mode gets longer. (maximum of approximately 10 minutes)

# 7. Checking installation operations and performing trial run

For air conditioning system designs before initial settings, consult your dealer.

## 7-1. Flow of initial settings

In general, the initial settings are largely divided into 4 steps as follows.

By making initial settings along these 4 steps, the cause classification in case of trouble is clarified in each step and the initial settings can be advanced efficiently.

Make the initial settings according to the following procedures.

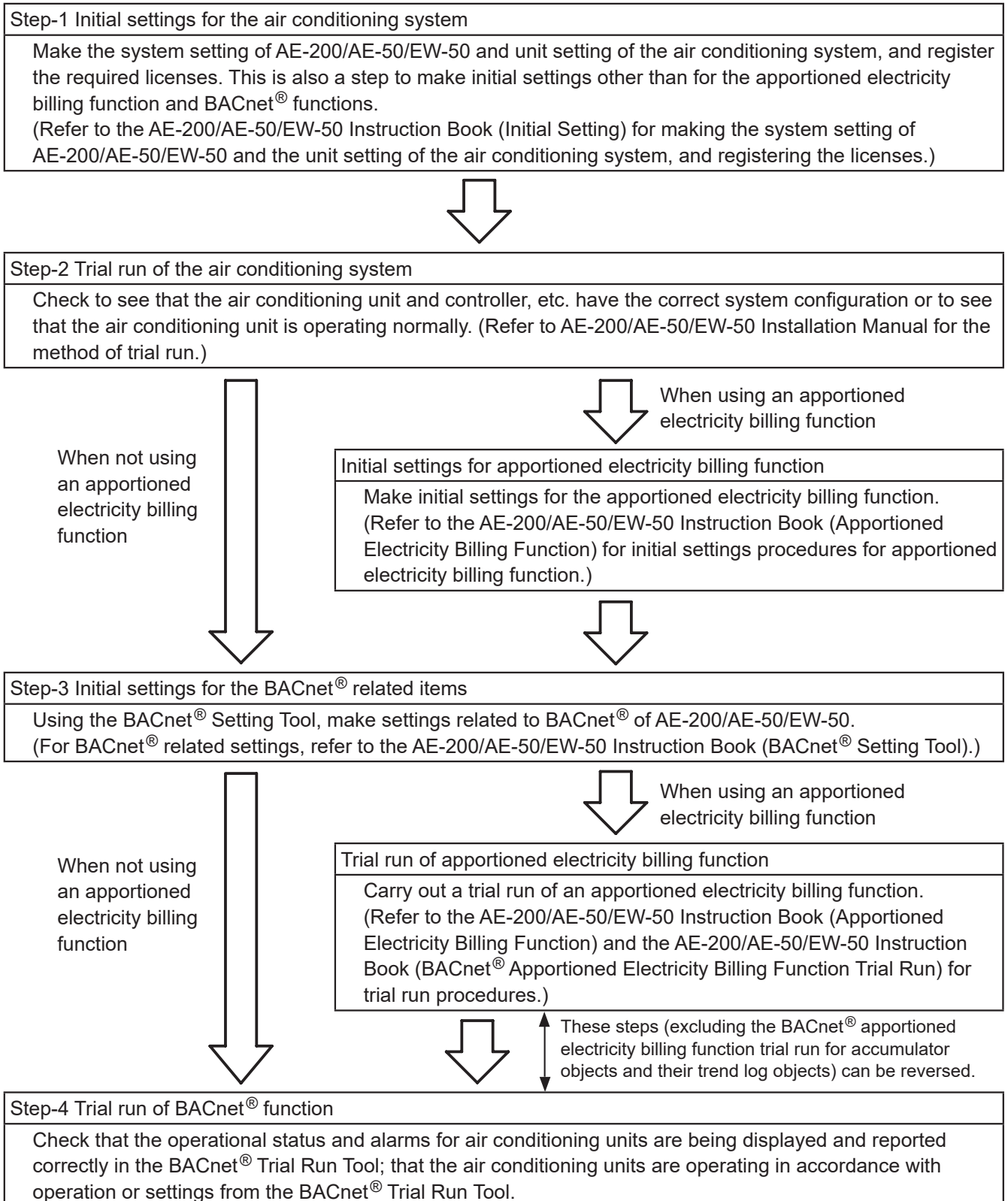

Connection image after completion of initial settings and work scope of each step

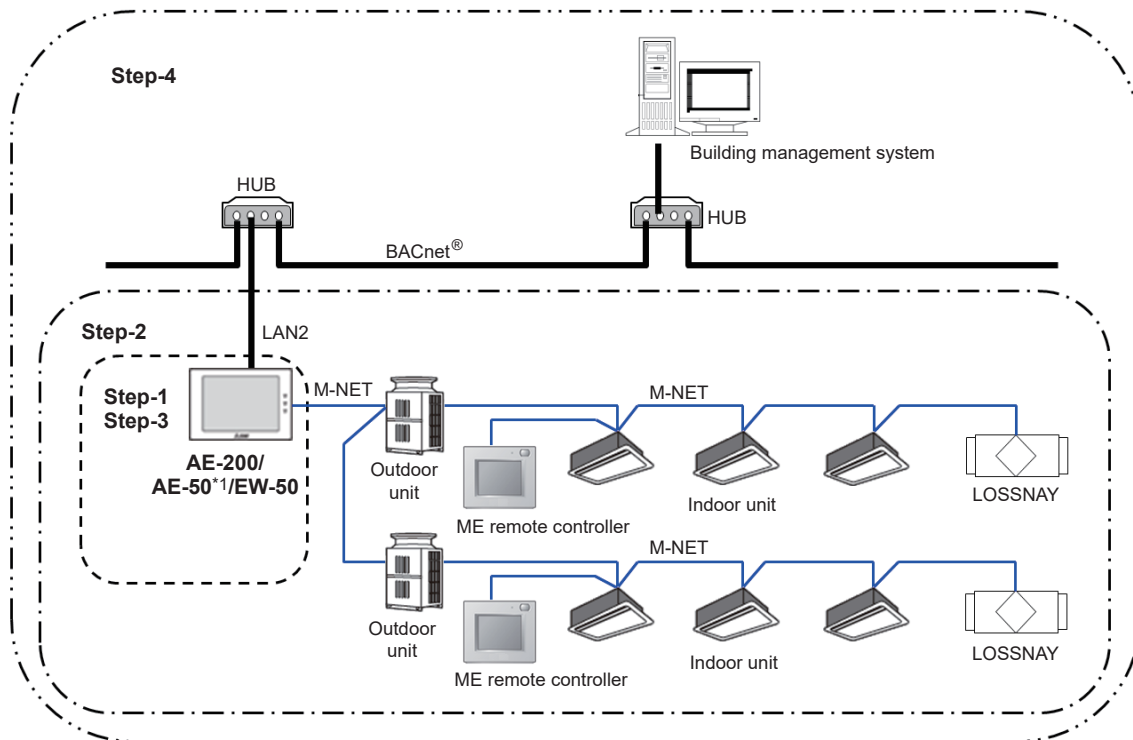

\*1 AE-50 is used only for monitoring multiple M-NET systems from a single AE-200 or for using the apportioned electricity billing function.

## 7-2. Preparatory items for initial settings

Prepare the following equipment and materials to make initial settings and trial run.

Item	Contents	Q'ty	Remarks
Required material	Diagram of air conditioning control system for building	1	Group configuration and IP address etc.
	Others *2	-	BACnet® devices list, notification items, documents related to notification destination and notification methods
Manual	AE-200/AE-50/EW-50 Instruction Book (BACnet® function)	1	(This manual)
	AE-200/AE-50/EW-50 Instruction Book (Initial Settings)	1	
	AE-200/AE-50/EW-50 Instruction Book (BACnet® Setting Tool)	1	
	AE-200/AE-50/EW-50 Installation Manual	1	Included with AE-200/AE-50/EW-50
	AE-200/AE-50/EW-50 Instruction Book (Apportioned Electricity Billing Function)	1	Used only when the apportioned electricity billing function is used.
	Instruction Book and Installation Manual of each air conditioning unit and controller	1	
Device/ equipment	PC *1	1	Used for operating Web browser/Initial Setting Tool/BACnet® Setting Tool
	BACnet® Setting Tool *3	1	
	BACnet® Trial Run Tool	1	Used for BACnet® trial run and log interval setting of the trend log.
	"BACnet connection" license	1	Consult your dealer for details.
	"Charge" license	1	Used only when the apportioned electricity billing function is used. Consult your dealer for details.
	Switching HUB	2	Used for connecting Initial Setting Tool/BACnet® Setting Tool
	LAN cable (Category 5 or above straight cable)	2	Used for connecting Initial Setting Tool/BACnet® Setting Tool
	General tools such as a screwdriver	1	
	Tester	1	Used for checking wiring and voltage

\*1 Refer to the AE-200/AE-50/EW-50 Instruction Book (Initial Settings) and the AE-200/AE-50/EW-50 Instruction Book (BACnet® Setting Tool) for required specs, etc.

\*2 When using the apportioned electricity billing function, materials and machine parts are required to configure the apportioned electricity billing function. Refer to the AE-200/AE-50/EW-50 Instruction Book (Apportioned Electricity Billing Function) for details.

\*3 BACnet® Setting Tool installer includes BACnet® Setting Tool and Initial Setting Tool.

### 7-3. Step-1 Initial settings for the air conditioning system

Make initial settings for the AE-200/AE-50/EW-50 using the Initial Setting Tool. Refer to the AE-200/AE-50/EW-50 Instruction Book (Initial Settings) for details.

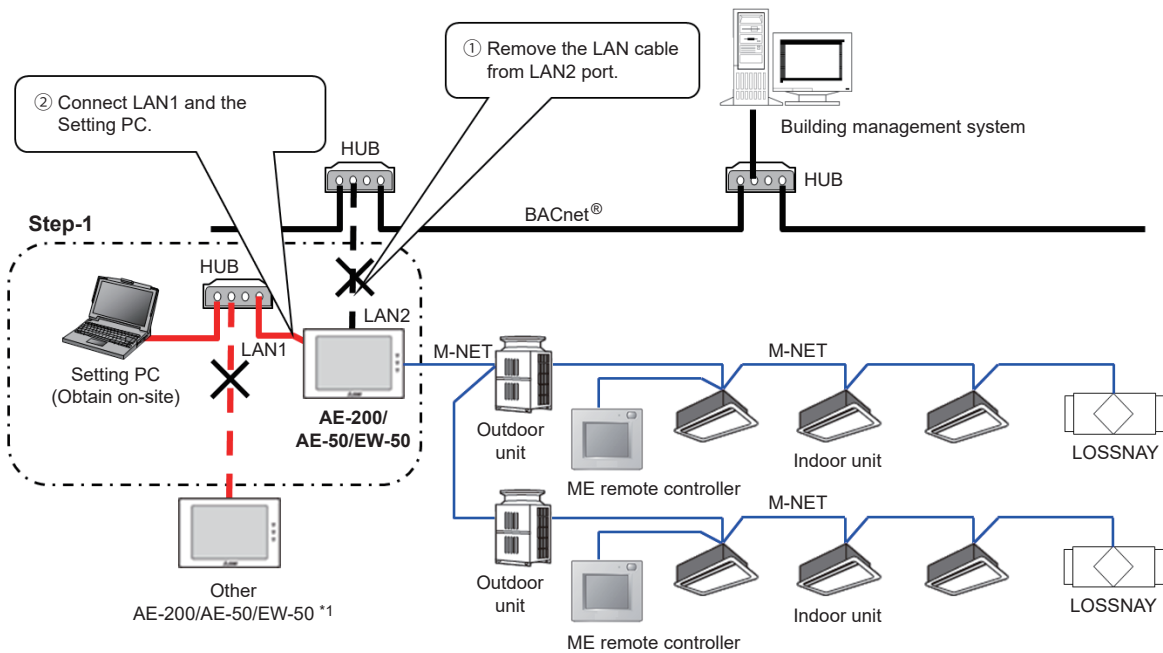

\*1 If the LAN1 connection between AE-200/AE-50/EW-50 is disconnected, then a communication error (6920) may be detected. In this process, ignore the communication error (6920).

#### (1) Setting Tool installation

Install the Initial Setting Tool and BACnet® Setting Tool on the Setting PC, and set the IP address for the Setting PC.

(Refer to the AE-200/AE-50/EW-50 Instruction Book (Initial Settings) and the AE-200/AE-50/EW-50 Instruction Book (BACnet® Setting Tool) for details.)

#### (2) Connecting the Setting PC

Before connecting the Setting PC to AE-200/AE-50/EW-50, remove the LAN cable connected to BACnet® from LAN2 of AE-200/AE-50/EW-50.

AE-200/AE-50/EW-50 (LAN1) and the Setting PC are connected via a HUB.

#### (3) Setting IP address and expansion controller

Make settings related to the IP address of LAN1 of AE-200/AE-50/EW-50 and the expansion controller on the AE-200/AE-50's LCD. (Refer to the AE-200/AE-50/EW-50 Instruction Book (Initial Settings) for the setting method.)

The settings can also be made using the Initial Setting Tool (AE-200/AE-50/EW-50, IP address only) or the Quick IP address setting switch (EW-50 only, IP address only).

The settings that can be made on the AE-200/AE-50's LCD are as follows.

No.	Main tab	Sub tab
1	Initial Settings	Network
2		Unit information

**(4) Time settings, software version upgrades, license registration**

Set the AE-200/AE-50/EW-50 time.

Upgrade the software versions to unify the software versions of all connected AE-200/AE-50/EW-50.

Register the license to use with the AE-200/AE-50/EW-50.

(Refer to the AE-200/AE-50/EW-50 Instruction Book (Initial Settings) for settings methods.)

**(5) Basic settings, unit settings, and floor settings**

Configure settings related to the air conditioning system using the Initial Setting Tool which has been installed on the Setting PC.

Items to be set are as follows.

(For the setting method, refer to the AE-200/AE-50/EW-50 Instruction Book (Initial Settings).)

No.	Main tab	Sub tab
1	Basic Settings	System Configuration
2		Basic System
3	Unit Settings	Groups
4		Refrigerant System
5		Interlocked LOSSNAY
6		Blocks
7		Energy Management Block *1
8		PI Controller
9		AI Controller
10	Floor Settings	Floor
11		Floor Layout
12		Floor for Integrated Centralized Control Web
13		Floor Layout for Integrated Centralized Control Web

\*1 The setting is required when an apportioned electricity billing function is used.

## 7-4. Step-2 Trial run of the air conditioning system

Carry out trial run only for the air conditioning system (within the dotted line in the diagram below). For details, refer to the Installation Manual of the AE-200/AE-50/EW-50.

\* A trial run of the air conditioning single unit should be completed beforehand and the following should be performed when it is in an operational state.

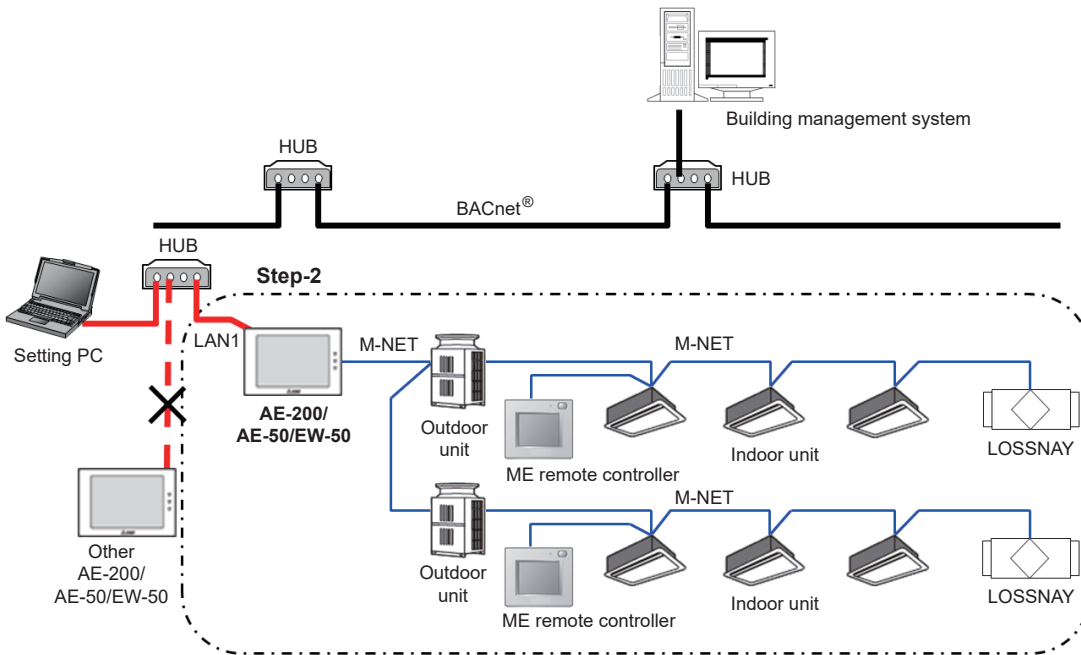

### (1) Trial run of the air conditioning units

Perform trial run operations from the AE-200/AE-50/EW-50 and check the operating state of each unit.

\* For the method of carrying out the trial run, refer to the Installation Manual for the air conditioning unit, local remote controller and AE-200/AE-50/EW-50.



## 7-5. Step-3 Initial settings for the BACnet® related items

Make the initial settings related to BACnet® using the BACnet® Setting Tool.

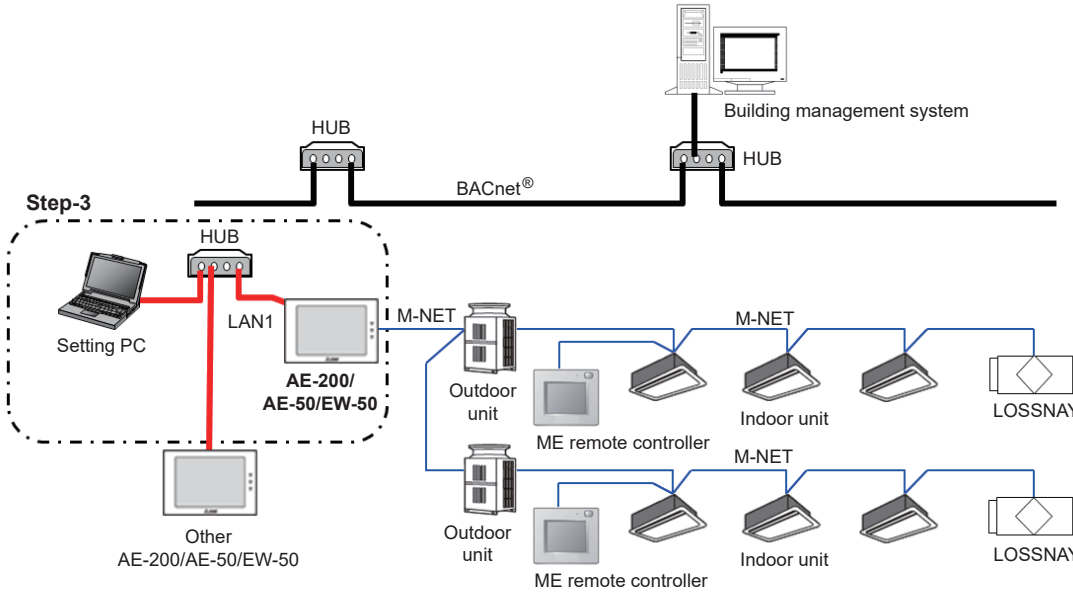

### (1) Data setting

LAN2 (BACnet®) settings and BACnet® related settings are made using the BACnet® Setting Tool which has been installed on the Setting PC. Because the BACnet® Setting Tool can only configure single AE-200/AE-50/EW-50 at one time, even when the system is configured with multiple AE-200/AE-50/EW-50 units, it is necessary to configure each AE-200/AE-50/EW-50 unit.

The setting items are as follows. (Refer to the AE-200/AE-50/EW-50 Instruction Book (BACnet® Setting Tool) for details for each of the items.)

#### ① LAN2 (BACnet®) settings

Settings are made for the IP address, subnet mask, and default gateway of LAN2 (BACnet®) of the AE-200/AE-50/EW-50.

No.	Main tab	Sub tab
1	System Settings	Basic Settings

#### Important

When the IP address of AE-200/AE-50/EW-50 overlaps the IP address of another unit inside the network, not only can AE-200/AE-50/EW-50 not carry out BACnet® communication normally but other devices also cannot carry out BACnet® communication normally. Before connecting AE-200/AE-50/EW-50 to BACnet®, check the IP address used on AE-200/AE-50/EW-50 and make settings.

#### ② BACnet® related settings

Settings are made for the device No. of AE-200/AE-50/EW-50, the notification destination and whether or not an object is used.

No.	Main tab	Sub tab
1	BACnet Settings	BACnet
2		Network and Device
3		COV Notification
4		Event Notification
5		Object
6		Other



## Method of carrying out trial runs for air conditioning control system (AE-200/AE-50/EW-50) BACnet<sup>®</sup> function

Check the objects used in the system.

Refer to the table in section 5-2-1 “Instance number for basic functions” as to whether or not objects can be supported by different unit types.

Object	Object ID	Status	Checking procedures
On Off Setup *1	BO_01xx01	INACTIVE(0): OFF ACTIVE(1): ON	(1)From the building management system, operate run/stop for a specific group. (2)Using AE-200/AE-50/EW-50 or the remote controller, check to see that the run/stop state of the relevant group is updated to an operating state.
On Off State	BI_01xx02	INACTIVE(0): OFF ACTIVE(1): ON	(1)Using AE-200/AE-50/EW-50 or the remote controller, operate run/stop of a specific group. (2)In the building management system, check to see that the state of run/stop of the relevant group is updated to the operating state.
Alarm Signal	BI_01xx03	INACTIVE(0): Normal ACTIVE(1): Error	(1)Cause air conditioning unit of a specific group to generate an error. (2)In the building management system, check to see that the alarm signal of the relevant group has been updated to “Error” (ACTIVE). *2 (3)Return from an error in an air conditioning unit of a specific group. (4)In the building management system, check to see that the alarm signal of the relevant group has been updated to “Normal” (INACTIVE).
Error Code	MI_01xx04	01: Normal 02: Other errors 03: Refrigeration system fault 04: Water system error 05: Air system error 06: Electronic system error 07: Sensor fault 08: Communication error 09: System error	(1)Remove the M-NET transmission line which is connected to the AE-200/AE-50/EW-50. *3 (2)In the building management system, check to see that error codes for all groups have been updated to “Communication error” (08). (3)Connect the M-NET transmission line to the AE-200/AE-50/EW-50. (4)In the building management system, check to see that error codes for all groups have been updated to “Normal” (01). (Perform this when no other errors have occurred. In addition, other errors may occur when there is a communication error, however, in this checking step, attention should be focused on error codes).
Operational Mode Setup	MO_01xx05	01: Cool 02: Heat 03: Fan 04: Auto 05: Dry *4 06: Setback *5	(1)From the building management system, change the operational mode for a specific group. (2)Using AE-200/AE-50/EW-50 or the remote controller, check to see that the operational mode for the relevant group is updated to the operating mode.

Object	Object ID	Status	Checking procedures
Operational Mode State	MI_01xx06	01: Cool 02: Heat 03: Fan 04: Auto 05: Dry *4 06: Setback *5	(1)Using AE-200/AE-50/EW-50 or the remote controller, change the operational mode for a specific group. (2)In the building management system, check to see that the operational mode for the relevant group has been updated to the operating mode.
Fan Speed Setup	MO_01xx07	01: Low 02: High 03: Mid 2 *6 04: Mid 1 *6 05: Auto	(1)From the building management system, change the fan speed for a specific group. (2)Using AE-200/AE-50/EW-50 or the remote controller, check to see that the fan speed for the relevant group is updated to the operating fan speed.
Fan Speed State	MI_01xx08	01: Low 02: High 03: Mid 2 *6 04: Mid 1 *6 05: Auto	(1)Using AE-200/AE-50/EW-50 or the remote controller, change the fan speed for a specific group. (2)In the building management system, check to see that the fan speed for the relevant group is updated to the operating fan speed.
Room Temp [Water Temp]	AI_01xx09	°F/°C (32°F–199°F/0.0°C– 99.0°C) *7	(1)Change the intake air temperature for a specific group by cooling or heating. (2)Check to see that the display on the building management system coincides with the display on the AE-200/AE-50/EW-50 or the remote controller. *17
Set Temp [Set Water Temp] *8	AV_01xx10	°F/°C (32°F–199°F/0.0°C– 99.0°C) *7	(1)From the building management system, set the set temperature for a specific group. (2)Using AE-200/AE-50/EW-50 or the remote controller, check to see that the set temperature for the relevant group has been updated to an operating value. (3)Using AE-200/AE-50/EW-50 or the remote controller, change the set temperature for a specific group. (4)In the building management system, check to see that the set temperature for the relevant group has been updated to the operating value.
Set Temp Cool *8	AV_01xx24	°F/°C (32°F–199°F/0.0°C– 99.0°C) *7	(1)From the building management system, set the cooling set temperature for a specific group. (2)Using AE-200/AE-50/EW-50 or the remote controller, check to see that the cooling set temperature for the relevant group has been updated to an operating value. (3)Using AE-200/AE-50/EW-50 or the remote controller, change the cooling set temperature for a specific group. (4)In the building management system, check to see that the cooling set temperature for the relevant group has been updated to the operating value.

Object	Object ID	Status	Checking procedures
Set Temp Heat *8	AV_01xx25	°F/°C (32°F–199°F/0.0°C–99.0°C) *7	<ol style="list-style-type: none"> <li>(1) From the building management system, set the heating set temperature for a specific group.</li> <li>(2) Using AE-200/AE-50/EW-50 or the remote controller, check to see that the heating set temperature for the relevant group has been updated to an operating value.</li> <li>(3) Using AE-200/AE-50/EW-50 or the remote controller, change the heating set temperature for a specific group.</li> <li>(4) In the building management system, check to see that the heating set temperature for the relevant group has been updated to the operating value.</li> </ol>
Set Temp Auto *8	AV_01xx26	°F/°C (32°F–199°F/0.0°C–99.0°C) *7	<ol style="list-style-type: none"> <li>(1) From the building management system, set the set temperature (single-set-point in the Auto mode) for a specific group.</li> <li>(2) Using AE-200/AE-50/EW-50 or the remote controller, check to see that the set temperature (single-set-point in the Auto mode) for the relevant group has been updated to an operating value.</li> <li>(3) Using AE-200/AE-50/EW-50 or the remote controller, change the set temperature (single-set-point in the Auto mode) for a specific group.</li> <li>(4) In the building management system, check to see that the set temperature (single-set-point in the Auto mode) for the relevant group has been updated to the operating value.</li> </ol>
Set High Limit Setback Temp *5	AV_01xx27	°F/°C (32°F–199°F/0.0°C–99.0°C) *7	<ol style="list-style-type: none"> <li>(1) From the building management system, set the set temperature (upper limit in the Setback mode) for a specific group.</li> <li>(2) Using AE-200/AE-50/EW-50 or the remote controller, check to see that the set temperature (upper limit in the Setback mode) for the relevant group has been updated to an operating value.</li> <li>(3) Using AE-200/AE-50/EW-50 or the remote controller, change the set temperature (upper limit in the Setback mode) for a specific group.</li> <li>(4) In the building management system, check to see that the set temperature (upper limit in the Setback mode) for the relevant group has been updated to the operating value.</li> </ol>
Set Low Limit Setback Temp *5	AV_01xx28	°F/°C (32°F–199°F/0.0°C–99.0°C) *7	<ol style="list-style-type: none"> <li>(1) From the building management system, set the set temperature (lower limit in the Setback mode) for a specific group.</li> <li>(2) Using AE-200/AE-50/EW-50 or the remote controller, check to see that the set temperature (lower limit in the Setback mode) for the relevant group has been updated to an operating value.</li> <li>(3) Using AE-200/AE-50/EW-50 or the remote controller, change the set temperature (lower limit in the Setback mode) for a specific group.</li> <li>(4) In the building management system, check to see that the set temperature (lower limit in the Setback mode) for the relevant group has been updated to the operating value.</li> </ol>

Object	Object ID	Status	Checking procedures
Filter Sign [Circulating Water Exchange Sign]	BI_01xx11	INACTIVE(0): OFF ACTIVE(1): ON	<ol style="list-style-type: none"> <li>(1) Issue the filter sign (circulating water exchange sign) for a specific group.</li> <li>(2) In the building management system, check to see that the filter sign (circulating water exchange sign) for the relevant group has been updated to "ON" (ACTIVE).</li> </ol>
Filter Sign Reset [Circulating Water Exchange Sign Reset]	BV_01xx12	INACTIVE(0): Reset ACTIVE(1): Void	<ol style="list-style-type: none"> <li>(1) From the building management system, carry out operations for filter sign reset (circulating water exchange sign reset) for the group which has detected ("ON" (ACTIVE)) filter sign (circulating water exchange sign).</li> <li>(2) In the building management system, check to see that filter sign (circulating water exchange sign) of the relevant group has been updated to "OFF" (INACTIVE).</li> </ol>
Prohibition On Off *1	BV_01xx13	INACTIVE(0): Permit ACTIVE(1): Prohibit	<ol style="list-style-type: none"> <li>(1) From the building management system, carry out prohibition operation for remote controller operation (run/stop) for a specific group.</li> <li>(2) Check to see that run/stop operations have been prohibited by the remote controller in the relevant group.</li> <li>(3) From the building management system, carry out permission operation for remote controller operation (run/stop) for a specific group.</li> <li>(4) Check to see that run/stop operations have been permitted by the remote controller in the relevant group.</li> </ol>
Prohibition Mode	BV_01xx14	INACTIVE(0): Permit ACTIVE(1): Prohibit	<ul style="list-style-type: none"> <li>• Although the operating target is an operational mode, the checking method is the same as "Prohibition On Off" above.</li> </ul>
Prohibition Filter Sign Reset [Prohibition Circulating Water Exchange Sign Reset]	BV_01xx15	INACTIVE(0): Permit ACTIVE(1): Prohibit	<ul style="list-style-type: none"> <li>• Although the operating target is resetting filter sign (circulating water exchange sign), the checking method is the same as "Prohibition On Off" above.</li> </ul>
Prohibition Set Temperature	BV_01xx16	INACTIVE(0): Permit ACTIVE(1): Prohibit	<ul style="list-style-type: none"> <li>• Although the operating target is a set temperature, the checking method is the same as "Prohibition On Off" above.</li> </ul>
Prohibition Fan Speed	BV_01xx17	INACTIVE(0): Permit ACTIVE(1): Prohibit	<ul style="list-style-type: none"> <li>• Although the operating target is a fan speed, the checking method is the same as "Prohibition On Off" above.</li> </ul>
M-NET Communication State	BI_01xx20	INACTIVE(0): Normal ACTIVE(1): Error	<ol style="list-style-type: none"> <li>(1) Remove the M-NET transmission line which is connected to the AE-200/AE-50/EW-50. *3</li> <li>(2) In the building management system, check to see that the M-NET communication status of all groups has been updated to "Error" (ACTIVE).</li> <li>(3) Connect the M-NET transmission line to the AE-200/AE-50/EW-50.</li> <li>(4) In the building management system, check to see that the M-NET communication state for all groups has been updated to "Normal" (INACTIVE). (Other errors occur when there is a communication error, however, in this checking step, attention should be focused on the M-NET communication state).</li> </ol>

Object	Object ID	Status	Checking procedures
System Forced Off (individual)	BV_01xx21	INACTIVE(0): Reset ACTIVE(1): Execute	<ol style="list-style-type: none"> <li>(1)Set "External Input Setting" of the AE-200/AE-50/EW-50 to "Demand (Level signal)/Not in use" *9 and operate emergency stop for a specific group from the building management system.</li> <li>(2)In the building management system, check to see that the air conditioning units of the relevant group are stopped. Also, check to see that run/stop operations have been prohibited by the remote controller in the relevant group.</li> <li>(3)From the building management system, carry out emergency stop release for a specific group.</li> <li>(4)Check to see that run/stop operations have been permitted by the remote controller in the relevant group.</li> </ol>
System Forced Off (collective)	BV_019921	INACTIVE(0): Reset ACTIVE(1): Execute	<ol style="list-style-type: none"> <li>(1)Set "External Input Setting" of the AE-200/AE-50/EW-50 to "Demand (Level signal)/Not in use" *9 and carry out batch emergency stop from the building management system.</li> <li>(2)In the building management system, check to see that all air conditioning units have been stopped. Also, check to see that run/stop operations have been prohibited by all remote controllers.</li> <li>(3)From the building management system, carry out batch emergency stop release.</li> <li>(4)Check to see that run/stop operations have been permitted by all remote controllers.</li> </ol>
Air Direction Setup	MO_01xx22	01: Horizontal 02: Downblow 60% 03: Downblow 80% 04: Downblow 100% 05: Swing	<ol style="list-style-type: none"> <li>(1)From the building management system, change the air direction for a specific group.</li> <li>(2)Using AE-200/AE-50/EW-50 or the remote controller, check to see that the air direction for the relevant group is updated to the operating air direction.</li> </ol>
Air Direction State	MI_01xx23	01: Horizontal 02: Downblow 60% 03: Downblow 80% 04: Downblow 100% 05: Swing	<ol style="list-style-type: none"> <li>(1)Using AE-200/AE-50/EW-50 or the remote controller, change the air direction for a specific group.</li> <li>(2)In the building management system, check to see that the air direction for the relevant group is updated to the operating air direction.</li> </ol>
Ventilation Mode Setup	MO_01xx35	01: Heat Recovery 02: Bypass 03: Auto	<ol style="list-style-type: none"> <li>(1)From the building management system, change the ventilation mode for a specific group.</li> <li>(2)Using AE-200/AE-50/EW-50 or the remote controller, check to see that the ventilation mode for the relevant group is updated to the operating mode.</li> </ol>
Ventilation Mode State	MI_01xx36	01: Heat Recovery 02: Bypass 03: Auto	<ol style="list-style-type: none"> <li>(1)Using AE-200/AE-50/EW-50 or the remote controller, change the ventilation mode for a specific group.</li> <li>(2)In the building management system, check to see that the ventilation mode for the relevant group is updated to the operating mode.</li> </ol>
Air To Water Mode Setup	MO_01xx37	01: Heating 02: Heating ECO 03: Hot Water 04: Anti-freeze 05: Cooling	<ol style="list-style-type: none"> <li>(1)From the building management system, change the Air To Water mode for a specific group.</li> <li>(2)Using AE-200/AE-50/EW-50 or the remote controller, check to see that the Air To Water mode for the relevant group is updated to the operating mode.</li> </ol>



Object	Object ID	Status	Checking procedures
Air To Water Mode State	MI_01xx38	01: Heating 02: Heating ECO 03: Hot Water 04: Anti-freeze 05: Cooling	(1)Using AE-200/AE-50/EW-50 or the remote controller, change the Air To Water mode for a specific group. (2)In the building management system, check to see that the Air To Water mode for the relevant group is updated to the operating mode.
System Alarm Signal	BI_010048	INACTIVE(0): Normal ACTIVE(1): Error	(1)Remove the M-NET transmission line which is connected to the AE-200/AE-50/EW-50. *3 (2)In the building management system, check to see that system alarm signal has been updated to "Error" (ACTIVE). *10 (3)Connect the M-NET transmission line to the AE-200/AE-50/EW-50. (4)In the building management system, check to see that the system alarm signal has been updated to "Normal" (INACTIVE). (Other errors occur when there is a communication error, however, in this checking step, attention should be focused on the system alarm signal).
Error Code Detail	AI_01xx49	Normal: 8000 Error: Error code (4 digits)	(1)Remove the M-NET transmission line which is connected to the AE-200/AE-50/EW-50. *3 (2)In the building management system, check to see that Error Code Detail for all groups have been updated to "M-NET communication error" (660*). (3)Connect the M-NET transmission line to the AE-200/AE-50/EW-50. (4)In the building management system, check to see that Error Code Detail for all groups have been updated to "Normal" (8000). (Perform this when no other errors have occurred. In addition, other errors may occur when there is a communication error, however, in this checking step, attention should be focused on Error Code Detail).
PIcontroller Alarm Signal	BI_41mm03	INACTIVE(0): Normal ACTIVE(1): Error	(1)Remove the M-NET transmission line which is connected to a specific PI controller. (2)In the building management system, check to see that PI controller alarm signal for the relevant PI controller has been updated to "Error" (ACTIVE). *11 (3)Connect the M-NET transmission line to a specific PI controller. (4)In the building management system, check to see that PI controller alarm signal for the relevant PI controller has been updated to "Normal" (INACTIVE).



Object	Object ID	Status	Checking procedures
Group Apportioned Electric Energy *12 *13 *14	AC_01xx39	0–999,999,999 [0.1 kWh]	<p>(1)From the building management system, set the current values for electric energy (indoor unit + outdoor unit) for each group in a specific group in the “Value_Set” property. Alternatively, in the building management system, record the current values for electric energy (indoor unit + outdoor unit) for each specific group.</p> <p>(2)Operate the air conditioning units in the relevant group continuously for at least two hours.</p> <p>(3)In the building management system, obtain electric energy (indoor unit + outdoor unit) for each group in the relevant group, total the difference with the value set in the “Value_Set” property (or the electric energy recorded in (1)) for each energy management block, and check (using a CSV file) to see that this coincides with the energy management block apportioned electric energy.</p>
Interlocked Units Apportioned Electric Energy *12 *13 *14	AC_61aa39	0–999,999,999 [0.1 kWh]	<p>(1)From the building management system, without registering this in a group, set the current values for electric energy (indoor unit + outdoor unit) for specific OA Processing Unit which has been set as an interlocked unit in the “Value_Set” property. Alternatively, in the building management system, without registering this in a group, record the current values for electric energy (indoor unit + outdoor unit) for specific OA Processing Unit which has been set as an interlocked unit.</p> <p>(2)Operate the relevant interlocked units continuously for at least two hours.</p> <p>(3)In the building management system, obtain electric energy (indoor unit + outdoor unit) for the relevant interlocked unit, total the difference with the value set in the “Value_Set” property (or the electric energy recorded in (1)) for each energy management block, and check (using a CSV file) to see that this coincides with the energy management block apportioned electric energy.</p>
PIcontroller Electric Energy 1–4 *12 *13 *14	AC_41mm40–43	0–999,999,999 [0.1 kWh]	<p>(1)From the building management system, set the current value for electric energy for the electricity meter (1 to 4) connected to the PI controller pulse input in the “Value_Set” property. Alternatively, in the building management system, record the current value for electric energy for the electricity meter (1 to 4) connected to the PI controller pulse input.</p> <p>(2)Operate devices connected to the electricity meter (1 to 4) connected to pulse input of the PI controller continuously for at least two hours.</p> <p>(3)In the building management system, check (using a CSV file) to see that the electric energy (or difference between the current electric energy and that recorded in (1)) coincides with the reading of the metering device of AE-200/AE-50/EW-50.</p>

Object	Object ID	Status	Checking procedures
Pulse Input Electric Energy 1–4 *12 *13 *14	AC_410040–43	0–999,999,999 [0.1 kWh]	<p>(1)From the building management system, set the current value for electric energy for the electricity meter (1 to 4) connected to the AE-50/EW-50 built-in Pulse Input (PI) in the “Value_Set” property. Alternatively, in the building management system, record the current value for electric energy for the electricity meter (1 to 4) connected to the AE-50/EW-50 built-in Pulse Input (PI).</p> <p>(2)Operate devices connected to the electricity meter (1 to 4) connected to the built-in pulse input (PI) of the AE-50/EW-50 continuously for at least two hours.</p> <p>(3)In the building management system, check (using a CSV file) to see that the electric energy (or difference between the current electric energy and that recorded in (1)) coincides with the reading of the metering device of AE-200/AE-50/EW-50.</p>
Group Apportionment Parameter *12 *13 *15	AC_01xx44	0–999,999,999 [0.1 (No Units)]	<p>(1)From the building management system, set the current values for apportionment parameter (outdoor unit) for each group in a specific group in the “Value_Set” property. Alternatively, in the building management system, record the current values for apportionment parameter (outdoor unit) for each specific group.</p> <p>(2)Operate the air conditioning units in the relevant group for at least two hours continuously.</p> <p>(3)In the building management system, obtain apportionment parameter (outdoor unit) for each group in the relevant group, total the difference with the value set in the “Value_Set” property (or the electric energy recorded in (1)) for each energy management block, and check (using a CSV file) to see that this coincides with the outdoor unit apportionment parameter of the energy management block.</p>
Interlocked Units Apportionment Parameter *12 *13 *15	AC_61aa44	0–999,999,999 [0.1 (No Units)]	<p>(1)From the building management system, without registering this in a group, set the current values for apportionment parameter (outdoor unit) for specific OA Processing Unit which has been set as an interlocked unit in the “Value_Set” property. Alternatively, in the building management system, without registering this in a group, record the current values for apportionment parameter (outdoor unit) for the specific OA Processing Unit which has been set as an interlocked unit.</p> <p>(2)Operate the relevant interlocked units continuously for at least two hours.</p> <p>(3)In the building management system, obtain apportionment parameter (outdoor unit) for the relevant interlocked unit, total the difference with the value set in the “Value_Set” property (or the apportionment parameter recorded in (1)) for each energy management block, and check (using a CSV file) to see that this coincides with the outdoor unit apportionment parameter of the energy management block.</p>

Object	Object ID	Status	Checking procedures
Night Purge State	BI_01xx46	INACTIVE(0): OFF ACTIVE(1): ON	<p>(1)Using AE-200/AE-50/EW-50 or the remote controller, run Night Purge for LOSSNAY of a specific group.</p> <p>(2)In the building management system, check to see that the status of Night Purge of the relevant group has been updated to "ON".</p> <p>(3)Using AE-200/AE-50/EW-50 or the remote controller, stop Night Purge for LOSSNAY of a specific group.</p> <p>(4)In the building management system, check to see that the status of Night Purge of the relevant group has been updated to "OFF".</p>
Thermo On Off State	BI_01xx47	INACTIVE(0): Thermo OFF ACTIVE(1): Thermo ON	<p>(1)Using AE-200/AE-50/EW-50 or the remote controller, have a specific group perform fan operation.</p> <p>(2)In the building management system, check to see that the thermo ON/OFF status of the relevant group has been updated to "Thermo OFF".</p> <p>(3)Using AE-200/AE-50/EW-50 or the remote controller, cool a specific group using a low temperature setting of at least 2°C lower than the room temperature or heat at a high temperature setting of at least 2°C higher than the room temperature.</p> <p>(4)In the building management system, check to see that the thermo ON/OFF status of the relevant group has been updated to "Thermo ON".</p>
External Heat Source State	BI_01xx50	INACTIVE(0): OFF ACTIVE(1): ON	<p>(1)Change the ON/OFF conditions of the external heat source that is connected to the indoor unit CN24 of the specific group.</p> <p>(2)In the building management system, check to see that the state of External heat source for the relevant group is updated to the changed value.</p>
Trend Log Room Temp *16	LOG_01xx80		<p>(1)Record the "Room Temp" value and check the log record of the "LogBuffer" property and check that the "Room Temp" data has been logged in after the time longer than collection cycle that is set from the building management system has been elapsed.</p>
Trend Log Group Apportioned Electric Energy *12 *14 *16	LOG_01xx83		<p>(1)Record the "Group Apportioned Electric Energy" value and check the log record of the "LogBuffer" property and check that the "Group Apportioned Electric Energy" data has been logged in after the time longer than collection cycle that is set from the building management system has been elapsed.</p>
Trend Log Interlocked Units Apportioned Electric Energy *12 *14 *16	LOG_61aa83		<p>(1)Record the "Interlocked Units Apportioned Electric Energy" value and check the log record of the "LogBuffer" property and check that the "Interlocked Units Apportioned Electric Energy" data has been logged in after the time longer than collection cycle that is set from the building management system has been elapsed.</p>
Trend Log PIcontroller Electric Energy 1-4 *12 *14 *16	LOG_41mm84~87		<p>(1)Record the "PIcontroller Electric Energy 1-4" value and check the log record of the "LogBuffer" property and check that the "PIcontroller Electric Energy 1-4" data has been logged in after the time longer than collection cycle that is set from the building management system has been elapsed.</p>

Object	Object ID	Status	Checking procedures
Trend Log Pulse Input Electric Energy 1–4 *12 *14 *16	LOG_410084~87		(1)Record the “Pulse Input Electric Energy 1–4” value and check the log record of the “LogBuffer” property and check that the “Pulse Input Electric Energy 1–4” data has been logged in after the time longer than collection cycle that is set from the building management system has been elapsed.
Trend Log Group Apportionment Parameter *12 *15 *16	LOG_01xx88		(1)Record the “Group Apportionment parameter” value and check the log record of the “LogBuffer” property and check that the “Group Apportionment parameter” data has been logged in after the time longer than collection cycle that is set from the building management system has been elapsed.
Trend Log Interlocked Units Apportionment Parameter *12 *15 *16	LOG_61aa88		(1)Record the “Interlocked Units Apportionment Parameter” value and check the log record of the “LogBuffer” property and check that the “Interlocked Units Apportionment Parameter” data has been logged in after the time longer than collection cycle that is set from the building management system has been elapsed.

\* xx: Group number (01–50)

\* mm: PI controller address (01–50)

\* aa: Interlocked unit address (01–50)

- \*1 Do not use this when “External Input Setting” for AE-200/AE-50/EW-50 is set to “ON/OFF (Level signal)”. “External Input Setting” can be configured on the Initial Setting Tool, Web Browser for Initial Settings, or AE-200/AE-50’s LCD. (Refer to the AE-200/AE-50/EW-50 Instruction Book (Initial Settings) for settings methods.)
- \*2 The air conditioning unit error code (4 digits) is output to the Description and the Message Text of event notification. When an error occurs, check to see that it coincides with the error code (4 digits) detected by AE-200/AE-50/EW-50 or the remote controller.
- \*3 When the M-NET transmission line has been removed, units in a group with no remote controller stop.
- \*4 “Dry” can be used only when the “Use Dry Mode” setting is enabled (checked) on the BACnet® Setting Tool. (The default setting is disabled (unchecked).)
- \*5 It can only be used if the system controller is AE-200A/AE-50A/EW-50A and the indoor unit is a Setback mode supported model.
- \*6 “Mid 1” and “Mid 2” can be used only when the “Use Fan Speed Mid1/Mid2” setting is enabled (checked) on the BACnet® Setting Tool. (The default setting is disabled (unchecked).)
- \*7 Accuracy and value ranges in BACnet®. Accuracy and value ranges that can be actually set or measured will differ depending on the model of the connected air conditioning units and remote controllers.
- \*8 The objects that can be used for the temperature setting differ depending on the model and the setting. Refer to section 5-3 “Set temperature objects” for details.
- \*9 For details of the setting method, refer to the item in “External Input Setting” in the AE-200/AE-50/EW-50 Instruction Book (Initial Settings).
- \*10 The error code (4 digits) is output to the Description and the Message Text of event notification. When an error occurs, check to see that it coincides with the error code (4 digits) detected by AE-200/AE-50/EW-50.
- \*11 Outputs the PI controller error code (4 digits) to the Description and EVENT Notification Message Text. Check that when an error occurs, this matches the error code (4 digits) detected with the AE-200/AE-50/EW-50.
- \*12 When “Charge” license is not registered, the correct value is not stored.
- \*13 Results until XX:00 and XX:30 minutes every hour are reflected at XX:15 and XX:45 respectively.
- \*14 Can be used only if there is a metering device.
- \*15 Can be used only when there is no metering device.
- \*16 The initial value of the log interval of the trend log is 1 minute (Room Temp) or 30 minutes (other than Room Temp). To change the log interval, it is necessary to write (WriteProperty) in the “Log\_Interval” property from BACnet® Trial Run Tool before trial run.
- \*17 When the display temperature of the building management system is updated by COV notification, the difference of a maximum of [COV\_Increment setting value + 0.1]°C can be generated between the temperatures displayed on the building management system and on the AE-200/AE-50/EW-50. If the difference of the display temperature is within this value, assume that there is no difference.

**Air conditioning control system (AE-200/AE-50/EW-50) BACnet® function trial run check list example**

Object	Object ID	Results
On Off Setup	BO_01xx01	
On Off State	BI_01xx02	
Alarm Signal (4-digit error code)	BI_01xx03	
Error Code	MI_01xx04	
Operational Mode Setup	MO_01xx05	
Operational Mode State	MI_01xx06	
Fan Speed Setup	MO_01xx07	
Fan Speed State	MI_01xx08	
Room Temp [Water Temp]	AI_01xx09	
Set Temp [Set Water Temp]	AV_01xx10	
Set Temp Cool	AV_01xx24	
Set Temp Heat	AV_01xx25	
Set Temp Auto	AV_01xx26	
Filter Sign [Circulating Water Exchange Sign]	BI_01xx11	
Filter Sign Reset [Circulating Water Exchange Sign Reset]	BV_01xx12	
Prohibition On Off	BV_01xx13	
Prohibition Mode	BV_01xx14	
Prohibition Filter Sign Reset [Prohibition Circulating Water Exchange Sign Reset]	BV_01xx15	
Prohibition Set Temperature	BV_01xx16	
Prohibition Fan Speed	BV_01xx17	
M-NET Communication State	BI_01xx20	
System Forced Off	individual	BV_01xx21
	collective	BV_019921
Air Direction Setup	MO_01xx22	
Air Direction State	MI_01xx23	
Set High Limit Setback Temp	AV_01xx27	
Set Low Limit Setback Temp	AV_01xx28	
Ventilation Mode Setup	MO_01xx35	
Ventilation Mode State	MI_01xx36	
Air To Water Mode Setup	MO_01xx37	
Air To Water Mode State	MI_01xx38	
System Alarm Signal (4-digit error code)	BI_010048	
Error Code Detail	AI_01xx49	
Plcontroller Alarm Signal (4-digit error code)	BI_41mm03	
Group Apportioned Electric Energy	AC_01xx39	
Interlocked Units Apportioned Electric Energy	AC_61aa39	
Plcontroller Electric Energy 1–4	AC_41mm40–43	
Pulse Input Electric Energy 1–4	AC_410040–43	
Group Apportionment Parameter	AC_01xx44	
Interlocked Units Apportionment Parameter	AC_61aa44	
Night Purge State	BI_01xx46	
Thermo On Off State	BI_01xx47	
External Heat Source State	BI_01xx50	
Trend Log Room Temp	LOG_01xx80	
Trend Log Group Apportioned Electric Energy	LOG_01xx83	
Trend Log Interlocked Units Apportioned Electric Energy	LOG_61aa83	
Trend Log Plcontroller Electric Energy 1–4	LOG_41mm84–87	
Trend Log Pulse Input Electric Energy 1–4	LOG_410084–87	

Object	Object ID	Results
Trend Log Group Apportionment Parameter	LOG_01xx88	
Trend Log Interlocked Units Apportionment Parameter	LOG_61aa88	

\* xx: Group number (01–50), mm: PI controller address (01–50), aa: Interlocked unit address (01–50)

## 7-7. When changing settings or reconfiguring AE-200/AE-50/EW-50

The procedures for changing settings or reconfiguring AE-200/AE-50/EW-50 using stored settings data are as follows.

### Important

When AE-200/AE-50/EW-50 is reconfigured, communication with the building management system is temporarily cut off and the building management system may detect a communication error. Carry out operations after receiving approval from the building manager beforehand.

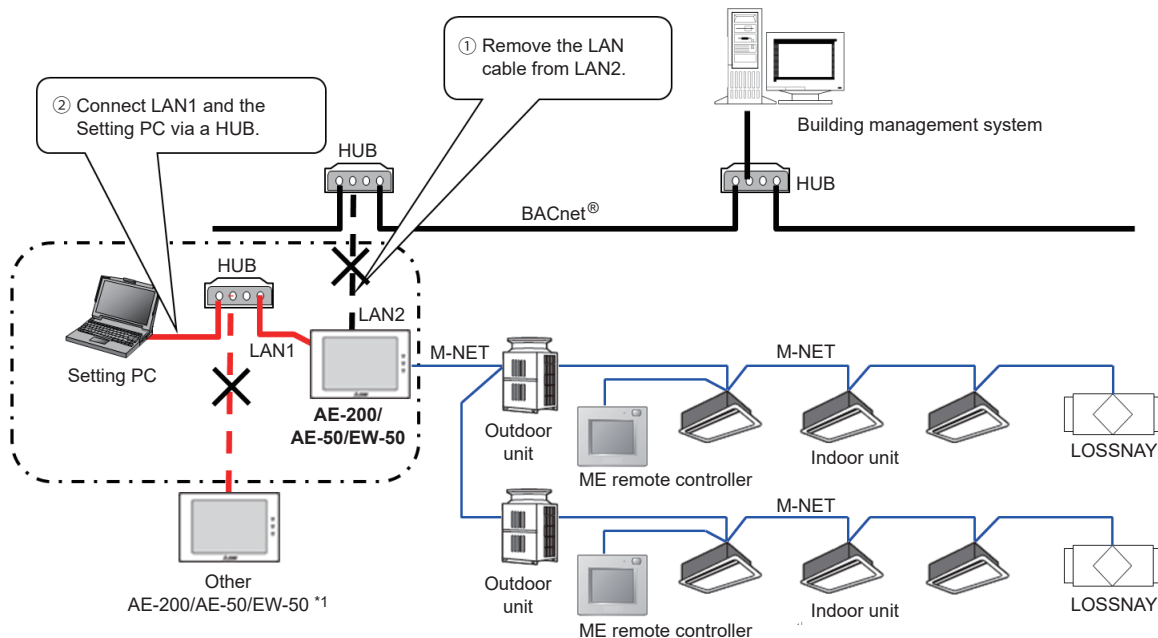

\*1 If the LAN1 connection between AE-200/AE-50/EW-50 is disconnected, then a communication error (6920) may be detected. In this process, ignore the communication error (6920).

### (1) Connecting Setting PC

Before the Setting PC is connected to AE-200/AE-50/EW-50, remove the LAN cable of LAN2 of AE-200/AE-50/EW-50 connected to BACnet®.

Connect the LAN 1 of AE-200/AE-50/EW-50 and the Setting PC using a LAN cable via a HUB.

### (2) Data setting

Setting changes are made on the Setting PC or the setting data stored is read to reconfigure AE-200/AE-50/EW-50.

Settings are performed for initial settings in the air conditioning system, the apportioned electricity billing function settings (only when used) and the BACnet® related settings, in that order.

(For details on setting items and settings in each procedure, refer to section 7-3 “Step-1 Initial settings for the air conditioning system”, AE-200/AE-50/EW-50 Instruction Book (Apportioned Electricity Billing Function), section 7-5 “Step-3 Initial settings for the BACnet® related items”, and AE-200/AE-50/EW-50 Instruction Book (BACnet® Setting Tool).)

Before configuring the BACnet® related items, it is required to set the BACnet® connection mode to “OFFLINE” from the BACnet® Setting Tool.

### (3) Air-conditioning system and apportioned electricity billing function trial run

Carry out a trial run for the air conditioning system and a trial run for the apportioned electricity billing function. Refer to the respective unit Installation Manual for the method of carrying out a trial run of the air conditioning system and the AE-200/AE-50/EW-50 Instruction Book (Apportioned Electricity Billing Function) for the method of carrying out a trial run of the apportioned electricity billing function.

### (4) ONLINE setting

A setting is made to “ONLINE” from the BACnet® Setting Tool. AE-200/AE-50/EW-50 restarts automatically. (approximately 10 minutes for maximum time required)

When AE-200/AE-50/EW-50 restarts, a group device with no remote controller may stop.

**(5) Removing Setting PC**

Remove the Setting PC from LAN1 of AE-200/AE-50/EW-50.

**(6) Connecting BACnet®**

Connect LAN2 of AE-200/AE-50/EW-50 and BACnet®.

**(7) BACnet® trial run**

By performing a trial run of the BACnet® function, check the operation. Refer to section 7-6 “Step-4 Trial run of BACnet® function” for the trial run method.



## Appendix: Added functions

The added functions are as follows.

Version	Added item	Description	Reference
Ver. 7.30	BACnet <sup>®</sup> function	The air conditioning units can be monitored and operated from the building management system using the BACnet <sup>®</sup> communication protocol.	All items other than the items below
Ver. 7.45	Specification change of the apportioned electricity billing function	The trend log collection cycle is changed to 30 minutes.	Section 5-5-1 "Apportioned electricity billing function specifications"
Ver. 7.50	Objects added	The following three objects were added. <ul style="list-style-type: none"> <li>• Prohibition Fan Speed</li> <li>• Error Code Detail</li> <li>• External Heat Source State</li> </ul>	Section 4-3 "Objects" Section 5-1 "Controller functions and BACnet <sup>®</sup> functions" Section 5-2-1 "Instance number for basic functions" Section 5-6 "Alarm Signal" Section 5-7-1 "Event service of objects" Section 5-8 "BACnet <sup>®</sup> information and storage timing/cycle in nonvolatile memory within the AE-200/AE-50/EW-50" Section 7-6 "Step-4 Trial run of BACnet <sup>®</sup> function"





---

This product is designed and intended for use in the residential,  
commercial and light-industrial environment.

The product at hand is based on the following EU regulations:

- Low Voltage Directive 2014/35/EU
- Electromagnetic Compatibility Directive 2014/30/EU
- Restriction of Hazardous Substances 2011/65/EU

Please be sure to put the contact address/telephone number  
on this manual before handing it to the customer.

## **MITSUBISHI ELECTRIC CORPORATION**

HEAD OFFICE: TOKYO BLDG., 2-7-3, MARUNOUCHI, CHIYODA-KU, TOKYO 100-8310, JAPAN  
MANUFACTURER: MITSUBISHI ELECTRIC CORPORATION Air-conditioning & Refrigeration Systems Works  
5-66, Tebira 6 Chome, Wakayama-city, 640-8686, Japan

WT07919X05