

PEFY-P- VMHS-E-F

1. SPECIFICATIONS	1 - 120
2. EXTERNAL DIMENSIONS	1 - 121
3. CENTER OF GRAVITY	1 - 125
4. ELECTRICAL WIRING DIAGRAMS	1 - 126
5. SOUND LEVELS	1 - 128
5-1. Sound levels	1 - 128
5-2. NC curves in normal-airflow rate mode	1 - 129
5-3. NC curves in high-airflow rate mode.....	1 - 130
6. FAN CHARACTERISTICS CURVES	1 - 131
6-1. Fan characteristics curves in normal-airflow rate mode	1 - 131
6-2. Fan characteristics curves in high-airflow rate mode.....	1 - 133
7. CAPACITY TABLES	1 - 135
7-1. Cooling capacity	1 - 135
7-2. Outlet air temp. cooled.....	1 - 136
7-3. Heating capacity	1 - 137
7-4. Outlet air temp. heated	1 - 138
8. ELECTRICAL CHARACTERISTICS.....	1 - 139
9. OPTIONAL PARTS.....	1 - 140
9-1. Optional parts line up for the Indoor unit.....	1 - 140
9-2. Long-life filter	1 - 140
9-3. Drain pump	1 - 141

1. SPECIFICATIONS

Ceiling concealed (Fresh air intake type)

Model		PEFY-P125VMHS-E-F	PEFY-P200VMHS-E-F	PEFY-P250VMHS-E-F				
Power source		1-phase 220-230-240 V 50/60 Hz						
Cooling capacity (Nominal)	*1 kW	14.0	22.4	28.0				
	*1 kcal/h	12,000	19,300	24,100				
	*1 BTU/h	47,800	76,400	95,500				
	*2 Power input kW	0.220	0.260	0.350				
(220V)	*2 Current input A	1.43	1.66	2.16				
Temp. range of cooling		17°CDB./15.5°CWB. ~ 43°CDB./35°CWB. * Thermo-off (FAN-mode) automatically starts if the outdoor temperature is lower than 17°CDB.						
Heating capacity (Nominal)	*3 kW	8.9	13.9	17.4				
	*3 kcal/h	7,700	12,000	15,000				
	*3 BTU/h	30,400	47,400	59,400				
	*2 Power input kW	0.230	0.270	0.360				
(220V)	*2 Current input A	1.52	1.85	2.38				
Temp. range of heating		-10 °CDB. ~ 20 °CDB. * Thermo-off (FAN-mode) automatically starts if the outdoor temperature is higher than 20°CDB.						
External finish		Galvanized						
External dimension H x W x D		mm 380 x 1,195 x 900	470 x 1,250 x 1,120	470 x 1,250 x 1,120				
		in. 15 x 47-1/16 x 35-7/16	18-9/16 x 49-1/4 x 44-1/8	18-9/16 x 49-1/4 x 44-1/8				
Net weight		kg (lbs) 49 (109)	78 (172)	81 (179)				
Heat exchanger		Cross fin (Aluminum fin and copper tube)						
FAN		Sirocco fan x 1						
*4, *5	Type x Quantity	Sirocco fan x 2						
	External static press.	Pa <100> - <150> - 200 - <250> mmH ₂ O <10.2> - <15.3> - 20.4 - <25.5>						
Motor Type		DC motor						
Motor output		kW 0.244	0.375	0.375				
Driving mechanism		Inverter-control						
*4, *5	Air flow rate (Low-Mid-High)	Normal-airflow rate mode	<High-airflow rate mode>	Normal-airflow rate mode	<High-airflow rate mode>	Normal-airflow rate mode	<High-airflow rate mode>	
		m ³ /min	14.0 - 15.5 - 18.0	15.5 - 18.0 - 20.0	22.5 - 25.0 - 28.0	25.0 - 28.0 - 32.0	28.0 - 31.0 - 35.0	31.0 - 35.0 - 40.0
		L/s	233 - 258 - 300	258 - 300 - 333	375 - 417 - 467	417 - 467 - 533	467 - 517 - 583	517 - 583 - 667
		cfm	494 - 547 - 636	547 - 636 - 706	794 - 883 - 989	883 - 989 - 1,130	989 - 1,095 - 1,236	1,095 - 1,236 - 1,412
Sound pressure level (measured in anechoic room) (Low-Mid-High)		Normal-airflow rate mode	<High-airflow rate mode>	Normal-airflow rate mode	<High-airflow rate mode>	Normal-airflow rate mode	<High-airflow rate mode>	
*2 dB <A>		34-37-41	36-40-42	35-38-41	36-39-42	38-40-44	38-41-45	
Insulation material		EPS, Polyethylene foam, Urethane foam						
Air filter		Option: Synthetic fiber unwoven cloth filter (long life filter).						
Protection device		Fuse						
Refrigerant control device		LEV						
Connectable outdoor unit		R410A CITY MULTI						
Refrigerant piping diameter	Liquid (R410A)	mm (in.) 9.52 (3/8)Brazed	9.52 (3/8)Brazed	9.52 (3/8)Brazed				
	Gas (R410A)	mm (in.) 15.88 (5/8)Brazed	19.05 (3/4)Brazed	22.22 (7/8)Brazed				
Field drain pipe size		mm (in.) O.D.32 (1-1/4)	O.D.32 (1-1/4)	O.D.32 (1-1/4)				
Drawing	External	KL94L713	KL94L714	KL94L714				
	Wiring	KL94L765	KL94L766	KL94L766				
	Refrigerant cycle							
Standard attachment		Document Installation Manual, Instruction Book Accessory Insulation pipe for refrigerant pipe, Washer, Drain hose, Tie band						
Optional parts	Drain pump kit	PAC-DRP10DP-E2	PAC-KE06DM-F	PAC-KE06DM-F				
	Long life filter	PAC-KE89LAF	PAC-KE85LAF	PAC-KE85LAF				
	Filter box	PAC-KE140TB-F	PAC-KE250TB-F	PAC-KE250TB-F				
Remarks		* Details on foundation work, duct work, insulation work, electrical wiring, power source switch, and other items shall be referred to the Installation Manual. * Due to continuing improvement, above specifications may be subject to change without notice.						

Notes:	Unit converter
<p>1. Cooling capacity indicates the maximum value at operation under the following condition. Cooling: Indoor 33°CDB/28°CWB, Outdoor 33°CDB. The set temperature of the remote controller is 18°C.</p> <p>2. The value are measured at the factory setting of airflow mode and external static pressure.</p> <p>3. Heating capacity indicates the maximum value at operation under the following condition. Heating: Indoor 0°CDB/-2.9°CWB, Outdoor 0°CDB/-2.9°CWB. The set temperature of the remote controller is 25°C.</p> <p>4. The factory setting of airflow mode and external static pressure mode is shown without < >. Refer to "Fan characteristics curves", according to the external static pressure, in DATA BOOK for the usable range of air flow rate.</p> <p>5. If the airflow rate is over the usable range, dew drop can be caused from the air outlet and the air flow rate is changed automatically because of the output down by the fan motor control. If the air flow rate is less than the usable range, condensation from the unit surface can be caused.</p> <p>6. Regarding P250VMHS-E-F, the middle notch air flow rate is different from the spec value when the external static pressure setting is set to 100Pa. See "Fan characteristics curves" in DATA BOOK for the details.</p> <ul style="list-style-type: none"> Fresh air intake type indoor unit is designed to supply pretreated outside air into the room. Do not use to handle internal thermal load. The combination of fresh air intake type indoor units with other types of indoor units to handle internal thermal load which may cause the conflict of operation mode. It is not recommended when fresh air intake type indoor unit is connected to the Y or WY series. Depending on the air conditioning load, outside temperature, and due to the activation of protection functions, the desired preset temperature may not always be achieved and the outlet air temperature may swing. Note that untreated outside air may be delivered directly into the room upon the activation of protection functions. Fresh air intake type indoor units cannot be connected to PUMY and cannot be connected to an outdoor unit together with PWFY series. The maximum connectable indoor units to 1 outdoor unit are 110% (100% in case of heating below-5°C). When fresh air intake type indoor units connect to an outdoor unit together with other types of indoor unit, the total capacity of fresh air intake type indoor units needs to be 30% or less of the connected outdoor unit capacity. The AUTO mode on the local remote controller is available only when fresh air intake type indoor unit is connected to the R2 or WR2 series of outdoor unit. The system changeover function is available only when all the connected indoor units are fresh air intake type indoor units. The fan temporarily stops during defrost. The cooling and heating capacities are the maximum capacities that were obtained by operating in the above air conditions and with a refrigerant pipe of about 7.5m and a level difference of 0m. The actual capacity characteristics vary with the combination of indoor and outdoor units. See the technical information in DATA BOOK for the details. Thermo off (Fan) operation automatically starts either when temperature is lower than 17°CDB in cooling mode or when the temperature exceeds 20°CDB in heating mode. Dry mode is not available. When this unit is used as sole A/C system, be careful about the dew in air outlet grilles in cooling mode. Un-conditioned outdoor air such as humid air or cold air blows to the indoor during thermo off operation. Please be careful when positioning indoor unit air outlet grilles, ie take the necessary precautions for cold air, and also insulate rooms for dew condensation prevention as required. Air filter must be installed in the air intake side. The filter should be attached where easy maintenance is possible in case of usage of field supply filters. 	<p>kcal =kW x 860</p> <p>BTU/h =kW x 3,412</p> <p>cfm =m³/min x 35.31</p> <p>lbs =kg/0.4536</p> <p>*Above specification data is subject to rounding variation.</p>

PEFY-P- VMHS-E-F

PEFY-P125VMHS-E-F

Unit: mm

- [Maintenance access space]
 Secure enough access space to allow for the maintenance, inspection, and replacement of the motor, fan, heat exchanger, drain pan and control box in one of the following ways.
 Select an installation site for the indoor unit so that its maintenance access space will not be obstructed by beam or other objects.
- Create access door 1 (450×450mm) for the maintenance from the unit side when the thermostat, LEV and control box is exchanged. (Fig.2,4)
- (1) When a space of 300mm or more is available below the unit between the unit and the ceiling.
 Create access door 2 (600×600mm) for the maintenance from the bottom when the motor, fan, heat exchanger and drain pan is cleaned (exchanged). (Fig.2)
- (2) When a space of less than 300mm is available below the unit between the unit and the ceiling.
 (At least 20mm of space should be left below the unit as shown in Fig.3.)
 Create access door 3 for the maintenance from the bottom when the motor, fan, heat exchanger and drain pan is cleaned (exchanged). (Fig.4)

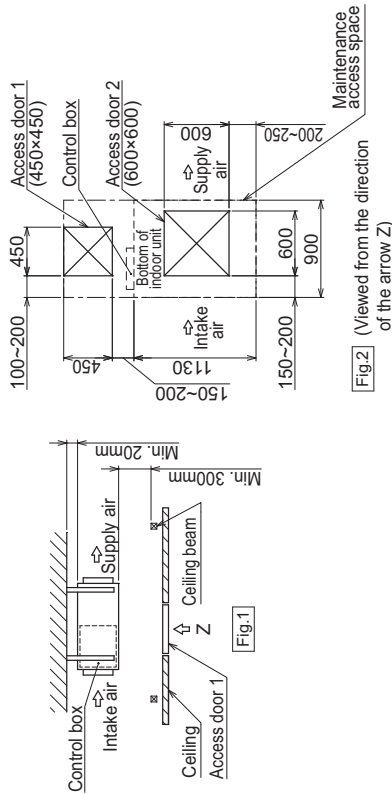

[Fig.2] (Viewed from the direction of the arrow Z)

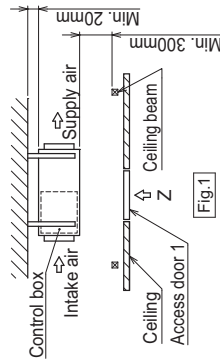

[Fig.1]

[Fig.3]

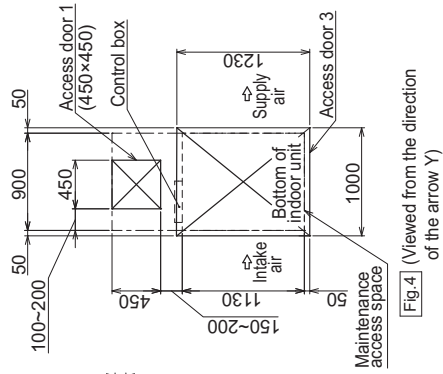

[Fig.4] (Viewed from the direction of the arrow Y)

2. EXTERNAL DIMENSIONS

Ceiling concealed (Fresh air intake type)

PEFY-P200, 250VMHS-E-F

Unit: mm

- Note 1. Use an M10 screw for the suspension bolt (field supply).
 2. Make sure to install the air filter (field supply) on the air intake side.
 In case field supplied air filter is used, attach it where the filter service is easily done.

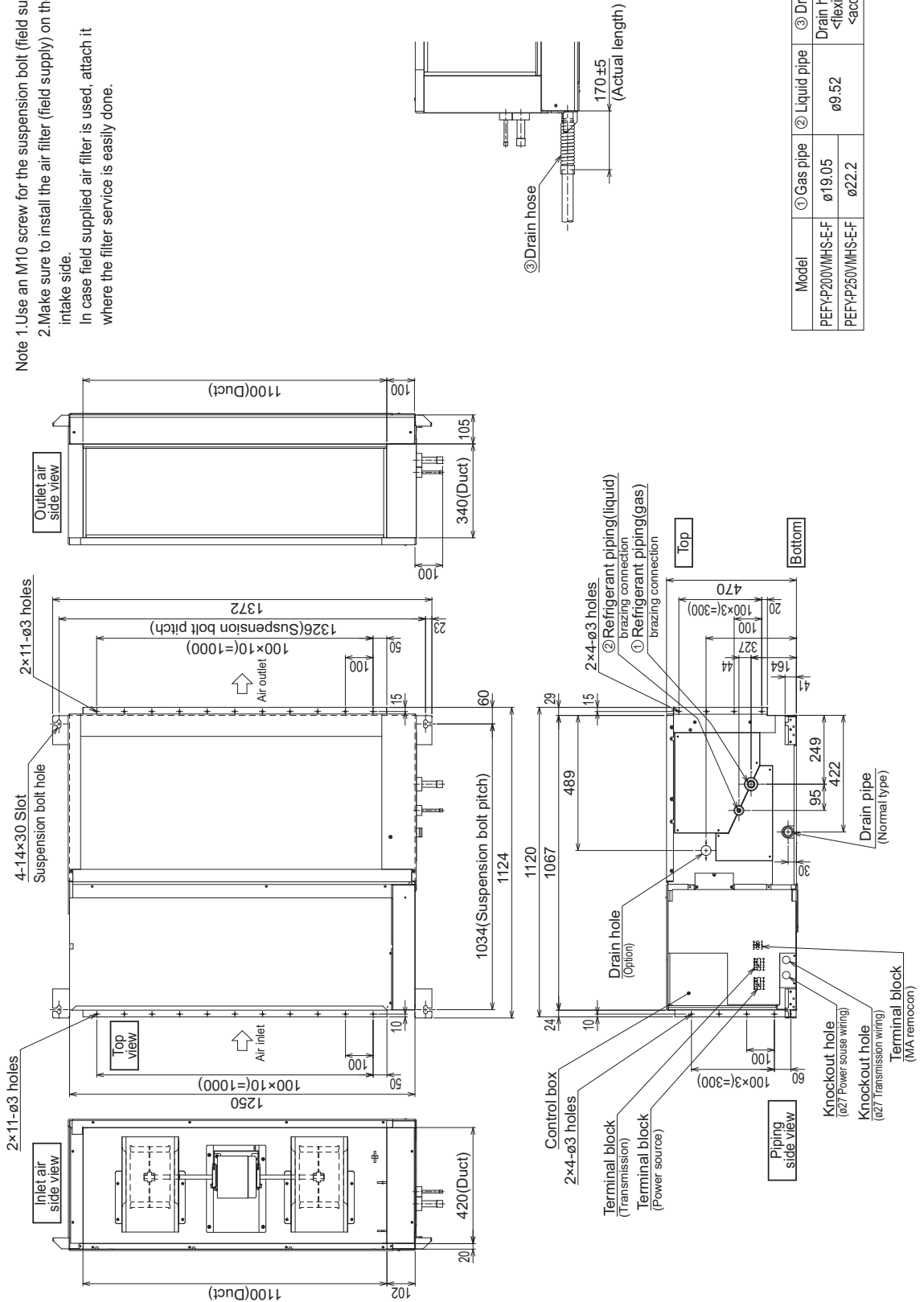

Model	① Gas pipe	② Liquid pipe	③ Drain hose
PEFY-P200VMHS-E-F	ø19.05	ø9.52	Drain hose 32mm <flexible joint>
PEFY-P250VMHS-E-F	ø22.2	ø9.52	<accessory>

PEFY-P-VMHS-E-F

PEFY-P200, 250VMHS-E-F

Unit: mm

[Maintenance access space]

Secure enough access space to allow for the maintenance, inspection, and replacement of the motor, fan, heat exchanger, drain pan and control box in one of the following ways.
 Select an installation site for the indoor unit so that its maintenance access space will not be obstructed by beam or other objects.

Create access door 1 (450×450mm) for the maintenance from the unit side when the thermistor, LEV and control box is exchanged. (Fig.2,4)

- (1) When a space of 500mm or more is available below the unit between the unit and the ceiling.
 Create access door 2 (600×600mm) for the maintenance from the bottom when the motor, fan, heat exchanger and drain pan is cleaned(exchanged). (Fig.2)
- (2) When a space of less than 500mm is available below the unit between the unit and the ceiling.
 (At least 20mm of space should be left below the unit as shown in Fig.3.)
 Create access door 3 for the maintenance from the bottom when the motor, fan, heat exchanger and drain pan is cleaned(exchanged). (Fig.4)

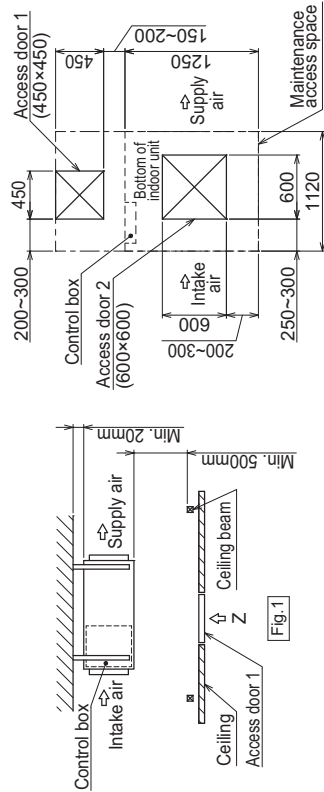

[Fig.2] (Viewed from the direction of the arrow Z)

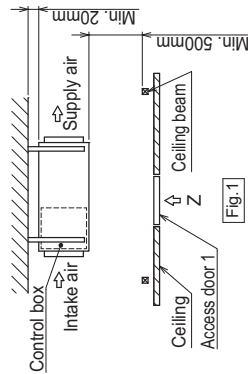

[Fig.1]

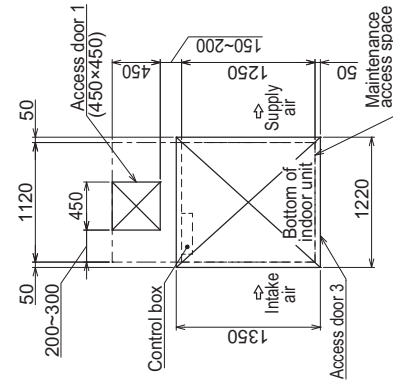

[Fig.4] (Viewed from the direction of the arrow Y)

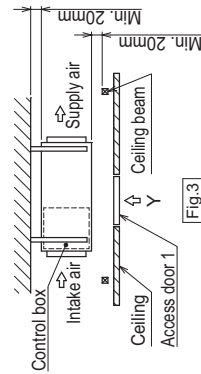

[Fig.3]

PEFY-P125, 200, 250VMHS-E-F

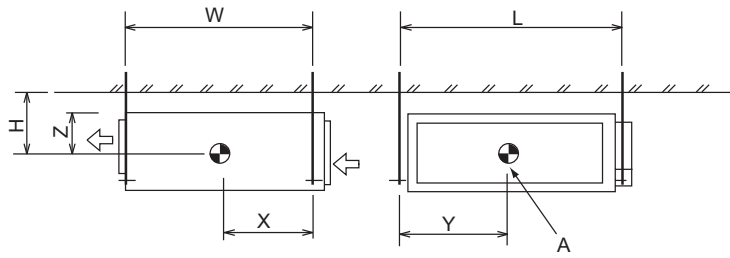

A: Center of gravity

(mm)[in]

Model name	W	L	H	X	Y	Z
PEFY-P125VMHS-E-F	814 [32-1/16]	1204 [47-13/32]	210 [8-9/32]	364 [14-11/32]	649 [25-9/16]	190 [7-1/2]
PEFY-P200VMHS-E-F	1034 [40-23/32]	1326 [52-7/32]	255 [10-1/16]	462 [18-7/32]	660 [25-32/32]	235 [9-9/32]
PEFY-P250VMHS-E-F	1034 [40-23/32]	1326 [52-7/32]	255 [10-1/16]	462 [18-7/32]	660 [25-32/32]	235 [9-9/32]

PEFY-P-VMHS-E-F

PEFY-P-125VMHS-E-F

PEFY-P- VMHS-E-F

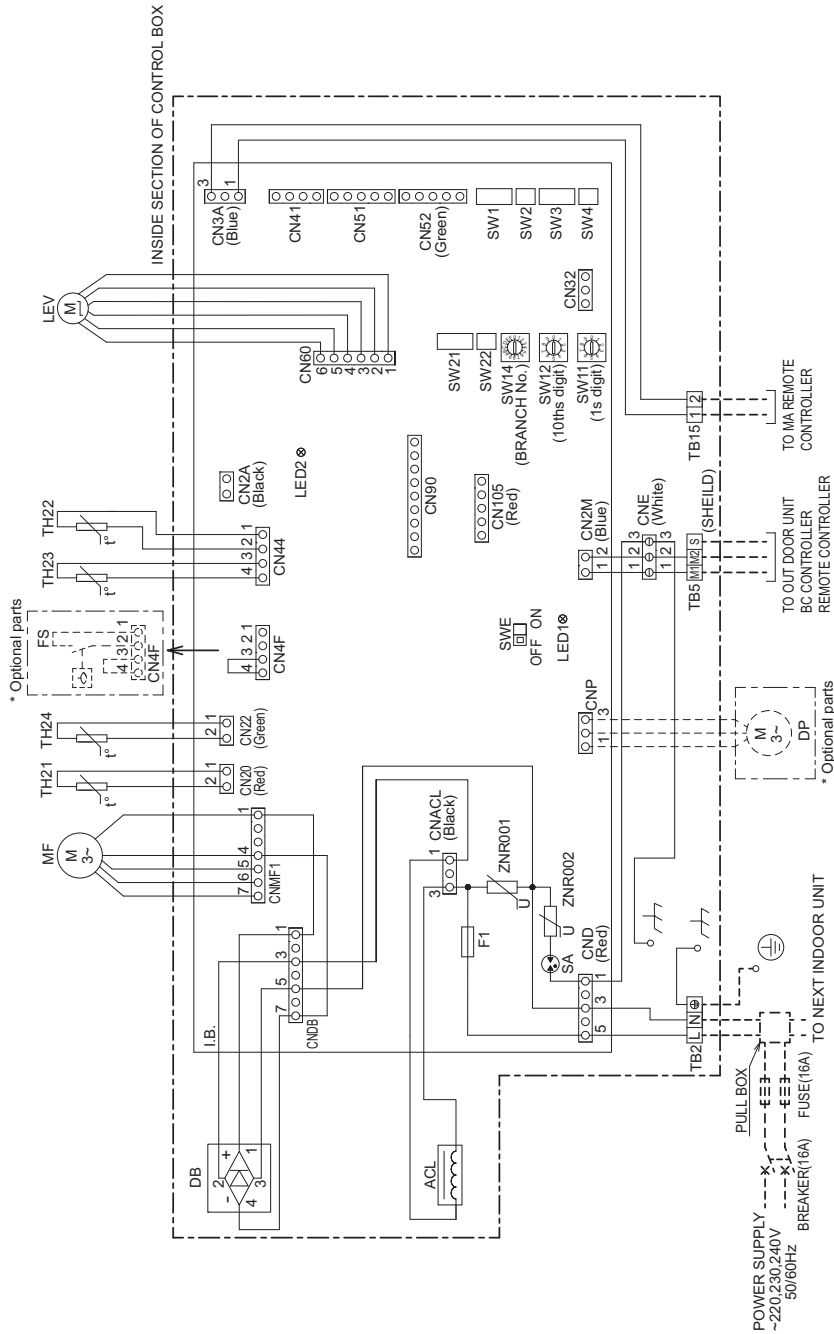

NOTE 1) Since the outdoor side electric wiring may change be sure to check the outdoor unit electric wiring for servicing.

2. Symbols used in wiring diagram are

○ ○ ○ ○ : Connector, □ : Terminal,

----- (Heavy dotted line): Field wiring,

----- (Thin dotted line): Optional parts.

3. Have all electric work done by a licensed electrician according to the local regulations.

4. Earth leakage circuit breaker should be set up on the wiring of the power supply.

5. To perform a drainage test for the drain pump turn on the SWE on the control board while the indoor unit is being powered.

* Be sure to turn off the SWE after completing a drainage test or test run.

SYMBOL EXPLANATION

SYMBOL	NAME	SYMBOL	NAME	SYMBOL	NAME
ACL	AC reactor(Power factor improvement)	I.B.	Indoor controller board	SW3	Indoor controller board
DB	Diode Bridge	SA	Arrester	SW4	Switch (for model selection)
DP	Drain Pump	F1	Fuse AC250V 6.3A	SW11	Switch (for static pressure set)
FS	Float switch	ZNR001/002	Varistor	SW12	Switch (10ths digit address set)
MF	Fan Motor	CN2A	Connector (0-10V Analog input)	SW14	Switch (BRANCH No.)
LEV	Electrical linear expansion valve	CN32	Connector (Remote switch)	SW21	Switch (for static pressure selection)
TB2	Power source terminal block	CN41	Connector (HA terminal-A)	SW22	Switch (Wireless pair No.)
TB5	Transmission terminal block	CN51	Connector (Centrally control)	SWE	Connector (emergency operation)
TH21	Thermistor (blowing air temp. detection)	CN52	Connector (Remote indication)	LED1	LED(Power supply)
TH22	Thermistor (piping temp.detection/liquid)	CN90	Connector (Wireless)	LED2	LED(Remote controller supply)
TH23	Thermistor (piping temp.detection/gas)	CN105	Connector (IT terminal)		
TH24	Thermistor (outdoor air temp. detection)	SW1	Switch (for mode selection)		
		SW2	Switch (for capacity code)		

PEFY-P200, 250VMHS-E-F

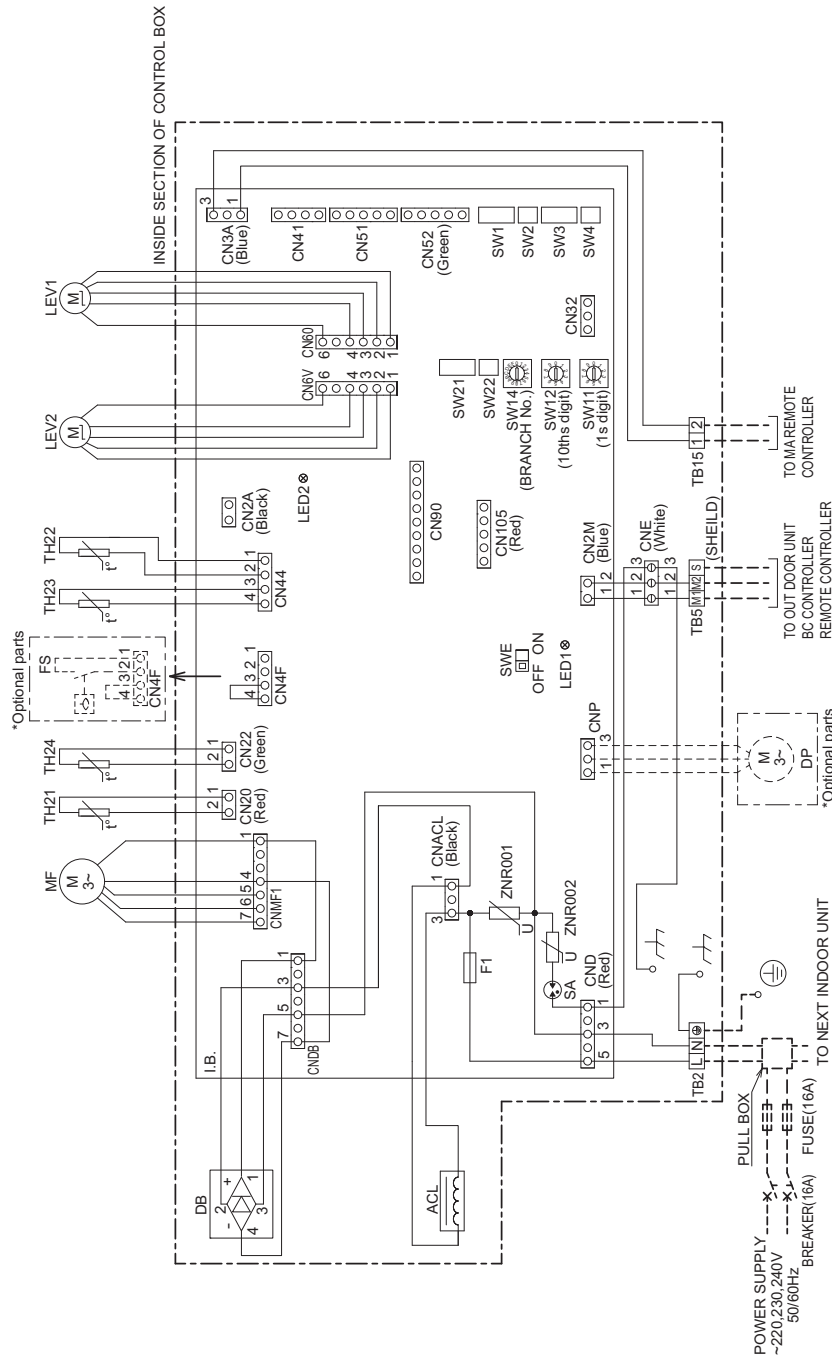

NOTE)1. Since the outdoor side electric wiring may change be sure to check the outdoor unit electric wiring for servicing.

2. Symbols used in wiring diagram are

- ○ ○ ○ : Connector □ : Terminal
- (Heavy dotted line) : Field wiring
- (Thin dotted line) : Optional parts

3. Have all electric work done by a licensed electrician according to the local regulations.

4. Earth leakage circuit breaker should be set up on the wiring of the power supply.

5. To perform a drainage test for the drain pump turn on the SWE on the control board while the indoor unit is being powered.

* Be sure to turn off the SWE after completing a drainage test or test run.

SYMBOL EXPLANATION

SYMBOL	NAME	SYMBOL	NAME	SYMBOL	NAME
ACL	AC reactor(Power factor improvement)	I.B.	Indoor controller board	SW3	Switch (for mode selection)
DB	Diode Bridge	F1	Arrester	SW4	Switch (for model selection)
DP	Drain Pump	ZNR001.002	Varistor	SW11	Switch (1s digit address set)
FS	Float switch	CN2A	Connector (0-10V Analog Input)	SW12	Switch (10ths digit address set)
MF	Fan Motor	CN32	Connector (Remote switch)	SW14	Switch (BRANCH No.)
LEV1/LEV2	Electrical linear expansion valve	CN41	Connector (HA terminal-A)	SW21	Switch (for static pressure selection)
TB2	Power source terminal block	CN51	Connector (Centrally control)	SW22	Switch (Wireless pair No.)
TB5	Transmission terminal block	CN52	Connector (Remote indication)	SWE	Connector (emergency operation)
TB15	Transmission terminal block	CN90	Connector (Wireless)	LED1	LED(Power supply)
TH21	Thermistor (blowing air temp. detection)	CN105	Connector (IT terminal)	LED2	LED(Remote controller supply)
TH22	Thermistor (piping temp. detection(liquid))	SW1	Switch (for mode selection)		
TH23	Thermistor (piping temp. detection(gas))	SW2	Switch (for capacity code)		
TH24	Thermistor (outdoor air temp. detection)				

5-1. Sound levels

PEFY-P-VMHS-E-F

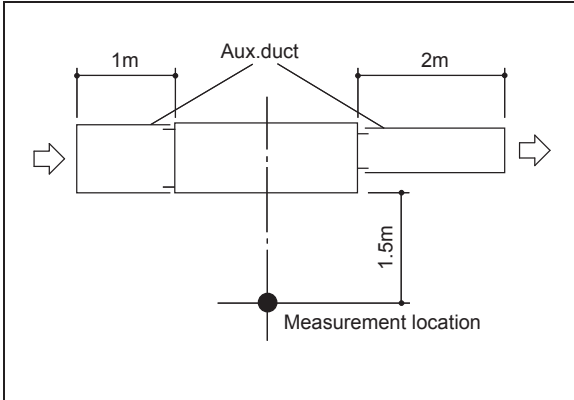

*Measured in anechoic room.

Sound level at anechoic room: Low-Mid-High

		Sound level dB (A)			
		100Pa	150Pa	200Pa	250Pa
PEFY-P125VMHS-E-F	Normal-airflow rate mode	31-34-37	34-36-39	34-37-41	37-40-43
	High-airflow rate mode	32-36-38	35-38-40	36-40-42	37-41-44
PEFY-P200VMHS-E-F	Normal-airflow rate mode	31-33-36	33-36-39	35-38-41	38-41-43
	High-airflow rate mode	31-34-37	34-36-40	36-39-42	38-41-44
PEFY-P250VMHS-E-F	Normal-airflow rate mode	34-35-39	36-38-41	38-40-44	40-43-45
	High-airflow rate mode	34-39-41	36-39-42	38-41-45	40-43-46

PEFY-P- VMHS-E-F

5-2. NC curves in normal-airflow rate mode

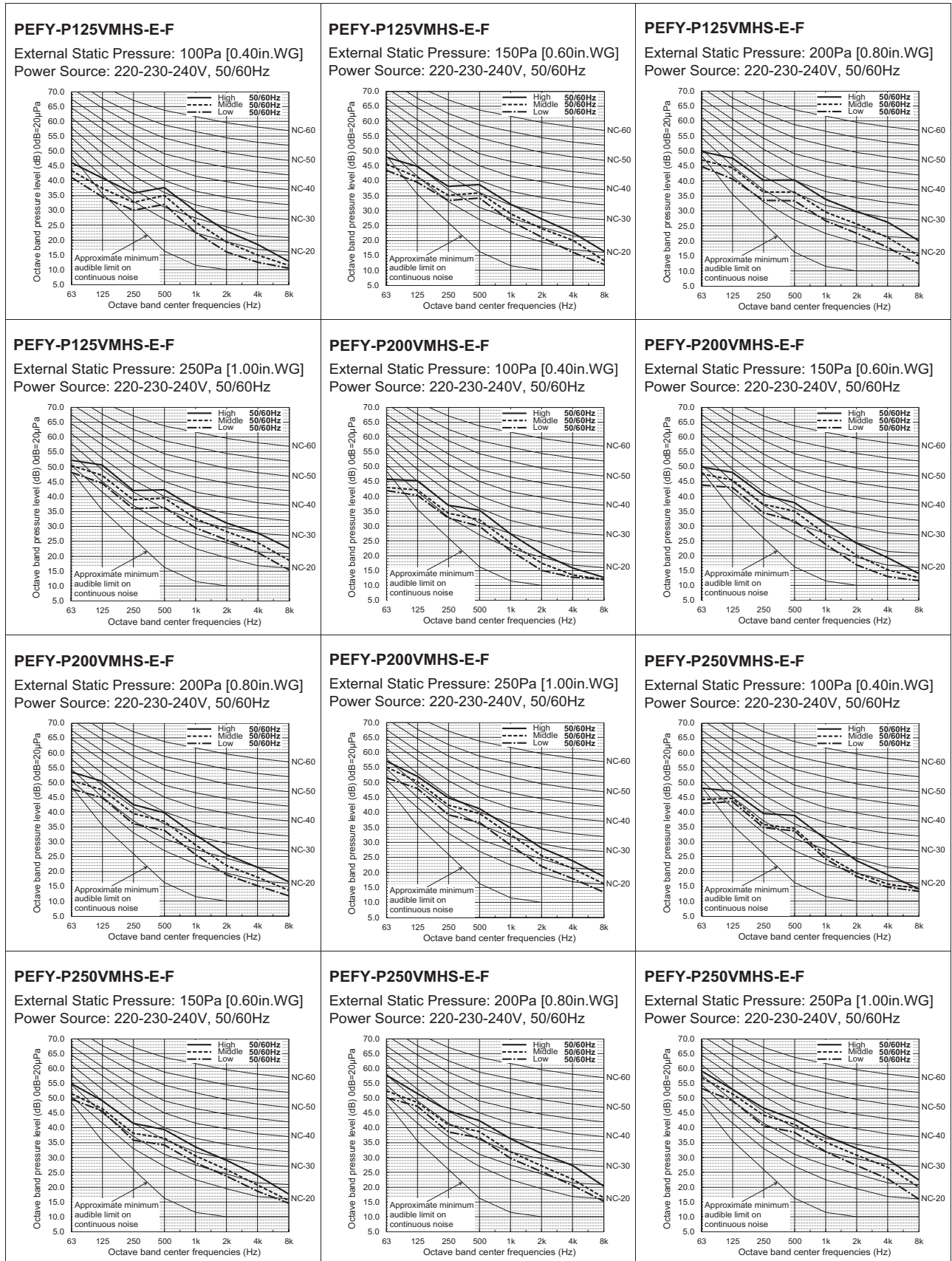

PEFY-P-VMHS-E-F

5-3. NC curves in high-airflow rate mode

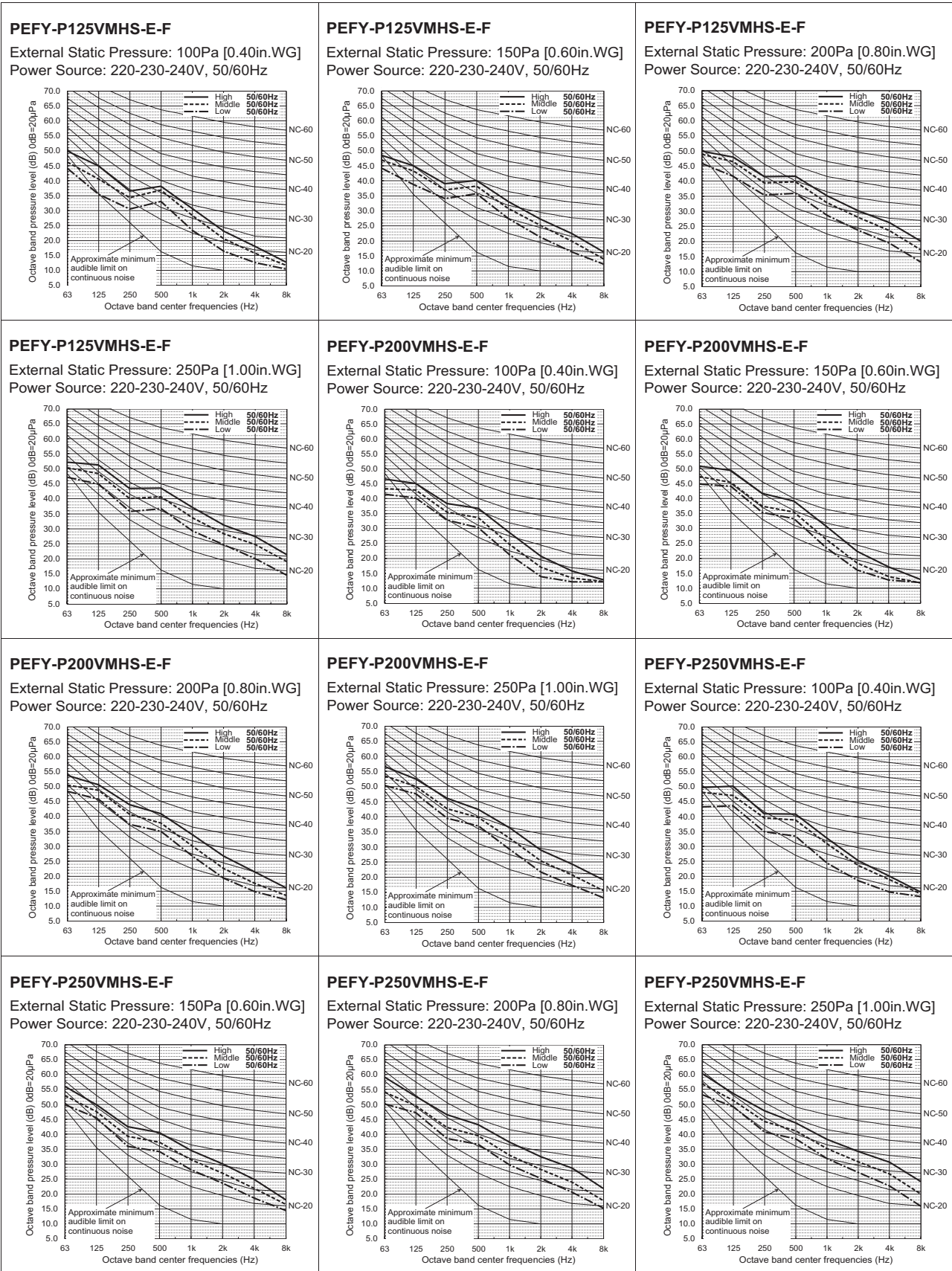

PEFY-P- VMHS-E-F

6-1. Fan characteristics curves in normal-airflow rate mode

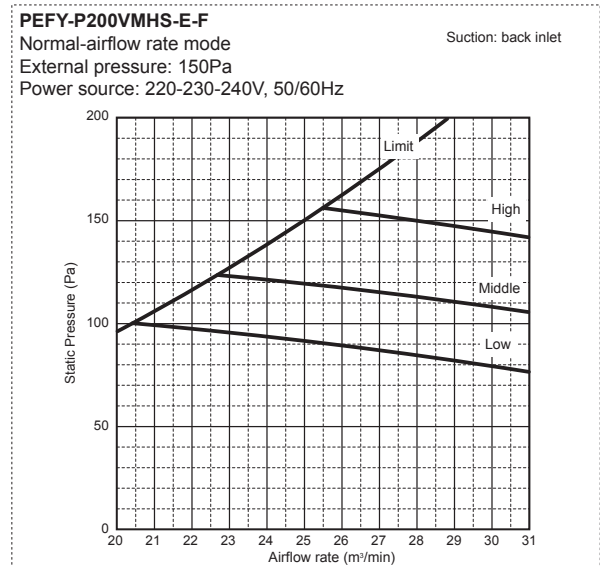
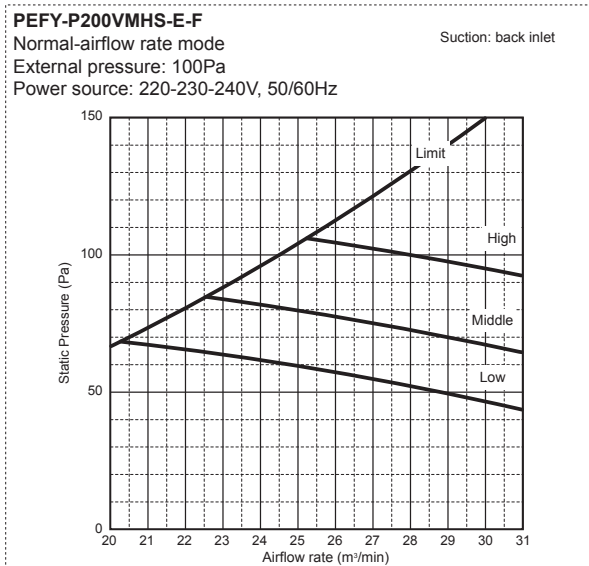
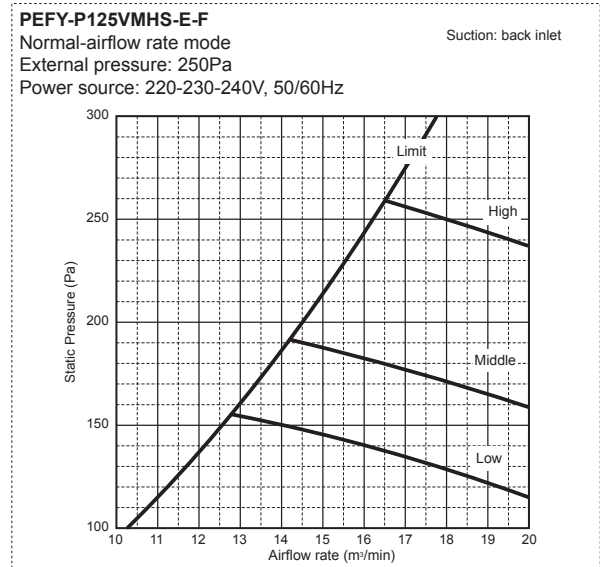
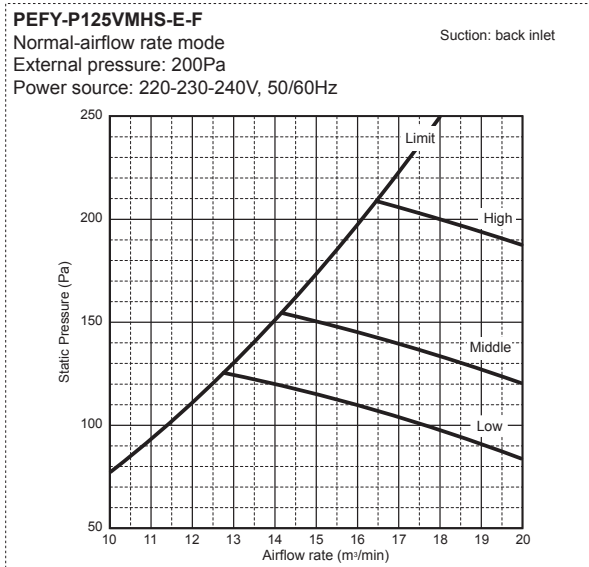
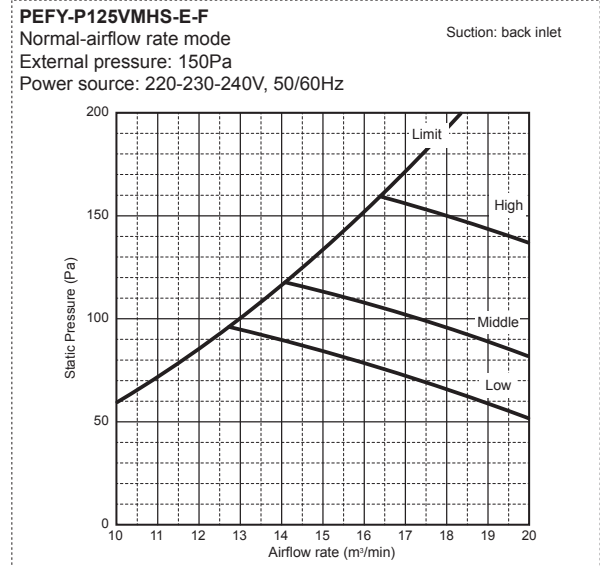
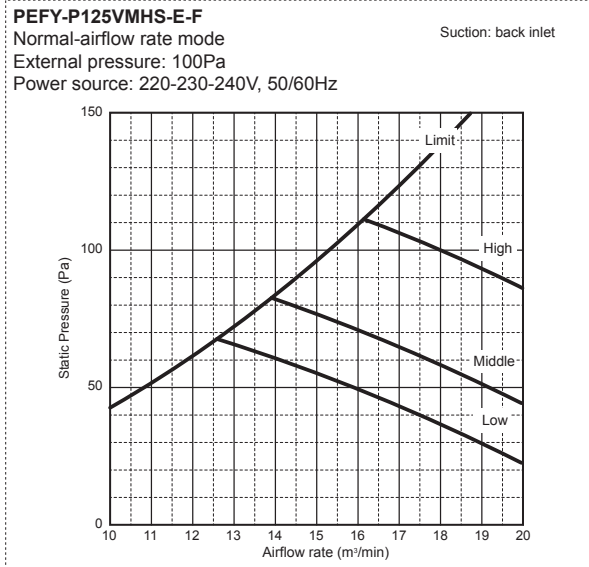

PEFY-P-VMHS-E-F

PEFY-P- VMHS-E-F

PEFY-P200VMHS-E-F
 Normal-airflow rate mode
 External pressure: 200Pa
 Power source: 220-230-240V, 50/60Hz
 Suction: back inlet

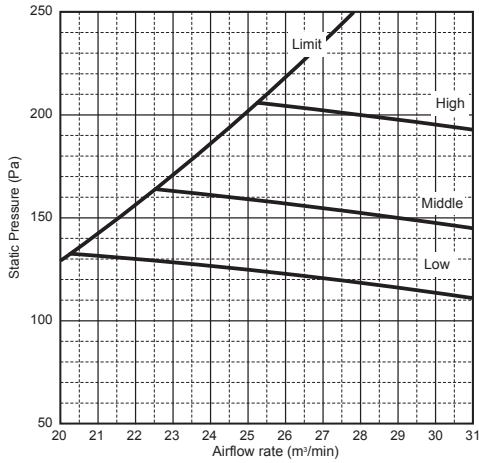

PEFY-P200VMHS-E-F
 Normal-airflow rate mode
 External pressure: 250Pa
 Power source: 220-230-240V, 50/60Hz
 Suction: back inlet

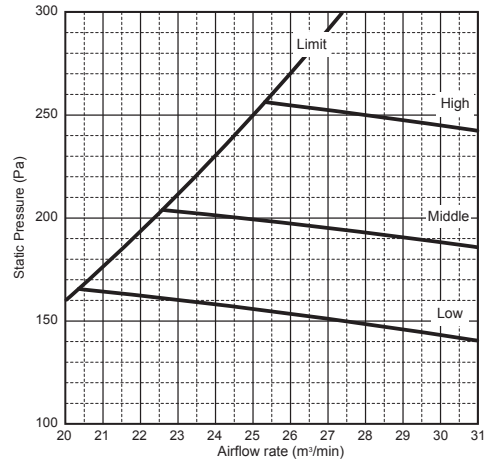

PEFY-P250VMHS-E-F
 Normal-airflow rate mode
 External pressure: 100Pa
 Power source: 220-230-240V, 50/60Hz
 Suction: back inlet

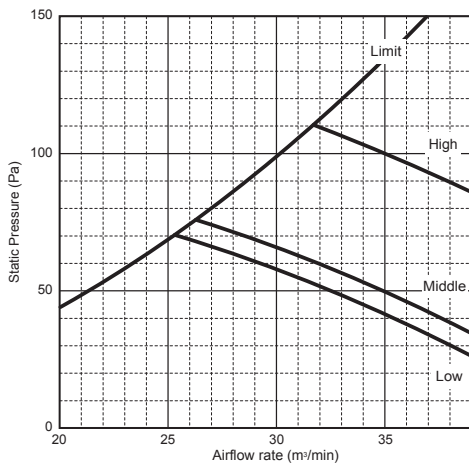

PEFY-P250VMHS-E-F
 Normal-airflow rate mode
 External pressure: 150Pa
 Power source: 220-230-240V, 50/60Hz
 Suction: back inlet

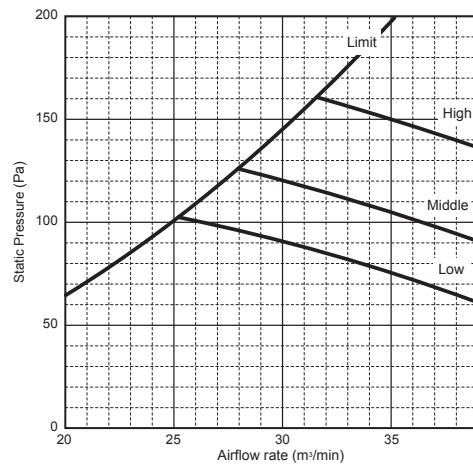

PEFY-P250VMHS-E-F
 Normal-airflow rate mode
 External pressure: 200Pa
 Power source: 220-230-240V, 50/60Hz
 Suction: back inlet

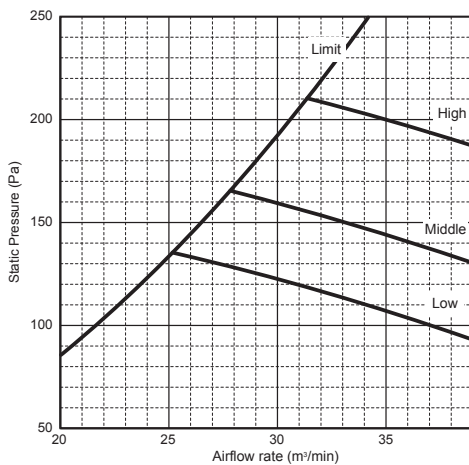

PEFY-P250VMHS-E-F
 Normal-airflow rate mode
 External pressure: 250Pa
 Power source: 220-230-240V, 50/60Hz
 Suction: back inlet

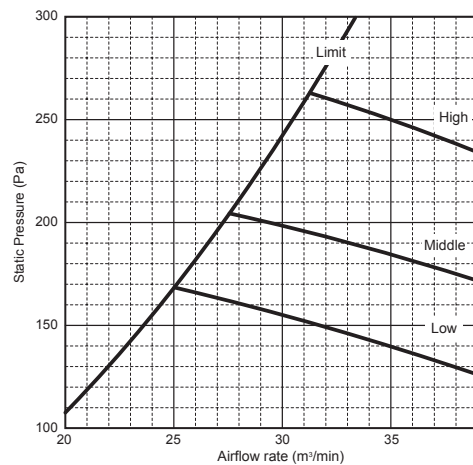

6-2. Fan characteristics curves in high-airflow rate mode

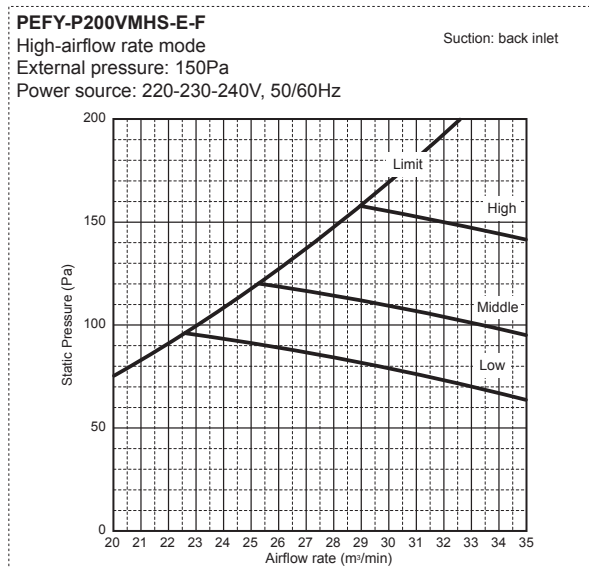
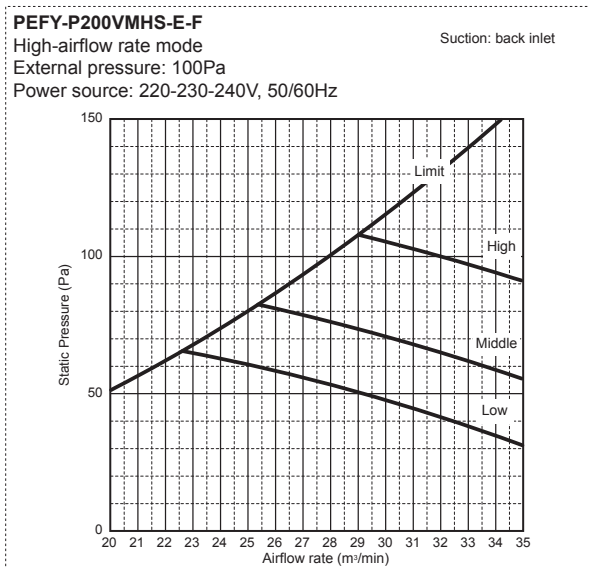
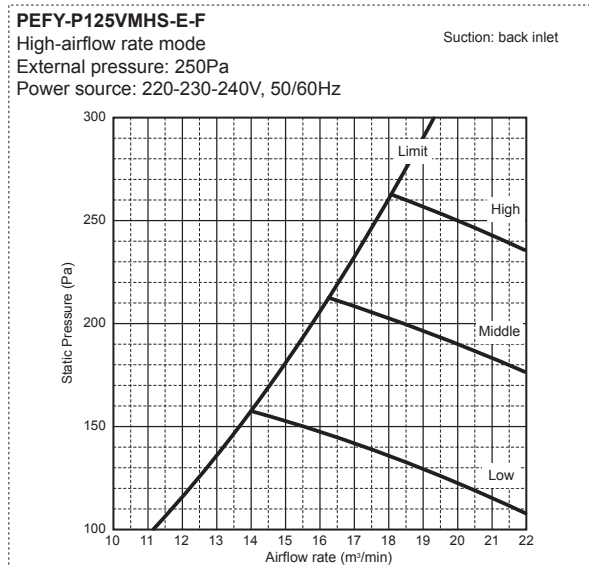
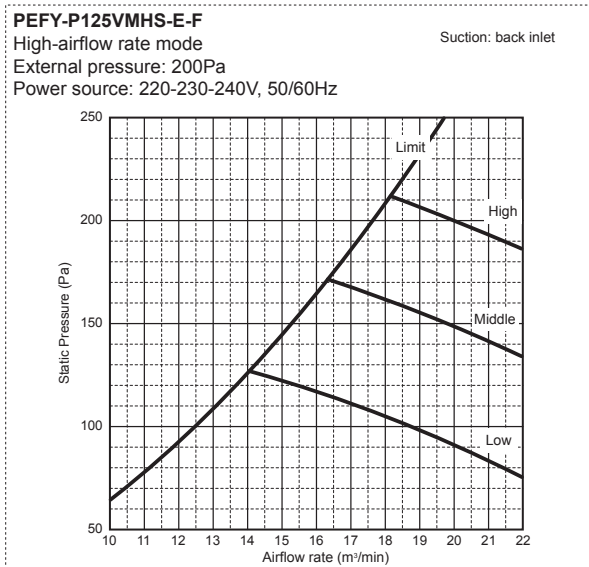
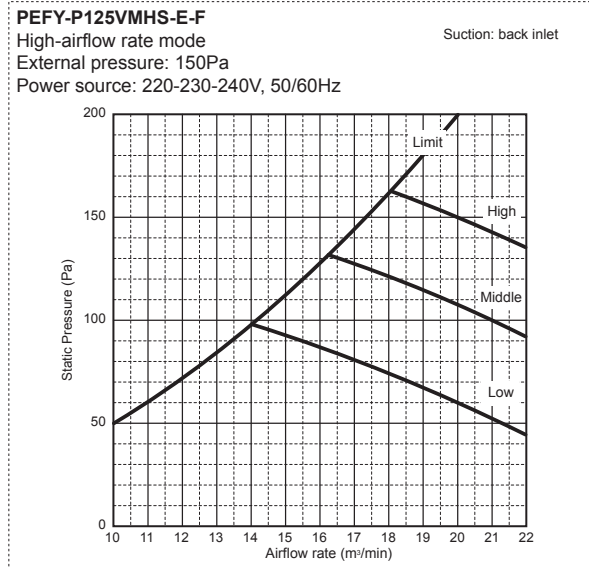
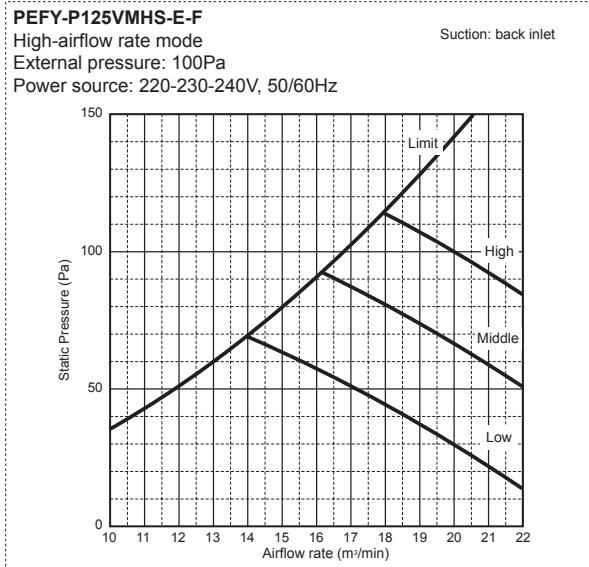

PEFY-P-VMHS-E-F

PEFY-P- VMHS-E-F

PEFY-P200VMHS-E-F
 High-airflow rate mode
 External pressure: 200Pa
 Power source: 220-230-240V, 50/60Hz
 Suction: back inlet

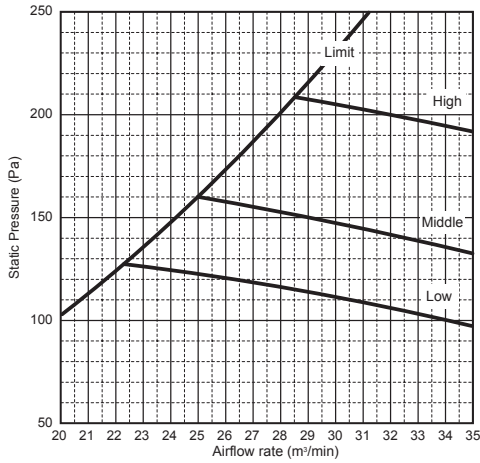

PEFY-P200VMHS-E-F
 High-airflow rate mode
 External pressure: 250Pa
 Power source: 220-230-240V, 50/60Hz
 Suction: back inlet

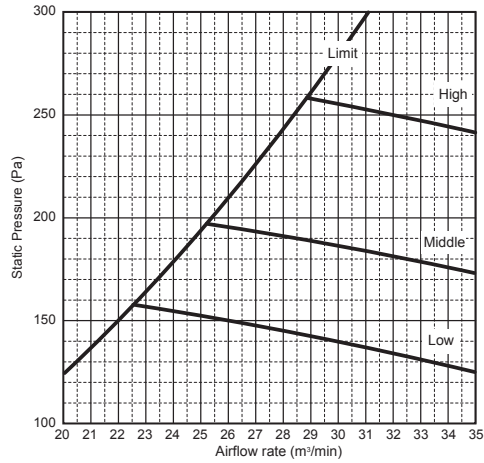

PEFY-P250VMHS-E-F
 High-airflow rate mode
 External pressure: 100Pa
 Power source: 220-230-240V, 50/60Hz
 Suction: back inlet

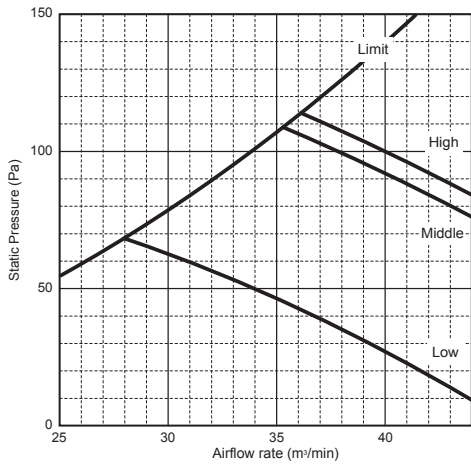

PEFY-P250VMHS-E-F
 High-airflow rate mode
 External pressure: 150Pa
 Power source: 220-230-240V, 50/60Hz
 Suction: back inlet

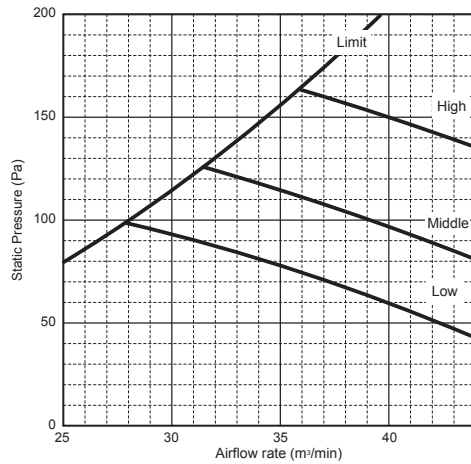

PEFY-P250VMHS-E-F
 High-airflow rate mode
 External pressure: 200Pa
 Power source: 220-230-240V, 50/60Hz
 Suction: back inlet

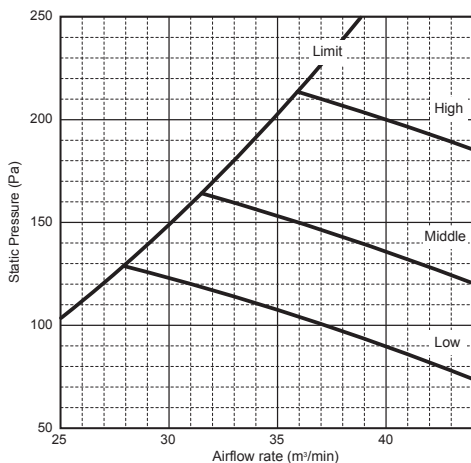

PEFY-P250VMHS-E-F
 High-airflow rate mode
 External pressure: 250Pa
 Power source: 220-230-240V, 50/60Hz
 Suction: back inlet

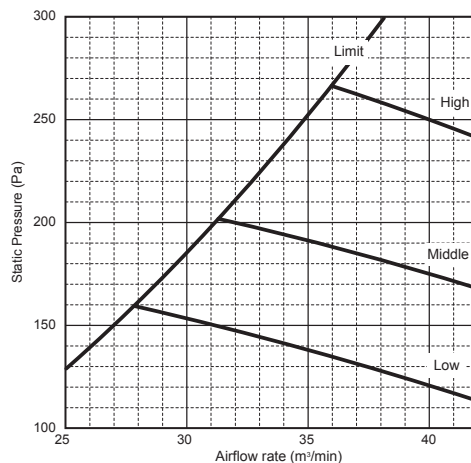

7. CAPACITY TABLES

Ceiling concealed (Fresh air intake type)

7-1. Cooling capacity

PEFY-P125VMHS-E-F

CA: Capacity (kW), SHC: Sensible Heat Capacity (kW)

Outdoor air temp.		59°FWB		63°FWB		68°FWB		73°FWB		79°FWB		82°FWB		86°FWB		90°FWB		95°FWB	
		15°CWB		17°CWB		20°CWB		23°CWB		26°CWB		28°CWB		30°CWB		32°CWB		35°CWB	
°FDB	°CDB	CA	SHC	CA	SHC	CA	SHC	CA	SHC	CA	SHC	CA	SHC	CA	SHC	CA	SHC	CA	SHC
70	21	6.8	4.9	8.2	4.6	-	-	-	-	-	-	-	-	-	-	-	-	-	-
73	23	6.8	5.5	8.1	5.3	10.1	4.7	-	-	-	-	-	-	-	-	-	-	-	-
77	25	6.8	6.2	8.1	6.0	10.1	5.3	-	-	-	-	-	-	-	-	-	-	-	-
81	27	-	-	8.1	6.6	10.0	6.0	11.7	5.3	-	-	-	-	-	-	-	-	-	-
84	29	-	-	-	-	9.9	6.6	11.6	5.9	13.3	4.9	-	-	-	-	-	-	-	-
88	31	-	-	-	-	9.8	7.2	11.6	6.4	13.1	5.5	14.2	4.8	-	-	-	-	-	-
91	33	-	-	-	-	-	-	11.4	7.0	13.0	6.1	14.0	5.4	15.0	4.6	-	-	-	-
95	35	-	-	-	-	-	-	11.3	7.6	12.8	6.7	13.8	6.0	14.8	5.3	-	-	-	-
99	37	-	-	-	-	-	-	-	-	12.7	7.3	13.7	6.6	14.5	5.8	15.5	5.0	-	-
104	40	-	-	-	-	-	-	-	-	12.4	8.1	13.3	7.4	14.3	6.7	15.1	5.9	16.4	4.6

PEFY-P200VMHS-E-F

Outdoor air temp.		59°FWB		63°FWB		68°FWB		73°FWB		79°FWB		82°FWB		86°FWB		90°FWB		95°FWB	
		15°CWB		17°CWB		20°CWB		23°CWB		26°CWB		28°CWB		30°CWB		32°CWB		35°CWB	
°FDB	°CDB	CA	SHC	CA	SHC	CA	SHC	CA	SHC	CA	SHC	CA	SHC	CA	SHC	CA	SHC	CA	SHC
70	21	10.9	7.9	13.1	7.5	-	-	-	-	-	-	-	-	-	-	-	-	-	-
73	23	11.0	9.0	13.1	8.5	16.1	7.6	-	-	-	-	-	-	-	-	-	-	-	-
77	25	11.0	10.1	13.0	9.6	16.0	8.6	-	-	-	-	-	-	-	-	-	-	-	-
81	27	-	-	13.0	10.7	15.9	9.7	18.8	8.4	-	-	-	-	-	-	-	-	-	-
84	29	-	-	-	-	15.8	10.7	18.6	9.4	21.2	7.9	-	-	-	-	-	-	-	-
88	31	-	-	-	-	15.7	11.7	18.4	10.4	21.0	8.9	22.6	7.7	-	-	-	-	-	-
91	33	-	-	-	-	-	-	18.2	11.4	20.7	9.8	22.4	8.7	23.9	7.5	-	-	-	-
95	35	-	-	-	-	-	-	18.0	12.4	20.5	10.8	22.1	9.6	23.6	8.4	-	-	-	-
99	37	-	-	-	-	-	-	-	-	20.2	11.8	21.8	10.6	23.3	9.4	24.7	8.1	-	-
104	40	-	-	-	-	-	-	-	-	19.8	13.2	21.3	12.0	22.8	10.8	24.2	9.5	26.2	7.47

PEFY-P250VMHS-E-F

Outdoor air temp.		59°FWB		63°FWB		68°FWB		73°FWB		79°FWB		82°FWB		86°FWB		90°FWB		95°FWB	
		15°CWB		17°CWB		20°CWB		23°CWB		26°CWB		28°CWB		30°CWB		32°CWB		35°CWB	
°FDB	°CDB	CA	SHC	CA	SHC	CA	SHC	CA	SHC	CA	SHC	CA	SHC	CA	SHC	CA	SHC	CA	SHC
70	21	13.7	9.9	16.4	9.3	-	-	-	-	-	-	-	-	-	-	-	-	-	-
73	23	13.7	11.3	16.3	10.7	20.2	9.5	-	-	-	-	-	-	-	-	-	-	-	-
77	25	13.7	12.6	16.3	12.0	20.1	10.8	-	-	-	-	-	-	-	-	-	-	-	-
81	27	-	-	16.2	13.3	19.9	12.1	23.4	10.5	-	-	-	-	-	-	-	-	-	-
84	29	-	-	-	-	19.8	13.4	23.2	11.7	26.5	9.8	-	-	-	-	-	-	-	-
88	31	-	-	-	-	19.6	14.7	23.0	13.0	26.2	11.1	28.3	9.7	-	-	-	-	-	-
91	33	-	-	-	-	-	-	22.8	14.2	25.9	12.3	28.0	10.9	29.9	9.3	-	-	-	-
95	35	-	-	-	-	-	-	22.5	15.5	25.6	13.5	27.6	12.1	29.5	10.5	-	-	-	-
99	37	-	-	-	-	-	-	-	-	25.3	14.7	27.2	13.3	29.1	11.7	30.9	10.1	-	-
104	40	-	-	-	-	-	-	-	-	24.8	16.5	26.6	15.0	28.4	13.5	30.2	11.9	32.7	9.34

There are times when the cooling capacity is lowered to protect the compressor in cases where the outdoor air temperature exceeds 40°C (104°F)

- ◆The capacity table shows the maximum capacities of the indoor units at High speed setting and when the total capacity of the indoor units is 100% of the outdoor unit capacity. The actual capacity may vary, depending on the outlet air temperature setting on the remote controller.
- ◆Depending on the air conditioning load, outside temperature, and due to the activation of protection functions, the desired preset temperature may not always be achieved and the outlet air temperature may swing. Note that untreated outside air may be delivered directly into the room upon the activation of protection functions.

PEFY-P-VMHS-E-F

7-2. Outlet air temp. cooled

PEFY-P125VMHS-E-F

Outdoor air temp.		59°F FWB		63°F FWB		68°F FWB		73°F FWB		79°F FWB		82°F FWB		86°F FWB		90°F FWB		95°F FWB	
		15°C CWB		17°C CWB		20°C CWB		23°C CWB		26°C CWB		28°C CWB		30°C CWB		32°C CWB		35°C CWB	
°F DB	°C DB	°C DB	°C CWB	°C DB	°C CWB	°C DB	°C CWB	°C DB	°C CWB	°C DB	°C CWB	°C DB	°C CWB	°C DB	°C CWB	°C DB	°C CWB	°C DB	°C CWB
70	21	8.1	8.1	8.8	8.8	-	-	-	-	-	-	-	-	-	-	-	-	-	-
73	23	8.4	8.4	9.1	9.1	10.5	10.5	-	-	-	-	-	-	-	-	-	-	-	-
77	25	8.7	8.6	9.4	9.3	10.8	10.8	-	-	-	-	-	-	-	-	-	-	-	-
81	27	-	-	9.7	9.6	11.2	11.2	13.1	13.1	-	-	-	-	-	-	-	-	-	-
84	29	-	-	-	-	11.5	11.5	13.4	13.4	15.8	15.8	-	-	-	-	-	-	-	-
88	31	-	-	-	-	11.8	11.8	13.9	13.8	16.1	16.1	18.0	18.0	-	-	-	-	-	-
91	33	-	-	-	-	-	-	14.2	14.2	16.6	16.6	18.3	18.3	20.2	20.2	-	-	-	-
95	35	-	-	-	-	-	-	14.6	14.5	17.0	17.0	18.7	18.7	20.7	20.7	-	-	-	-
99	37	-	-	-	-	-	-	-	-	17.4	17.3	19.2	19.2	21.1	21.1	23.2	23.1	-	-
104	40	-	-	-	-	-	-	-	-	18.0	18.0	19.9	19.8	21.8	21.7	23.8	23.8	27.1	27.1

PEFY-P200VMHS-E-F

Outdoor air temp.		59°F FWB		63°F FWB		68°F FWB		73°F FWB		79°F FWB		82°F FWB		86°F FWB		90°F FWB		95°F FWB	
		15°C CWB		17°C CWB		20°C CWB		23°C CWB		26°C CWB		28°C CWB		30°C CWB		32°C CWB		35°C CWB	
°F DB	°C DB	°C DB	°C CWB	°C DB	°C CWB	°C DB	°C CWB	°C DB	°C CWB	°C DB	°C CWB	°C DB	°C CWB	°C DB	°C CWB	°C DB	°C CWB	°C DB	°C CWB
70	21	7.6	7.2	8.3	8.2	-	-	-	-	-	-	-	-	-	-	-	-	-	-
73	23	7.7	7.2	8.5	8.2	10.0	10.0	-	-	-	-	-	-	-	-	-	-	-	-
77	25	7.8	7.2	8.6	8.2	10.3	10.1	-	-	-	-	-	-	-	-	-	-	-	-
81	27	-	-	8.8	8.2	10.5	10.1	12.5	12.4	-	-	-	-	-	-	-	-	-	-
84	29	-	-	-	-	10.7	10.2	12.8	12.6	15.3	15.3	-	-	-	-	-	-	-	-
88	31	-	-	-	-	10.9	10.3	13.0	12.7	15.6	15.4	17.5	17.5	-	-	-	-	-	-
91	33	-	-	-	-	-	-	13.3	12.8	15.9	15.6	17.7	17.6	19.8	19.8	-	-	-	-
95	35	-	-	-	-	-	-	13.6	12.9	16.1	15.7	18.1	17.8	20.1	20.0	-	-	-	-
99	37	-	-	-	-	-	-	-	-	16.4	15.9	18.4	17.9	20.4	20.1	22.6	22.4	-	-
104	40	-	-	-	-	-	-	-	-	16.9	16.1	18.8	18.2	20.9	20.4	23.1	22.7	26.5	26.3

PEFY-P250VMHS-E-F

Outdoor air temp.		59°F FWB		63°F FWB		68°F FWB		73°F FWB		79°F FWB		82°F FWB		86°F FWB		90°F FWB		95°F FWB	
		15°C CWB		17°C CWB		20°C CWB		23°C CWB		26°C CWB		28°C CWB		30°C CWB		32°C CWB		35°C CWB	
°F DB	°C DB	°C DB	°C CWB	°C DB	°C CWB	°C DB	°C CWB	°C DB	°C CWB	°C DB	°C CWB	°C DB	°C CWB	°C DB	°C CWB	°C DB	°C CWB	°C DB	°C CWB
70	21	7.6	7.2	8.3	8.2	-	-	-	-	-	-	-	-	-	-	-	-	-	-
73	23	7.7	7.2	8.5	8.2	10.0	10.0	-	-	-	-	-	-	-	-	-	-	-	-
77	25	7.8	7.2	8.6	8.2	10.3	10.1	-	-	-	-	-	-	-	-	-	-	-	-
81	27	-	-	8.8	8.2	10.5	10.1	12.5	12.4	-	-	-	-	-	-	-	-	-	-
84	29	-	-	-	-	10.7	10.2	12.8	12.6	15.3	15.3	-	-	-	-	-	-	-	-
88	31	-	-	-	-	10.9	10.3	13.0	12.7	15.6	15.4	17.5	17.5	-	-	-	-	-	-
91	33	-	-	-	-	-	-	13.3	12.8	15.9	15.6	17.7	17.6	19.8	19.8	-	-	-	-
95	35	-	-	-	-	-	-	13.6	12.9	16.1	15.7	18.1	17.8	20.1	20.0	-	-	-	-
99	37	-	-	-	-	-	-	-	-	16.4	15.9	18.4	17.9	20.4	20.1	22.6	22.4	-	-
104	40	-	-	-	-	-	-	-	-	16.9	16.1	18.8	18.2	20.9	20.4	23.1	22.7	26.5	26.3

- The outlet air temperature table shows the lowest possible outlet air temperatures at High speed setting and when the total capacity of the indoor units is 100% of the outdoor unit capacity. The actual outlet air temperature may vary, depending on the outlet air temperature setting on the remote controller.
- Depending on the air conditioning load, outside temperature, and due to the activation of protection functions, the desired preset temperature may not always be achieved and the outlet air temperature may swing. Note that untreated outside air may be delivered directly into the room upon the activation of protection functions.

PEFY-P- VMHS-E-F

7-3. Heating capacity

PEFY-P125VMHS-E-F

SHC: Sensible Heat Capacity (kW)

Outdoor air temp.		16°FWB	23°FWB	27°FWB	32°FWB	36°FWB	39°FWB	43°FWB	50°FWB	57°FWB
		-9°CWB	-5°CWB	-2.9°CWB	0°CWB	2°CWB	4°CWB	6°CWB	10°CWB	14°CWB
°FDB	°CDB	SHC	SHC	SHC	SHC	SHC	SHC	SHC	SHC	SHC
18	-8	12.8	-	-	-	-	-	-	-	-
27	-3	-	14.2	-	-	-	-	-	-	-
32	0	-	-	13.2	-	-	-	-	-	-
37	3	-	-	-	12.3	12.3	-	-	-	-
45	7	-	-	-	-	11.0	11.0	11.0	-	-
52	11	-	-	-	-	-	-	9.8	9.8	-
59	15	-	-	-	-	-	-	-	8.6	8.6
64	18	-	-	-	-	-	-	-	7.7	7.7
68	20	-	-	-	-	-	-	-	-	7.1

PEFY-P200VMHS-E-F

Outdoor air temp.		16°FWB	23°FWB	27°FWB	32°FWB	36°FWB	39°FWB	43°FWB	50°FWB	57°FWB
		-9°CWB	-5°CWB	-2.9°CWB	0°CWB	2°CWB	4°CWB	6°CWB	10°CWB	14°CWB
°FDB	°CDB	SHC	SHC	SHC	SHC	SHC	SHC	SHC	SHC	SHC
18	-8	20.5	-	-	-	-	-	-	-	-
27	-3	-	22.7	-	-	-	-	-	-	-
32	0	-	-	21.2	-	-	-	-	-	-
37	3	-	-	-	19.7	19.7	-	-	-	-
45	7	-	-	-	-	17.8	17.8	17.8	-	-
52	11	-	-	-	-	-	-	15.8	15.8	-
59	15	-	-	-	-	-	-	-	13.8	13.8
64	18	-	-	-	-	-	-	-	12.3	12.3
68	20	-	-	-	-	-	-	-	-	11.4

PEFY-P250VMHS-E-F

Outdoor air temp.		16°FWB	23°FWB	27°FWB	32°FWB	36°FWB	39°FWB	43°FWB	50°FWB	57°FWB
		-9°CWB	-5°CWB	-2.9°CWB	0°CWB	2°CWB	4°CWB	6°CWB	10°CWB	14°CWB
°FDB	°CDB	SHC	SHC	SHC	SHC	SHC	SHC	SHC	SHC	SHC
18	-8	25.7	-	-	-	-	-	-	-	-
27	-3	-	28.3	-	-	-	-	-	-	-
32	0	-	-	26.5	-	-	-	-	-	-
37	3	-	-	-	24.7	24.7	-	-	-	-
45	7	-	-	-	-	22.2	22.2	22.2	-	-
52	11	-	-	-	-	-	-	19.7	19.7	-
59	15	-	-	-	-	-	-	-	17.3	17.3
64	18	-	-	-	-	-	-	-	15.4	15.4
68	20	-	-	-	-	-	-	-	-	14.2

- ♦The capacity table shows the maximum capacities of the indoor units at High speed setting and when the total capacity of the indoor units is 100% of the outdoor unit capacity. The actual capacity may vary, depending on the outlet air temperature setting on the remote controller.
- ♦Depending on the air conditioning load, outside temperature, and due to the activation of protection functions, the desired preset temperature may not always be achieved and the outlet air temperature may swing. Note that untreated outside air may be delivered directly into the room upon the activation of protection functions.

PEFY-P-VMHS-E-F

7-4. Outlet air temp. heated

PEFY-P125VMHS-E-F

Outdoor air temp.		16°FWB	23°FWB	27°FWB	32°FWB	36°FWB	39°FWB	43°FWB	50°FWB	57°FWB
°FDB	°CDB	-9°CWB	-5°CWB	-2.9°CWB	0°CWB	2°CWB	4°CWB	6°CWB	10°CWB	14°CWB
°FDB	°CDB	°CDB	°CDB	°CDB	°CDB	°CDB	°CDB	°CDB	°CDB	°CDB
18	-8	29.4	-	-	-	-	-	-	-	-
27	-3	-	39.7	-	-	-	-	-	-	-
32	0	-	-	39.9	-	-	-	-	-	-
37	3	-	-	-	40.1	40.1	-	-	-	-
45	7	-	-	-	-	40.4	40.4	40.4	-	-
52	11	-	-	-	-	-	-	40.8	40.8	-
59	15	-	-	-	-	-	-	-	41.0	41.3
64	18	-	-	-	-	-	-	-	41.3	41.3
68	20	-	-	-	-	-	-	-	-	41.4

PEFY-P200VMHS-E-F

Outdoor air temp.		16°FWB	23°FWB	27°FWB	32°FWB	36°FWB	39°FWB	43°FWB	50°FWB	57°FWB
°FDB	°CDB	-9°CWB	-5°CWB	-2.9°CWB	0°CWB	2°CWB	4°CWB	6°CWB	10°CWB	14°CWB
°FDB	°CDB	°CDB	°CDB	°CDB	°CDB	°CDB	°CDB	°CDB	°CDB	°CDB
18	-8	29.7	-	-	-	-	-	-	-	-
27	-3	-	40.0	-	-	-	-	-	-	-
32	0	-	-	40.3	-	-	-	-	-	-
37	3	-	-	-	40.6	40.7	-	-	-	-
45	7	-	-	-	-	40.8	40.9	41.0	-	-
52	11	-	-	-	-	-	-	41.2	41.4	-
59	15	-	-	-	-	-	-	-	41.5	41.7
64	18	-	-	-	-	-	-	-	41.7	41.8
68	20	-	-	-	-	-	-	-	-	41.9

PEFY-P250VMHS-E-F

Outdoor air temp.		16°FWB	23°FWB	27°FWB	32°FWB	36°FWB	39°FWB	43°FWB	50°FWB	57°FWB
°FDB	°CDB	-9°CWB	-5°CWB	-2.9°CWB	0°CWB	2°CWB	4°CWB	6°CWB	10°CWB	14°CWB
°FDB	°CDB	°CDB	°CDB	°CDB	°CDB	°CDB	°CDB	°CDB	°CDB	°CDB
18	-8	29.7	-	-	-	-	-	-	-	-
27	-3	-	40.0	-	-	-	-	-	-	-
32	0	-	-	40.3	-	-	-	-	-	-
37	3	-	-	-	40.6	40.7	-	-	-	-
45	7	-	-	-	-	40.8	40.9	41.0	-	-
52	11	-	-	-	-	-	-	41.2	41.4	-
59	15	-	-	-	-	-	-	-	41.5	41.7
64	18	-	-	-	-	-	-	-	41.6	41.8
68	20	-	-	-	-	-	-	-	-	41.9

- ♦The outlet air temperature table shows the highest possible outlet air temperatures at High speed setting and when the total capacity of the indoor units is 100% of the outdoor unit capacity. The actual outlet air temperature may vary, depending on the outlet air temperature setting on the remote controller.
- ♦Depending on the air conditioning load, outside temperature, and due to the activation of protection functions, the desired preset temperature may not always be achieved and the outlet air temperature may swing. Note that untreated outside air may be delivered directly into the room upon the activation of protection functions.

PEFY-P- VMHS-E-F

8. ELECTRICAL CHARACTERISTICS

Ceiling concealed (Fresh air intake type)

Symbols: MCA (Max.Circuit Amps =1.25xFLA), FLA (Full Load Amps)

IFM (Indoor Fan Motor), Output (Fan motor rated output)

PEFY-P-VMHS-E-F	Power supply			IFM	
	Volts/Hz	Range +-10%	MCA(A)	Output (kW)	FLA(A)
PEFY-P125VMHS-E-F	220-240V/50Hz 220-240V/60Hz	Max.: 264V Min.: 198V	2.64	0.244	2.11
PEFY-P200VMHS-E-F			3.22	0.375	2.57
PEFY-P250VMHS-E-F			4.32	0.375	3.45

PEFY-P-VMHS-E-F

9-1. Optional parts line up for the Indoor unit

	Long-life filter	Filter box	Drain pump
PEFY-P125VMHS-E-F	PAC-KE89LAF	PAC-KE140TB-F	PAC-DRP10DP-E2
PEFY-P200VMHS-E-F	PAC-KE85LAF	PAC-KE250TB-F	PAC-KE06DM-F
PEFY-P250VMHS-E-F	PAC-KE85LAF	PAC-KE250TB-F	PAC-KE06DM-F

PEFY-P-VMHS-E-F

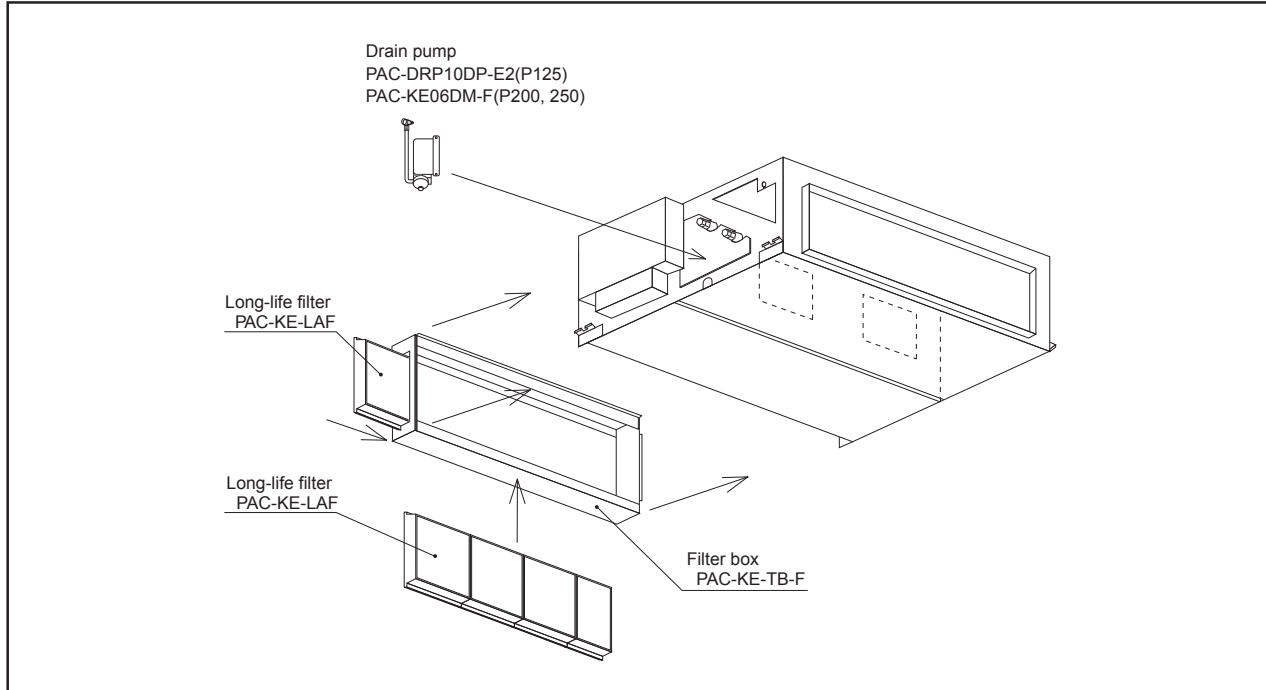

PEFY-P- VMHS-E-F

9-2. Long-life filter

Life span: 2,500 hr (Dust concentration 0.15mg/m³)
 *The actual dust situation affects the filter life span, which should be considered at the applying site.
 Material: Synthetic fiber unweaved cloth filter
 Static pressure loss is referred to 6 "FAN CHARACTERISTICS CURVES".
 Long-life filter should be used together with filter box PAC-KE-TB-F.

PAC-KE-LAF

Item	PAC-KE89LAF	PAC-KE85LAF	
Quantity	3	2	
	(298×300)	(411×600)	
Shape			

Detailed installation information should be referred to its Installation Manual.

PAC-KE-TB-F





Item	① Screw	② Filter box	③ Installation manual	
Quantity	10/12*	1	1	
Shape				*PAC-KE250TB has 12 pieces of screw.

Detailed installation information should be referred to its Installation Manual.

9-3. Drain pump

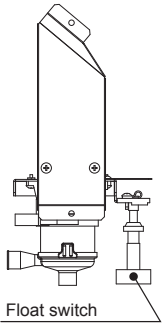
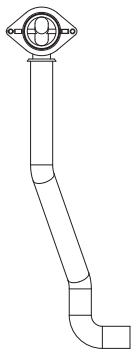
If drain water can not flow out the Indoor unit by gravity and gradient, a Drain-pump for draining is needed.
 Drain pump PAC-DRP10DP-E2 can pump water up to 550mm [21-11/16 in.] high from the drain pan.

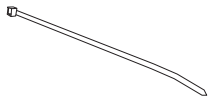

PAC-DRP10DP-E2

Item	① Drain pump ass'y	② Drain socket ass'y	③ Rubber plug	④ Band	⑤ PTT screw 4 × 10
Quantity	1	1	1	3	2 + 1 (spare)
Shape					

Detailed installation information should be referred to its Installation Manual.

If drain water can not flow out the Indoor unit by gravity and gradient, a Drain-pump for draining is needed.
 Drain pump PAC-KE06DM-F can pump water up to 700mm [27-9/16 in.] high from the drain pan.

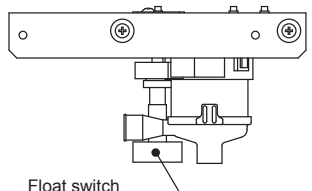
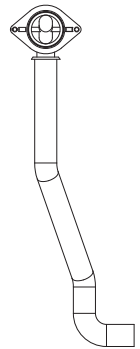
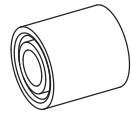
PAC-KE06DM-F

Item	① Drain pump ass'y	② Drain socket ass'y	③ Rubber plug	④ Band (Small)
Quantity	1	1	1	3
Shape				

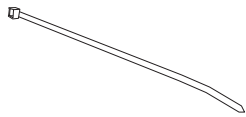
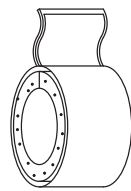
Item	⑤ PTT screw 4 × 10	⑥ Band (Large)	⑦ Insulation pipe
Quantity	4 + 1 (spare)	1	1
Shape			

PEFY-P-VMH5-E-F