

**PEFY-P-VMHS-E**

1. SPECIFICATIONS .....	1 - 82
2. EXTERNAL DIMENSIONS .....	1 - 85
3. CENTER OF GRAVITY .....	1 - 89
4. ELECTRICAL WIRING DIAGRAMS .....	1 - 90
5. SOUND LEVELS .....	1 - 92
5-1. Sound levels .....	1 - 92
5-2. NC curves .....	1 - 93
6. FAN CHARACTERISTICS CURVES .....	1 - 96
7. ELECTRICAL CHARACTERISTICS .....	1 - 102
8. OPTIONAL PARTS .....	1 - 103
8-1. Optional parts line up for the Indoor unit .....	1 - 103
8-2. Long-life filter .....	1 - 103
8-3. Drain pump .....	1 - 104

# 1. SPECIFICATIONS

Ceiling concealed (High static pressure type)

PEFY-P-VMHS-E

Model		PEFY-P40VMHS-E	PEFY-P50VMHS-E	PEFY-P63VMHS-E	PEFY-P71VMHS-E	
Power source		1-phase 220-230-240 V 50/60 Hz	1-phase 220-230-240 V 50/60 Hz	1-phase 220-230-240 V 50/60 Hz	1-phase 220-230-240 V 50/60 Hz	
Cooling capacity (Nominal)	*1 kW	4.5	5.6	7.1	8.0	
	*1 kcal/h	3,900	4,800	6,100	6,900	
	*1 BTU/h	15,400	19,100	24,200	27,300	
	*2 Power input kW	0.055	0.055	0.090	0.075	
	*2 Current input A	0.41 - 0.39 - 0.38	0.41 - 0.39 - 0.38	0.64 - 0.62 - 0.59	0.54 - 0.52 - 0.50	
Heating capacity (Nominal)	*3 kW	5.0	6.3	8.0	9.0	
	*3 kcal/h	4,300	5,400	6,900	7,700	
	*3 BTU/h	17,100	21,500	27,300	30,700	
	*2 Power input kW	0.055	0.055	0.090	0.075	
	*2 Current input A	0.41 - 0.39 - 0.38	0.41 - 0.39 - 0.38	0.64 - 0.62 - 0.59	0.54 - 0.52 - 0.50	
External finish		Galvanized steel plate	Galvanized steel plate	Galvanized steel plate	Galvanized steel plate	
External dimension H x W x D		mm 380 x 745 x 900	mm 380 x 745 x 900	mm 380 x 745 x 900	mm 380 x 1,030 x 900	
		in. 15 x 29-3/8 x 35-7/16	in. 15 x 29-3/8 x 35-7/16	in. 15 x 29-3/8 x 35-7/16	in. 15 x 40-9/16 x 35-7/16	
Net weight		kg (lbs) 35 (78)	kg (lbs) 35 (78)	kg (lbs) 35 (78)	kg (lbs) 45 (100)	
Heat exchanger		Cross fin (Aluminum fin and copper tube)	Cross fin (Aluminum fin and copper tube)	Cross fin (Aluminum fin and copper tube)	Cross fin (Aluminum fin and copper tube)	
FAN	Type x Quantity		Sirocco fan x 1	Sirocco fan x 1	Sirocco fan x 1	Sirocco fan x 2
	*4 External static press.	Pa	50 - <100> - <150> - <200>	50 - <100> - <150> - <200>	50 - <100> - <150> - <200>	50 - <100> - <150> - <200>
		mmH <sub>2</sub> O	5.1 - <10.2> - <15.3> - <20.4>	5.1 - <10.2> - <15.3> - <20.4>	5.1 - <10.2> - <15.3> - <20.4>	5.1 - <10.2> - <15.3> - <20.4>
	Motor Type		DC motor	DC motor	DC motor	DC motor
	Motor output kW		0.121	0.121	0.121	0.244
	Driving mechanism		Direct-driven by motor	Direct-driven by motor	Direct-driven by motor	Direct-driven by motor
	Air flow rate		(Low-Mid-High)	(Low-Mid-High)	(Low-Mid-High)	(Low-Mid-High)
		m <sup>3</sup> /min 10.0 - 12.0 - 14.0	m <sup>3</sup> /min 10.0 - 12.0 - 14.0	m <sup>3</sup> /min 13.5 - 16.0 - 19.0	m <sup>3</sup> /min 15.5 - 18.0 - 22.0	
		L/s 167 - 200 - 233	L/s 167 - 200 - 233	L/s 225 - 267 - 317	L/s 258 - 300 - 367	
		cfm 353 - 424 - 494	cfm 353 - 424 - 494	cfm 477 - 565 - 671	cfm 547 - 636 - 777	
Sound pressure level (measured in anechoic room)		(Low-Mid-High)	(Low-Mid-High)	(Low-Mid-High)	(Low-Mid-High)	
*2 dB <A>		20-23-27	20-23-27	24-27-32	24-26-30	
Insulation material		Polystyrene foam, Polyethylene foam, Urethane foam	Polystyrene foam, Polyethylene foam, Urethane foam	Polystyrene foam, Polyethylene foam, Urethane foam	Polystyrene foam, Polyethylene foam, Urethane foam	
Air filter		Option:Synthetic fiber unwoven cloth filter (long life filter) and filter box are recommended.	Option:Synthetic fiber unwoven cloth filter (long life filter) and filter box are recommended.	Option:Synthetic fiber unwoven cloth filter (long life filter) and filter box are recommended.	Option:Synthetic fiber unwoven cloth filter (long life filter) and filter box are recommended.	
Protection device		Fuse	Fuse	Fuse	Fuse	
Refrigerant control device		LEV	LEV	LEV	LEV	
Connectable outdoor unit		R410A CITY MULTI	R410A CITY MULTI	R410A CITY MULTI	R410A CITY MULTI	
Refrigerant piping diameter	Liquid (R410A)	mm (in.) 6.35 (1/4)Braze	mm (in.) 6.35 (1/4)Braze	mm (in.) 9.52 (3/8)Braze	mm (in.) 9.52 (3/8)Braze	
	Gas (R410A)	mm (in.) 12.7 (1/2)Braze	mm (in.) 12.7 (1/2)Braze	mm (in.) 15.88 (5/8)Braze	mm (in.) 15.88 (5/8)Braze	
Field drain pipe size		mm (in.) O.D.32 (1-1/4)	mm (in.) O.D.32 (1-1/4)	mm (in.) O.D.32 (1-1/4)	mm (in.) O.D.32 (1-1/4)	
Drawing	External	KL94C742	KL94C742	KL94C742	KL94C742	
	Wiring	KL94C743	KL94C743	KL94C743	KL94C743	
	Refrigerant cycle	-	-	-	-	
Standard attachment	Document	Installation Manual, Instruction Book	Installation Manual, Instruction Book	Installation Manual, Instruction Book	Installation Manual, Instruction Book	
	Accessory	Insulation pipe for refrigerant pipe, Washer, Drain hose, Tie band	Insulation pipe for refrigerant pipe, Washer, Drain hose, Tie band	Insulation pipe for refrigerant pipe, Washer, Drain hose, Tie band	Insulation pipe for refrigerant pipe, Washer, Drain hose, Tie band	
Optional parts	Drain pump kit	PAC-DRP10DP-E2	PAC-DRP10DP-E2	PAC-DRP10DP-E2	PAC-DRP10DP-E2	
	Long life filter	PAC-KE86LAF	PAC-KE86LAF	PAC-KE86LAF	PAC-KE86LAF	
	Filter box	PAC-KE63TB-F	PAC-KE63TB-F	PAC-KE63TB-F	PAC-KE63TB-F	
Remarks		* Details on foundation work, duct work, insulation work, electrical wiring, power source switch, and other items shall be referred to the Installation Manual. * Due to continuing improvement, above specifications may be subject to change without notice.				

Notes:	Unit converter
1.Nominal cooling conditions Indoor: 27°C D.B./19°C W.B. (81°F D.B./66°F W.B.), Outdoor: 35°C D.B. (95°F D.B.) Pipe length: 7.5 m (24-9/16 ft.), Level difference: 0 m (0 ft.)	kcal =kW x 860
2.The values are measured at the factory setting of external static pressure.	BTU/h =kW x 3,412
3.Nominal heating conditions Indoor: 20°C D.B. (68°F D.B.), Outdoor: 7°C D.B./6°C W.B. (45°F D.B./43°F W.B.) Pipe length: 7.5 m (24-9/16 ft.), Level difference: 0 m (0 ft.)	cfm =m <sup>3</sup> /min x 35.31
4.The factory setting of external static pressure is shown without < >. Refer to "Fan characteristics curves", according to the external static pressure, in DATA BOOK for the usable range of air flow rate.	lbs =kg/0.4536
	*Above specification data is subject to rounding variation.

# 1. SPECIFICATIONS

Ceiling concealed (High static pressure type)

Model		PEFY-P80VMHS-E	PEFY-P100VMHS-E	PEFY-P125VMHS-E	PEFY-P140VMHS-E	
Power source		1-phase 220-230-240 V 50/60 Hz	1-phase 220-230-240 V 50/60 Hz	1-phase 220-230-240 V 50/60 Hz	1-phase 220-230-240 V 50/60 Hz	
Cooling capacity (Nominal)	*1 kW	9.0	11.2	14.0	16.0	
	*1 kcal/h	7,700	9,600	12,000	13,800	
	*1 BTU/h	30,700	38,200	47,800	54,600	
	*2 Power input kW	0.090	0.160	0.160	0.190	
	*2 Current input A	0.63 - 0.61 - 0.58	1.05 - 1.01 - 0.96	1.05 - 1.01 - 0.96	1.24 - 1.19 - 1.14	
Heating capacity (Nominal)	*3 kW	10.0	12.5	16.0	18.0	
	*3 kcal/h	8,600	10,800	13,800	15,500	
	*3 BTU/h	34,100	42,700	54,600	61,400	
	*2 Power input kW	0.090	0.160	0.160	0.190	
	*2 Current input A	0.63 - 0.61 - 0.58	1.05 - 1.01 - 0.96	1.05 - 1.01 - 0.96	1.24 - 1.19 - 1.14	
External finish		Galvanized steel plate	Galvanized steel plate	Galvanized steel plate	Galvanized steel plate	
External dimension H x W x D		mm	380 x 1,030 x 900	380 x 1,195 x 900	380 x 1,195 x 900	
		in.	15 x 40-9/16 x 35-7/16	15 x 47-1/16 x 35-7/16	15 x 47-1/16 x 35-7/16	15 x 47-1/16 x 35-7/16
Net weight		kg (lbs)	45 (100)	51 (113)	51 (113)	
Heat exchanger		Cross fin (Aluminum fin and copper tube)	Cross fin (Aluminum fin and copper tube)	Cross fin (Aluminum fin and copper tube)	Cross fin (Aluminum fin and copper tube)	
FAN	Type x Quantity		Sirocco fan x 2	Sirocco fan x 2	Sirocco fan x 2	
	*4 External static press.	Pa	50 - <100> - <150> - <200>	50 - <100> - <150> - <200>	50 - <100> - <150> - <200>	50 - <100> - <150> - <200>
		mmH <sub>2</sub> O	5.1 - <10.2> - <15.3> - <20.4>	5.1 - <10.2> - <15.3> - <20.4>	5.1 - <10.2> - <15.3> - <20.4>	5.1 - <10.2> - <15.3> - <20.4>
	Motor Type		DC motor	DC motor	DC motor	DC motor
	Motor output kW		0.244	0.375	0.375	0.375
	Driving mechanism		Direct-driven by motor	Direct-driven by motor	Direct-driven by motor	Direct-driven by motor
	Air flow rate		(Low-Mid-High)	(Low-Mid-High)	(Low-Mid-High)	(Low-Mid-High)
m <sup>3</sup> /min			18.0 - 21.5 - 25.0	26.5 - 32.0 - 38.0	26.5 - 32.0 - 38.0	28.0 - 34.0 - 40.0
L/s			300 - 358 - 417	442 - 533 - 633	442 - 533 - 633	467 - 567 - 667
		cfm	636 - 759 - 883	936 - 1,130 - 1,342	936 - 1,130 - 1,342	989 - 1,201 - 1,412
Sound pressure level (measured in anechoic room)		(Low-Mid-High)	(Low-Mid-High)	(Low-Mid-High)	(Low-Mid-High)	
*2 dB <A>		25-27-30	27-31-34	27-31-34	27-32-36	
Insulation material		Polystyrene foam, Polyethylene foam, Urethane foam	Polystyrene foam, Polyethylene foam, Urethane foam	Polystyrene foam, Polyethylene foam, Urethane foam	Polystyrene foam, Polyethylene foam, Urethane foam	
Air filter		Option:Synthetic fiber unwoven cloth filter (long life filter) and filter box are recommended.	Option:Synthetic fiber unwoven cloth filter (long life filter) and filter box are recommended.	Option:Synthetic fiber unwoven cloth filter (long life filter) and filter box are recommended.	Option:Synthetic fiber unwoven cloth filter (long life filter) and filter box are recommended.	
Protection device		Fuse	Fuse	Fuse	Fuse	
Refrigerant control device		LEV	LEV	LEV	LEV	
Connectable outdoor unit		R410A CITY MULTI	R410A CITY MULTI	R410A CITY MULTI	R410A CITY MULTI	
Refrigerant piping diameter	Liquid (R410A)	mm (in.)	9.52 (3/8)Braze	9.52 (3/8)Braze	9.52 (3/8)Braze	
	Gas (R410A)	mm (in.)	15.88 (5/8)Braze	15.88 (5/8)Braze	15.88 (5/8)Braze	
Field drain pipe size		mm (in.)	O.D.32 (1-1/4)	O.D.32 (1-1/4)	O.D.32 (1-1/4)	
Drawing	External		KL94C742	KL94C742	KL94C742	
	Wiring		KL94C743	KL94C743	KL94C743	
	Refrigerant cycle		-	-	-	
Standard attachment	Document	Installation Manual, Instruction Book	Installation Manual, Instruction Book	Installation Manual, Instruction Book	Installation Manual, Instruction Book	
	Accessory	Insulation pipe for refrigerant pipe, Washer, Drain hose, Tie band	Insulation pipe for refrigerant pipe, Washer, Drain hose, Tie band	Insulation pipe for refrigerant pipe, Washer, Drain hose, Tie band	Insulation pipe for refrigerant pipe, Washer, Drain hose, Tie band	
Optional parts	Drain pump kit	PAC-DRP10DP-E2	PAC-DRP10DP-E2	PAC-DRP10DP-E2	PAC-DRP10DP-E2	
	Long life filter	PAC-KE88LAF	PAC-KE89LAF	PAC-KE89LAF	PAC-KE89LAF	
	Filter box	PAC-KE99TB-F	PAC-KE140TB-F	PAC-KE140TB-F	PAC-KE140TB-F	
Remarks		* Details on foundation work, duct work, insulation work, electrical wiring, power source switch, and other items shall be referred to the Installation Manual. * Due to continuing improvement, above specifications may be subject to change without notice.				

PEFY-P-VMHS-E

Notes:	Unit converter
1.Nominal cooling conditions Indoor: 27°C D.B./19°C W.B. (81°F D.B./66°F W.B.), Outdoor: 35°C D.B. (95°F D.B.) Pipe length: 7.5 m (24-9/16 ft.), Level difference: 0 m (0 ft.)	kcal =kW x 860
2.The values are measured at the factory setting of external static pressure.	BTU/h =kW x 3,412
3.Nominal heating conditions Indoor: 20°C D.B. (68°F D.B.), Outdoor: 7°C D.B./6°C W.B. (45°F D.B./43°F W.B.) Pipe length: 7.5 m (24-9/16 ft.), Level difference: 0 m (0 ft.)	cfm =m <sup>3</sup> /min x 35.31
4.The factory setting of external static pressure is shown without < > . Refer to "Fan characteristics curves", according to the external static pressure, in DATA BOOK for the usable range of air flow rate.	lbs =kg/0.4536
	*Above specification data is subject to rounding variation.

# 1. SPECIFICATIONS

Ceiling concealed (High static pressure type)

PEFY-P-VMHS-E

Model			PEFY-P200VMHS-E	PEFY-P250VMHS-E		
Power source			1-phase 220-230-240V 50/60Hz	1-phase 220-230-240V 50/60Hz		
Cooling capacity (Nominal)	*1	kW	22.4	28.0		
	*1	kcal / h	19,300	24,100		
	*1	BTU / h	76,400	95,500		
	*2	Power input	kW	0.63	0.82	
	*2	Current input	A	3.47 - 3.32 - 3.18 (220-230-240V)	4.72 - 4.43 - 4.14 (220-230-240V)	
Heating capacity (Nominal)	*3	kW	25.0	31.5		
	*3	kcal / h	21,500	27,100		
	*3	BTU / h	85,300	107,500		
	*2	Power input	kW	0.63	0.82	
	*2	Current input	A	3.47 - 3.32 - 3.18 (220-230-240V)	4.72 - 4.43 - 4.14 (220-230-240V)	
External finish			Galvanized steel plate	Galvanized steel plate		
External dimension HxWxD			mm	470 x 1,250 x 1,120	470 x 1,250 x 1,120	
			inch	18-1/2 x 49-1/4 x 44-1/8	18-1/2 x 49-1/4 x 44-1/8	
Net weight			kg(lbs)	97(214)	100(221)	
Heat exchanger			Cross fin (Aluminum fin and copper tube)	Cross fin (Aluminum fin and copper tube)		
FAN	Type x Quantity		Sirocco fan x 2	Sirocco fan x 2		
	*4	External static press.	Pa	<50> - <100> - 150 - <200> - <250>	<50> - <100> - 150 - <200> - <250>	
			mmH <sub>2</sub> O	<5.1> - <10.2> - 15.3 - <20.4> - <25.5>	<5.1> - <10.2> - 15.3 - <20.4> - <25.5>	
	Motor Type		DC motor	DC motor		
	Motor output		kW	0.870	0.870	
	Driving mechanism		Inverter-control	Inverter-control		
	Air flow rate		(Low-Mid-High)	(Low-Mid-High)		
			m <sup>3</sup> / min	50.0 - 61.0 - 72.0	58.0 - 71.0 - 84.0	
		L/s	833 - 1,017 - 1,200	967 - 1,183 - 1,400		
		cfm	1,766 - 2,154 - 2,542	2,048 - 2,507 - 2,966		
Sound pressure level (measured in anechoic room)			(Low-Mid-High)	(Low-Mid-High)		
			*2 dB <A>	36-39-43	39-42-46	
Insulation material			EPS, Polyethylene foam, Urethane foam	EPS, Polyethylene foam, Urethane foam		
Air filter			Option: Synthetic fiber unwoven cloth filter (long life filter) and filter box are recommended.	Option: Synthetic fiber unwoven cloth filter (long life filter) and filter box are recommended.		
Protection device			Fuse	Fuse		
Refrigerant control device			LEV	LEV		
Connectable outdoor unit			R410A CITY MULTI	R410A CITY MULTI		
Diameter of refrigerant pipe	Liquid (R410A)	mm(inch)	9.52(3/8")Braze	9.52(3/8")Braze		
	Gas (R410A)	mm(inch)	19.05(3/4")Braze	22.22(7/8")Braze		
Field drain pipe size			mm(inch)	O.D.32(1-1/4")	O.D.32(1-1/4")	
Drawing	External		KD94G757	KD94G757		
	Wiring		KD94G911	KD94G911		
	Refrigerant cycle		-	-		
Standard attachment	Document		Installation Manual, Instruction Book	Installation Manual, Instruction Book		
	Accessory		Insulation pipe for refrigerant pipe, Washer, Drain hose, Tie band	Insulation pipe for refrigerant pipe, Washer, Drain hose, Tie band		
Optional parts	Drain pump kit		PAC-KE05DM-F	PAC-KE05DM-F		
	Long life filter		PAC-KE85LAF	PAC-KE85LAF		
	Filter box		PAC-KE250TB-F	PAC-KE250TB-F		
Remark			* Details on foundation work, duct work, insulation work, electrical wiring, power source switch, and other items shall be referred to the Installation Manual. * Due to continuing improvement, above specifications may be subject to change without notice.			

Notes:	Unit converter
1.Nominal cooling conditions (subject to JIS B8615-2) Indoor: 27°CDB/19°CWB (81°FDB/66°FWB), Outdoor: 35°CDB (95°FDB) Pipe length: 7.5m (24-9/16"ft.), Level difference: 0m (0ft.)	kcal/h =kW x 860 BTU/h =kW x 3,412 cfm =m <sup>3</sup> /min x 35.31 lbs =kg/0.4536
2.The values are measured at the factory setting of external static pressure.	
3.Nominal heating conditions (subject to JIS B8615-2) Indoor: 20°CDB (68°FDB), Outdoor: 7°CDB/6°CWB (45°FDB/43°FWB) Pipe length: 7.5m (24-9/16"ft.) Level, difference: 0m(0ft.)	
4.The factory setting of external static pressure is shown without < > . Refer to "Fan characteristics curves", according to the external static pressure, in DATA BOOK for the usable range of air flow rate.	*Above specification data is subject to rounding variation.

## 2. EXTERNAL DIMENSIONS

Ceiling concealed (High static pressure type)

### PEFY-P40, 50, 63, 71, 80, 100, 125, 140VMHS-E

Unit: mm

- Note 1. Use an M10 screw for the suspension bolt (field supply).  
 2. This drawing is for PEFY-P71, 80, 100, 125, 140VMHS-E models, which have 2 fans. PEFY-P40, 50, 63VMHS-E models have 1 fan.  
 3. Make sure to install the air filter (field supply) on the air intake side. In case field supplied air filter is used, attach it where the filter service is easily done.

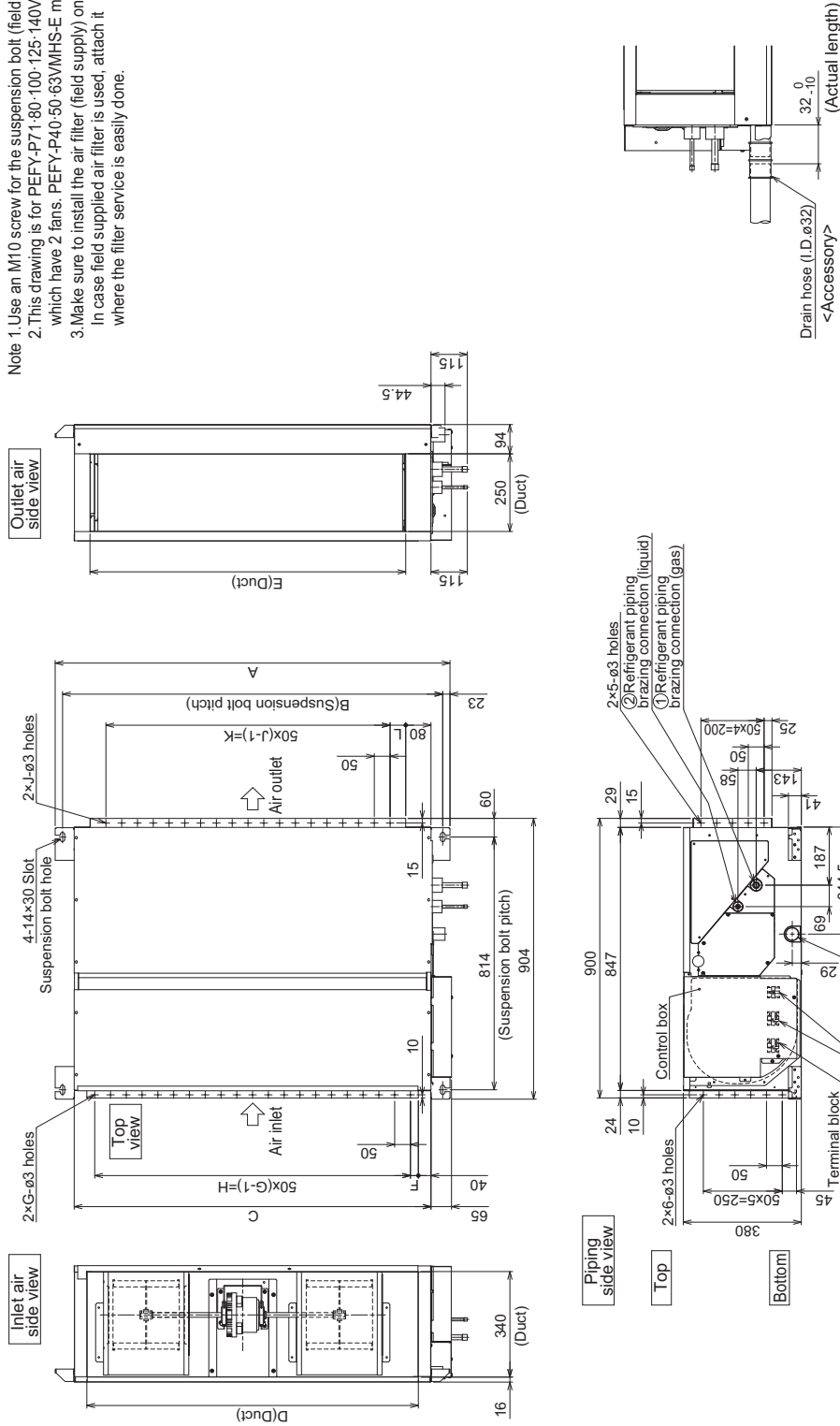

Model	A	B	C	D	E	F	G	H	J	K	L	① Gas pipe ② Liquid pipe	
												ø12.7	ø6.35
PEFY-P40-50VMHS-E	800	754	680	600	550	50	11	500	10	450	50		
PEFY-P63VMHS-E													
PEFY-P71-80VMHS-E	1085	1039	965	885	835	42.5	17	800	15	700	67	ø15.88	ø9.52
PEFY-P100-125-140VMHS-E	1250	1204	1130	1050	1000	25	21	1000	19	900	50		

PEFY-P-VMHS-E

PEFY-P40, 50, 63, 71, 80, 100, 125, 140VMHS-E

Unit: mm

[Maintenance access space]

Secure enough access space to allow for the maintenance, inspection, and replacement of the motor, fan, heat exchanger, drain pan and control box in one of the following ways.  
 Select an installation site for the indoor unit so that its maintenance access space will not be obstructed by beam or other objects.

Create access door 1 (450x450mm) for the maintenance from the unit side when the thermistor, LEV and control box is exchanged. (Fig.2,4)

(1) When a space of 300mm or more is available below the unit between the unit and the ceiling.  
 Create access door 2 (600x600mm) for the maintenance from the bottom when the motor, fan, heat exchanger and drain pan is cleaned(exchanged). (Fig.2)

(2) When a space of less than 300mm is available below the unit between the unit and the ceiling.  
 (At least 20mm of space should be left below the unit as shown in Fig.3.)  
 Create access door 3 for the maintenance from the bottom when the motor, fan, heat exchanger and drain pan is cleaned(exchanged). (Fig.4)

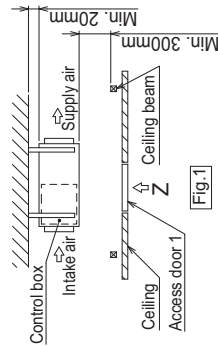

Fig.1

Model	C	M	N
PEFY-P40-50VMHS-E	680	780	0-50
PEFY-P63VMHS-E	965	1065	100-150
PEFY-P100-125-140VMHS-E	1130	1230	200-250

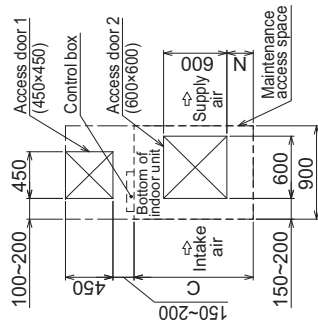

Fig.2 (Viewed from the direction of the arrow Z)

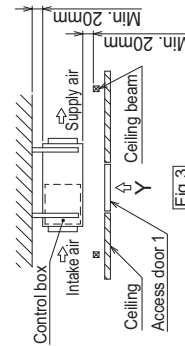

Fig.3

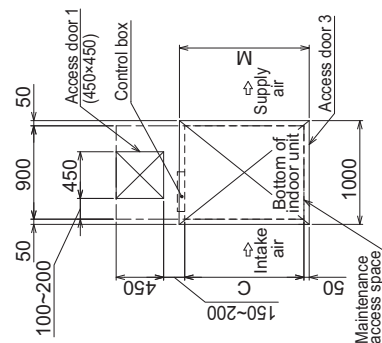

Fig.4 (Viewed from the direction of the arrow Y)

## 2. EXTERNAL DIMENSIONS

Ceiling concealed (High static pressure type)

PEFY-P200, 250VMHS-E

Unit: mm

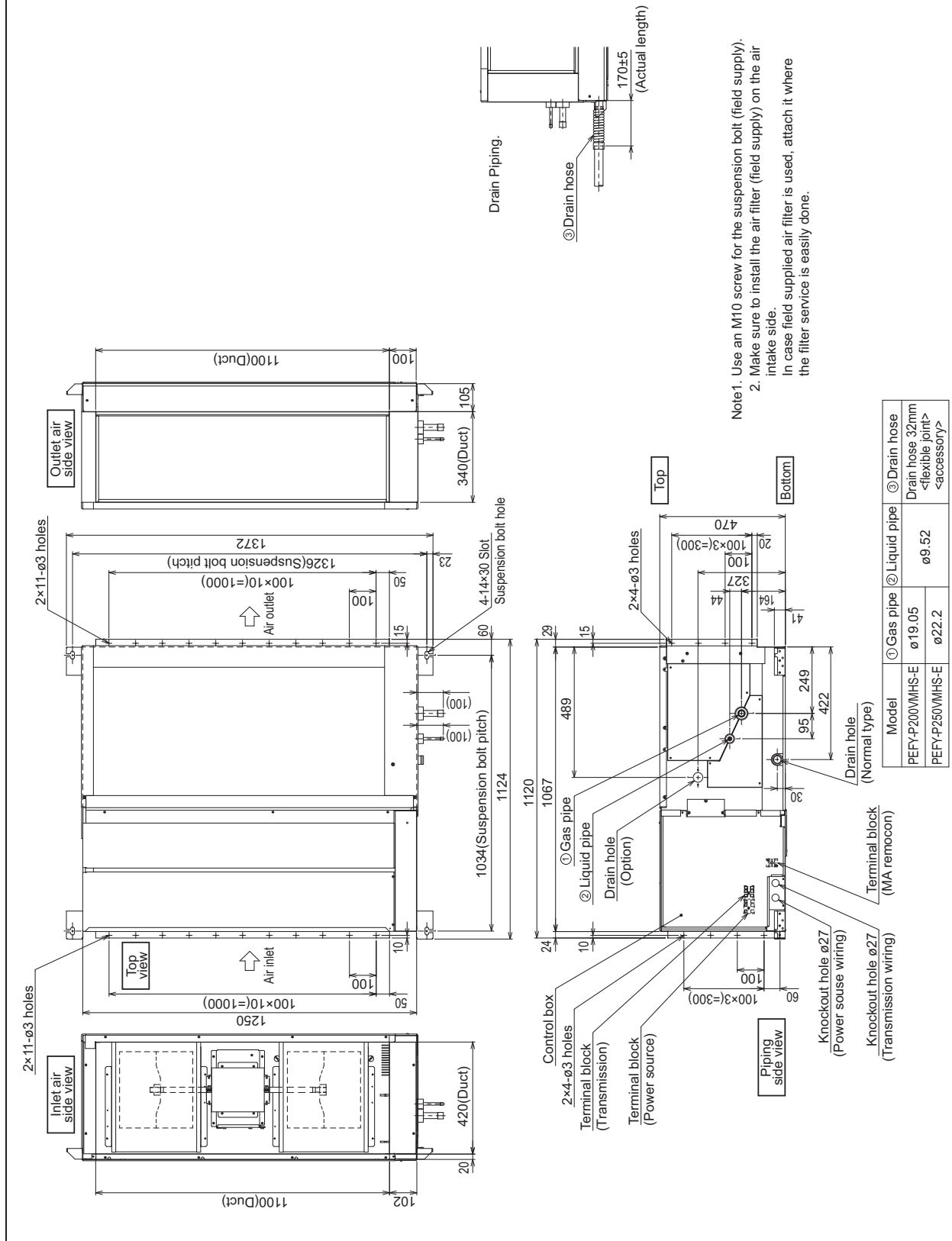

PEFY-P-VMHS-E

PEFY-P200, 250VMHS-E

Unit: mm

[Maintenance access space]

Secure enough access space to allow for the maintenance, inspection, and replacement of the motor, fan, heat exchanger, drain pan and control box in one of the following ways.  
 Select an installation site for the indoor unit so that its maintenance access space will not be obstructed by beam or other objects.

Create access door 1 (450x450mm) for the maintenance from the unit side when the thermistor, LEV and control box is exchanged. (Fig. 2.4)

(1) When a space of 500mm or more is available below the unit between the unit and the ceiling.  
 Create access door 2 (600x600mm) for the maintenance from the bottom when the motor, fan, heat exchanger and drain pan is cleaned(exchanged). (Fig. 2)

(2) When a space of less than 500mm is available below the unit between the unit and the ceiling.  
 (At least 20mm of space should be left below the unit as shown in Fig. 3.)  
 Create access door 3 for the maintenance from the bottom when the motor, fan, heat exchanger and drain pan is cleaned(exchanged). (Fig. 4)

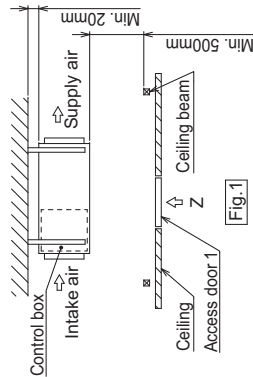

[Fig. 1]

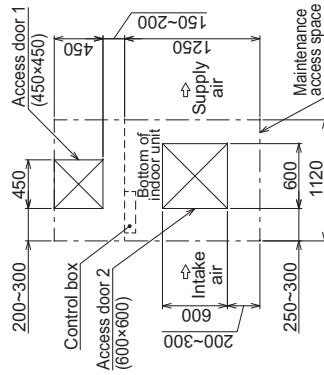

[Fig. 2] (Viewed from the direction of the arrow Z)

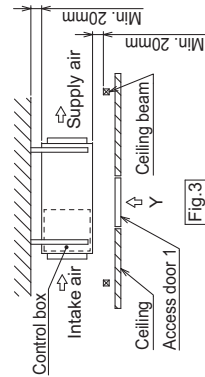

[Fig. 3]

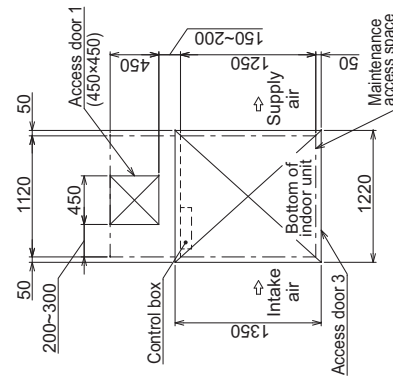

[Fig. 4] (Viewed from the direction of the arrow Y)



PEFY-P40, 50, 63, 71, 80, 100, 125, 140, 200, 250VMHS-E

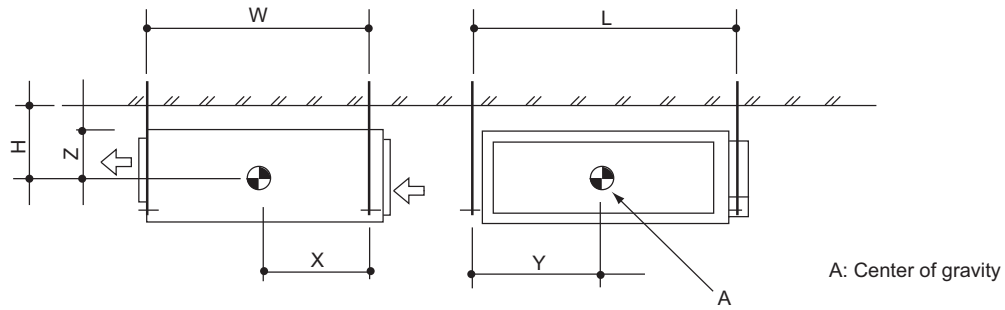

(mm)[in]

Model name	W	L	H	X	Y	Z
PEFY-P40VMHS-E	814 [32-1/16]	754 [29-11/16]	210 [8-9/32]	374 [14-3/4]	440 [17-11/32]	190 [7-1/2]
PEFY-P50VMHS-E	814 [32-1/16]	754 [29-11/16]	210 [8-9/32]	374 [14-3/4]	440 [17-11/32]	190 [7-1/2]
PEFY-P63VMHS-E	814 [32-1/16]	754 [29-11/16]	210 [8-9/32]	374 [14-3/4]	440 [17-11/32]	190 [7-1/2]
PEFY-P71VMHS-E	814 [32-1/16]	1039 [40-15/16]	210 [8-9/32]	364 [14-11/32]	548 [21-5/8]	190 [7-1/2]
PEFY-P80VMHS-E	814 [32-1/16]	1039 [40-15/16]	210 [8-9/32]	364 [14-11/32]	548 [21-5/8]	190 [7-1/2]
PEFY-P100VMHS-E	814 [32-1/16]	1204 [47-13/32]	210 [8-9/32]	364 [14-11/32]	649 [25-9/16]	190 [7-1/2]
PEFY-P125VMHS-E	814 [32-1/16]	1204 [47-13/32]	210 [8-9/32]	364 [14-11/32]	649 [25-9/16]	190 [7-1/2]
PEFY-P140VMHS-E	814 [32-1/16]	1204 [47-13/32]	210 [8-9/32]	364 [14-11/32]	649 [25-9/16]	190 [7-1/2]
PEFY-P200VMHS-E	1034 [40-23/32]	1326 [52-7/32]	255 [10-1/16]	462 [18-7/32]	660 [25-32/32]	235 [9-9/32]
PEFY-P250VMHS-E	1034 [40-23/32]	1326 [52-7/32]	255 [10-1/16]	462 [18-7/32]	660 [25-32/32]	235 [9-9/32]

PEFY-P-VMHS-E





5-1. Sound levels

PEFY-P-VMHS-E

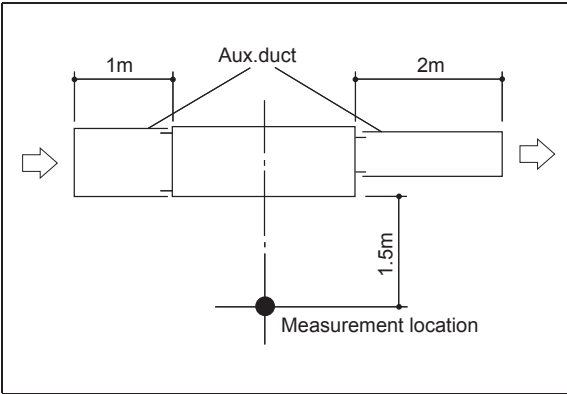

\* Measured in anechoic room.

Sound level at anechoic room: Low-Mid-High

		Sound level dB (A)			
		50Pa	100Pa	150Pa	200Pa
PEFY-P40VMHS-E	220-240V	20 - 23 - 27	24 - 28 - 33	29 - 33 - 37	31 - 36 - 39
PEFY-P50VMHS-E	220-240V	20 - 23 - 27	24 - 28 - 33	29 - 33 - 37	31 - 36 - 39
PEFY-P63VMHS-E	220-240V	24 - 27 - 32	27 - 30 - 35	30 - 34 - 38	33 - 37 - 41
PEFY-P71VMHS-E	220-240V	24 - 26 - 30	27 - 29 - 34	29 - 33 - 38	32 - 36 - 41
PEFY-P80VMHS-E	220-240V	25 - 27 - 30	28 - 31 - 35	31 - 35 - 38	34 - 38 - 42
PEFY-P100VMHS-E	220-240V	27 - 31 - 34	31 - 34 - 39	33 - 37 - 42	35 - 40 - 45
PEFY-P125VMHS-E	220-240V	27 - 31 - 34	31 - 34 - 39	33 - 37 - 42	35 - 40 - 45
PEFY-P140VMHS-E	220-240V	27 - 32 - 36	31 - 35 - 39	33 - 38 - 42	36 - 40 - 45

Sound level at anechoic room: Low-Mid-High

		Sound level dB (A)				
		50Pa	100Pa	150Pa	200Pa	250Pa
PEFY-P200VMHS-E	220-240V	32 - 35 - 39	34 - 37 - 41	36 - 39 - 43	38 - 41 - 45	40 - 43 - 47
PEFY-P250VMHS-E	220-240V	35 - 38 - 42	37 - 40 - 44	39 - 42 - 46	41 - 44 - 48	43 - 46 - 50

PEFY-P-VMHS-E

5-2. NC curves

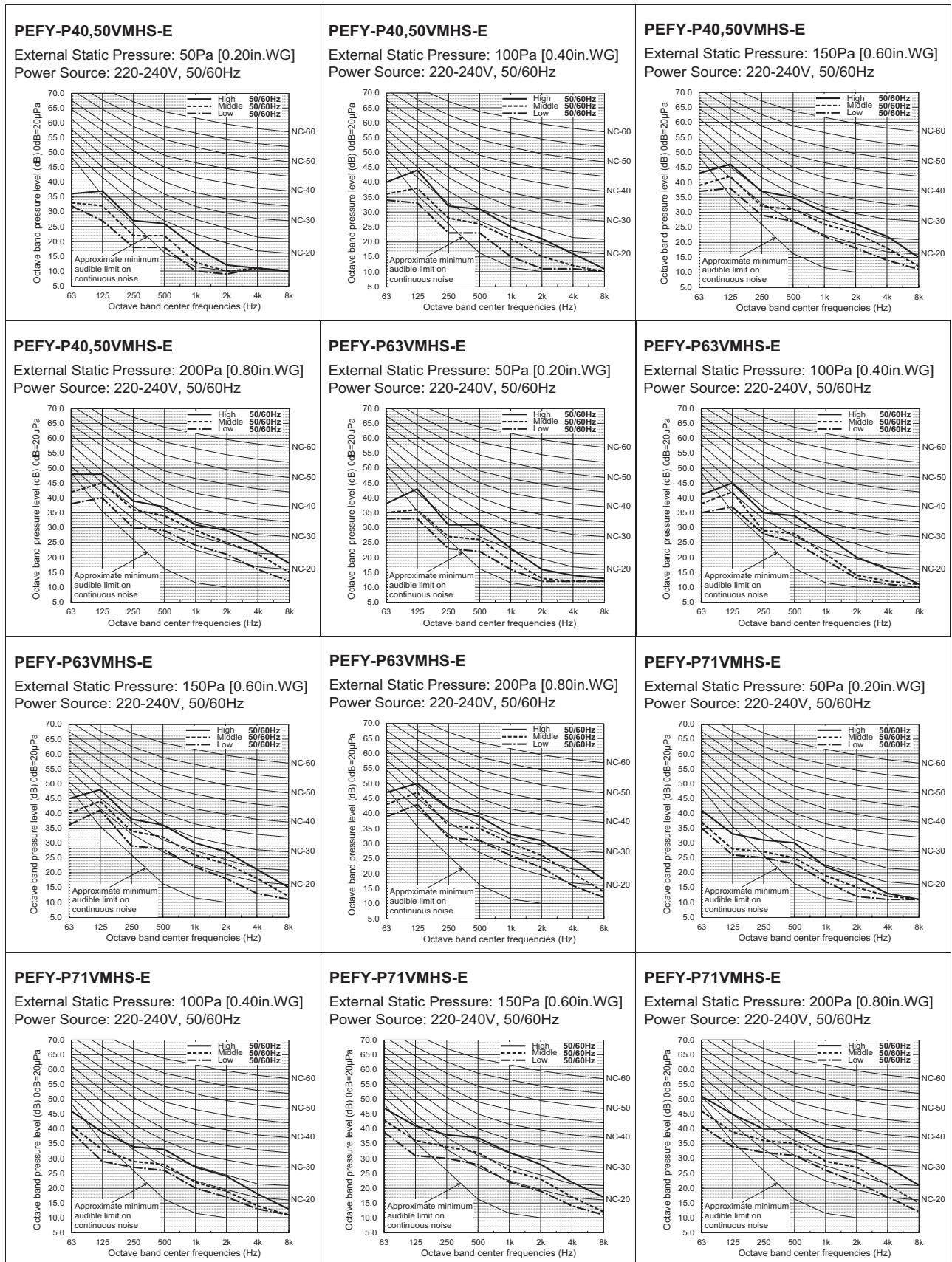

PEFY-P-VMHS-E

PEFY-P-VMHS-E

**PEFY-P80VMHS-E**

External Static Pressure: 50Pa [0.20in.WG]  
Power Source: 220-240V, 50/60Hz

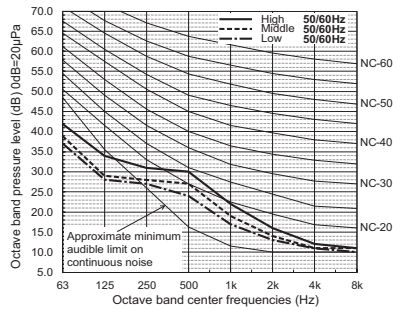

**PEFY-P80VMHS-E**

External Static Pressure: 100Pa [0.40in.WG]  
Power Source: 220-240V, 50/60Hz

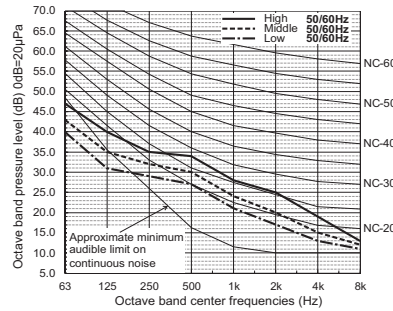

**PEFY-P80VMHS-E**

External Static Pressure: 150Pa [0.60in.WG]  
Power Source: 220-240V, 50/60Hz

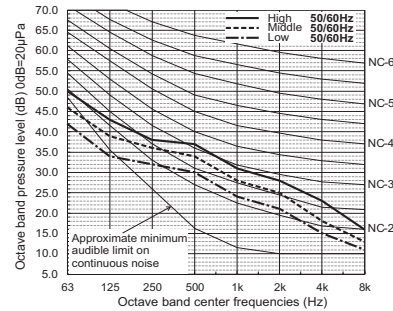

**PEFY-P80VMHS-E**

External Static Pressure: 200Pa [0.80in.WG]  
Power Source: 220-240V, 50/60Hz

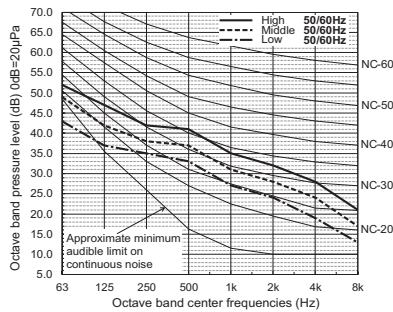

**PEFY-P100,125VMHS-E**

External Static Pressure: 50Pa [0.20in.WG]  
Power Source: 220-240V, 50/60Hz

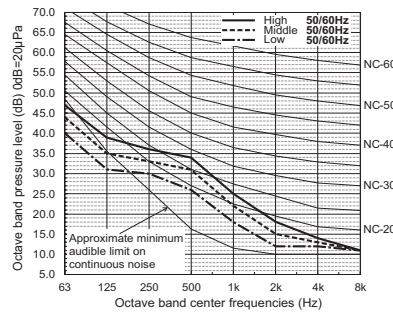

**PEFY-P100,125VMHS-E**

External Static Pressure: 100Pa [0.40in.WG]  
Power Source: 220-240V, 50/60Hz

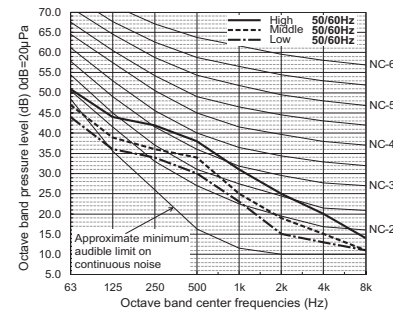

**PEFY-P100,125VMHS-E**

External Static Pressure: 150Pa [0.60in.WG]  
Power Source: 220-240V, 50/60Hz

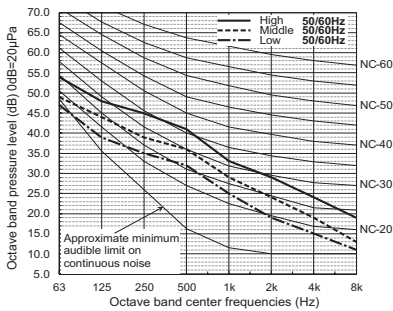

**PEFY-P100,125VMHS-E**

External Static Pressure: 200Pa [0.80in.WG]  
Power Source: 220-240V, 50/60Hz

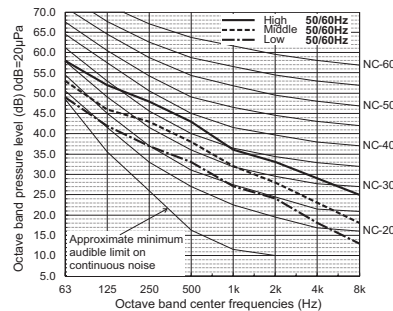

**PEFY-P140VMHS-E**

External Static Pressure: 50Pa [0.20in.WG]  
Power Source: 220-240V, 50/60Hz

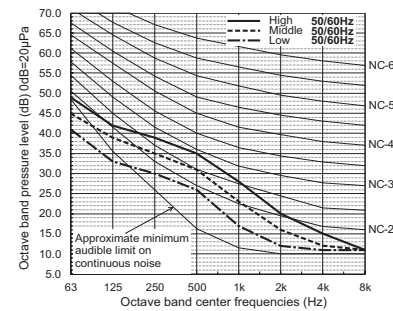

**PEFY-P140VMHS-E**

External Static Pressure: 100Pa [0.40in.WG]  
Power Source: 220-240V, 50/60Hz

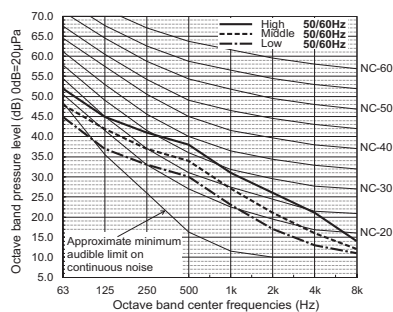

**PEFY-P140VMHS-E**

External Static Pressure: 150Pa [0.60in.WG]  
Power Source: 220-240V, 50/60Hz

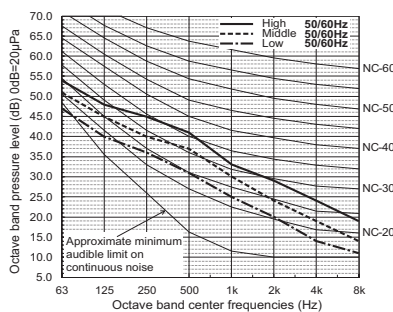

**PEFY-P140VMHS-E**

External Static Pressure: 200Pa [0.80in.WG]  
Power Source: 220-240V, 50/60Hz

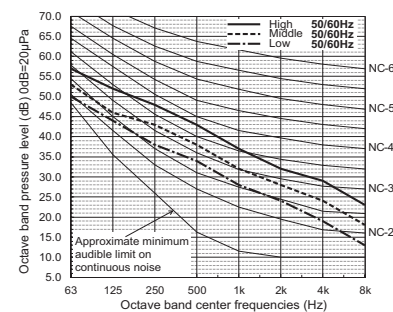

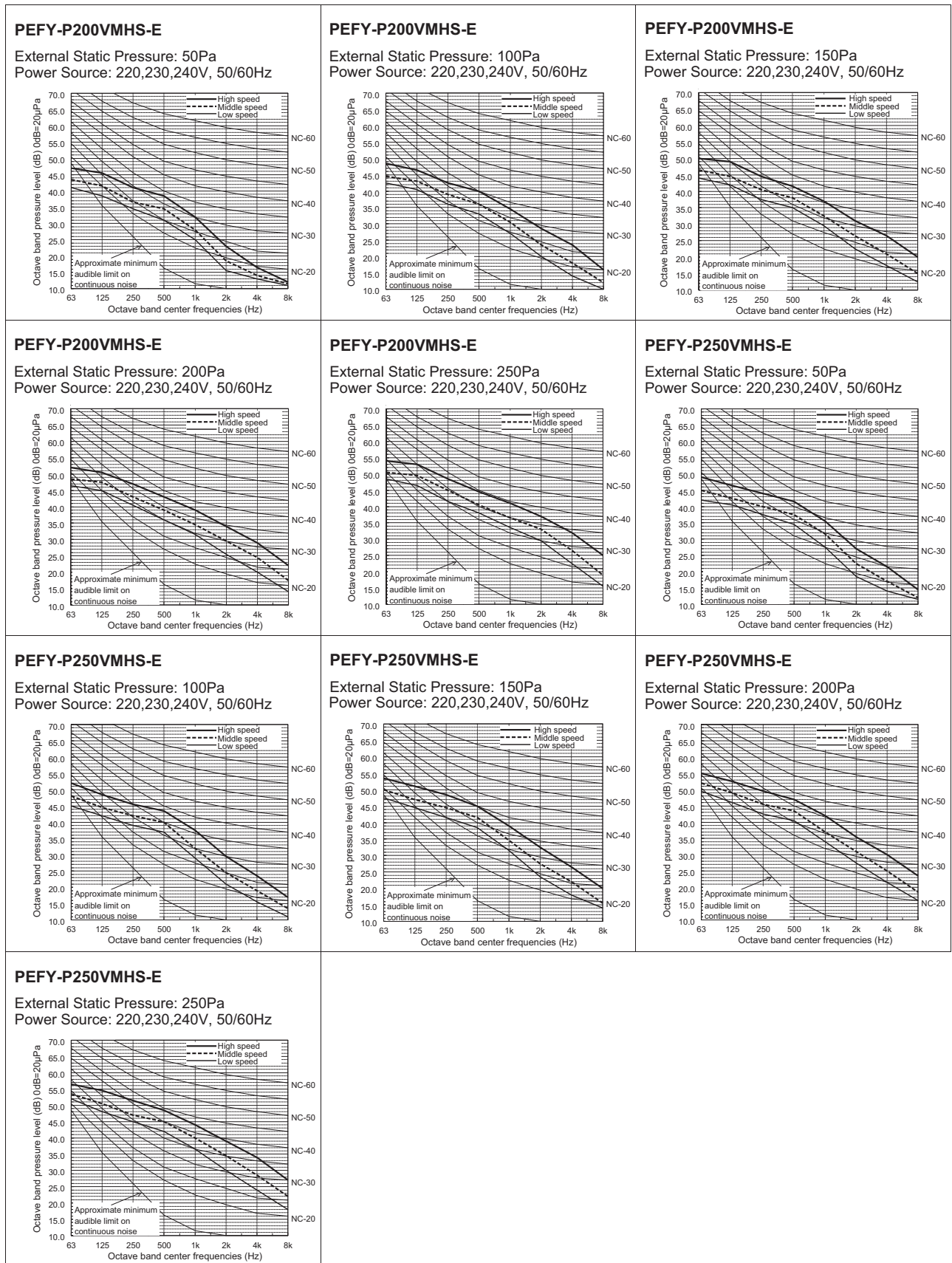

# 6. FAN CHARACTERISTICS CURVES

Ceiling concealed (High static pressure type)

PEFY-P-VMHS-E

**PEFY-P40, 50VMHS-E**  
 External static pressure : 50Pa  
 Power source : 220-240V, 50/60Hz

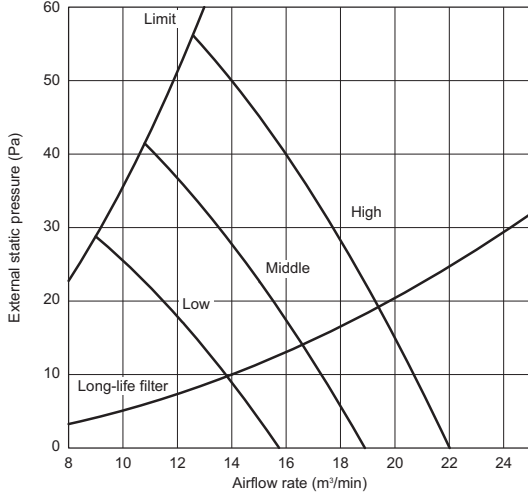

**PEFY-P40, 50VMHS-E**  
 External static pressure : 100Pa  
 Power source : 220-240V, 50/60Hz

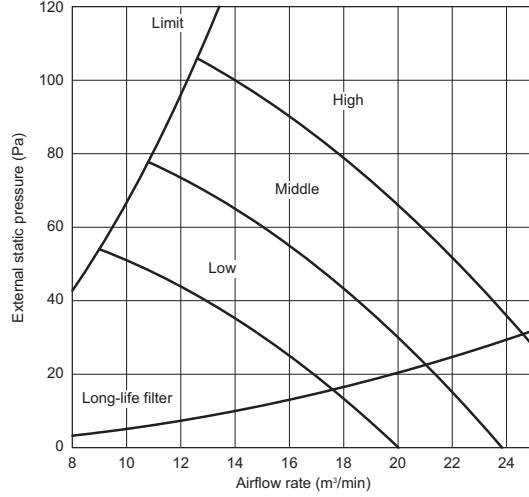

**PEFY-P40, 50VMHS-E**  
 External static pressure : 150Pa  
 Power source : 220-240V, 50/60Hz

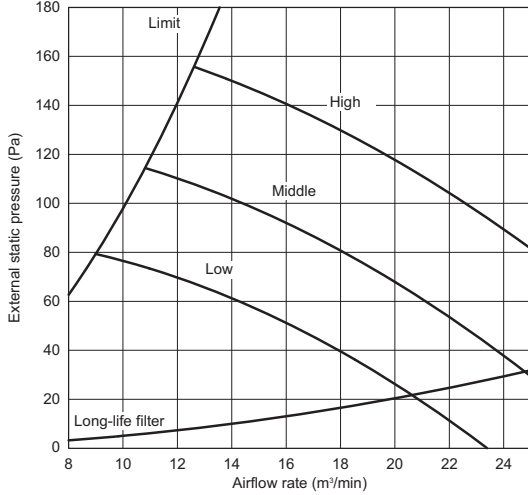

**PEFY-P40, 50VMHS-E**  
 External static pressure : 200Pa  
 Power source : 220-240V, 50/60Hz

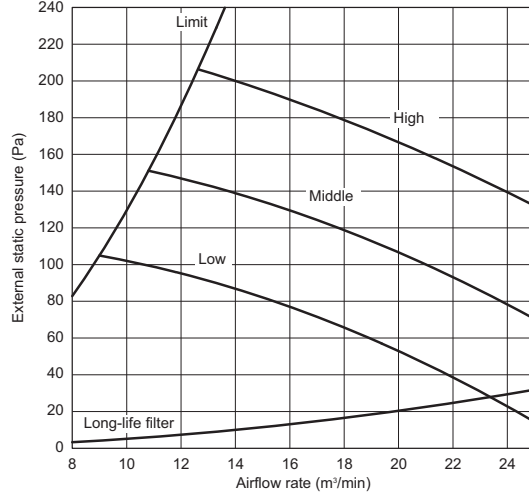

**PEFY-P63VMHS-E**  
 External static pressure : 50Pa  
 Power source : 220-240V, 50/60Hz

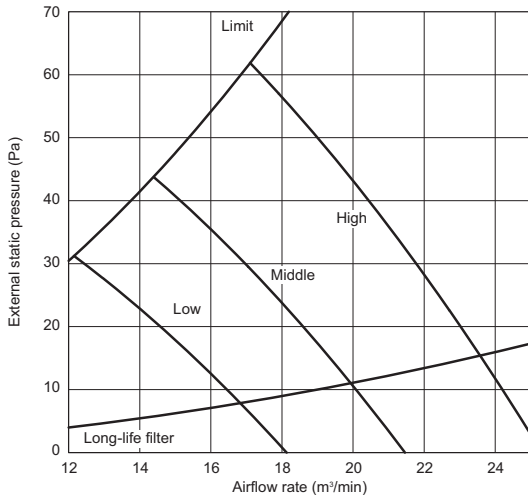

**PEFY-P63VMHS-E**  
 External static pressure : 100Pa  
 Power source : 220-240V, 50/60Hz

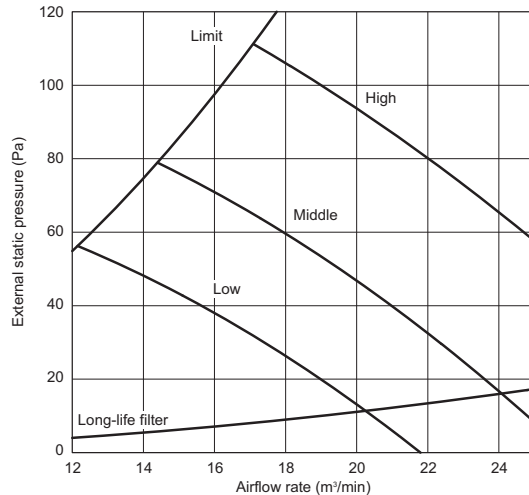



## 6. FAN CHARACTERISTICS CURVES

Ceiling concealed (High static pressure type)

### PEFY-P63VMHS-E

External static pressure : 150Pa  
Power source : 220-240V, 50/60Hz

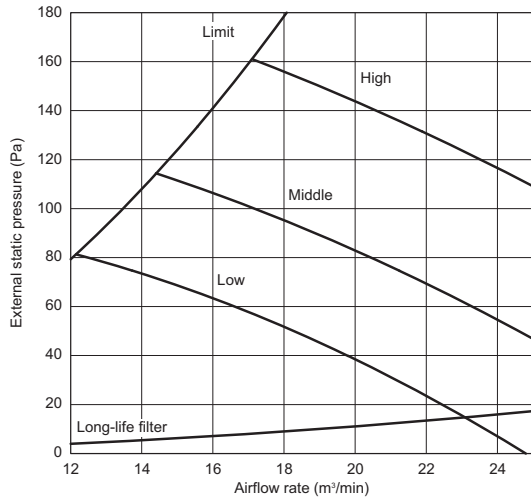

### PEFY-P63VMHS-E

External static pressure : 200Pa  
Power source : 220-240V, 50/60Hz

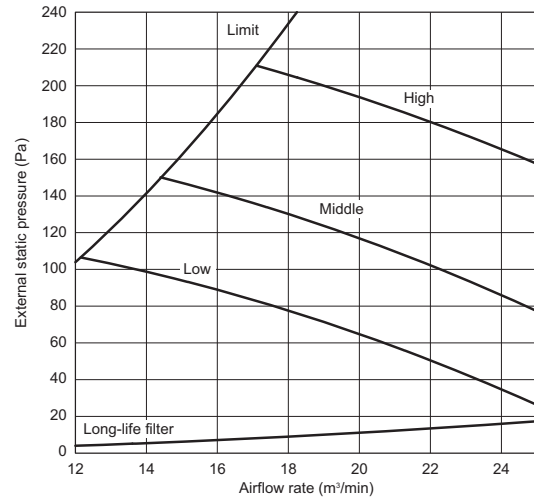

### PEFY-P71VMHS-E

External static pressure : 50Pa  
Power source : 220-240V, 50/60Hz

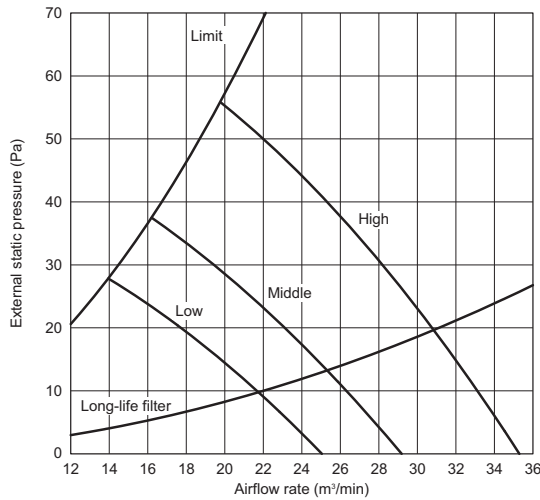

### PEFY-P71VMHS-E

External static pressure : 100Pa  
Power source : 220-240V, 50/60Hz

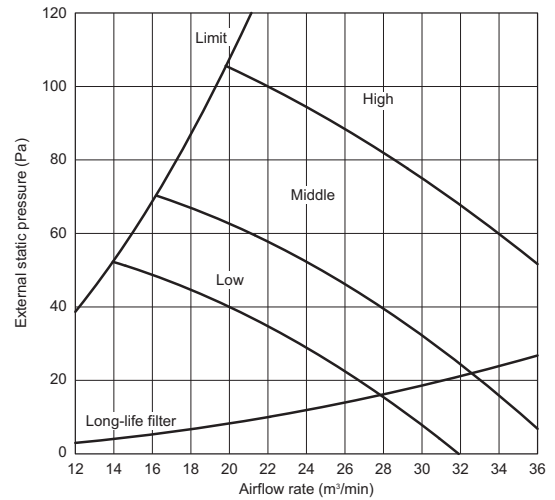

### PEFY-P71VMHS-E

External static pressure : 150Pa  
Power source : 220-240V, 50/60Hz

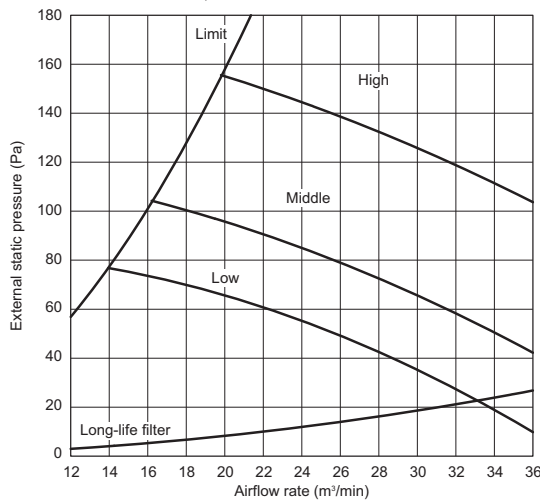

### PEFY-P71VMHS-E

External static pressure : 200Pa  
Power source : 220-240V, 50/60Hz

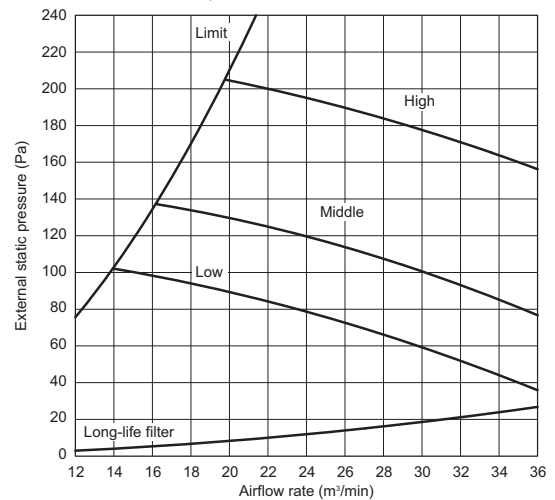

PEFY-P-VMHS-E

## 6. FAN CHARACTERISTICS CURVES

Ceiling concealed (High static pressure type)

PEFY-P-VMHS-E

### PEFY-P80VMHS-E

External static pressure : 50Pa  
Power source : 220-240V, 50/60Hz

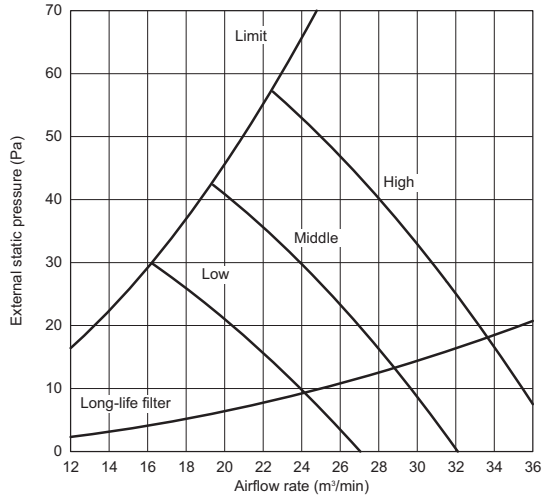

### PEFY-P80VMHS-E

External static pressure : 100Pa  
Power source : 220-240V, 50/60Hz

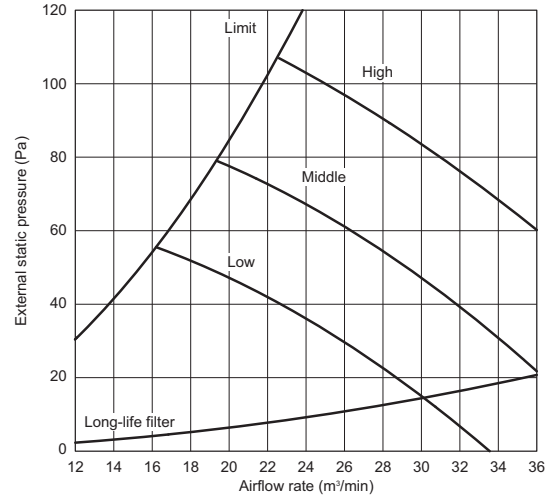

### PEFY-P80VMHS-E

External static pressure : 150Pa  
Power source : 220-240V, 50/60Hz

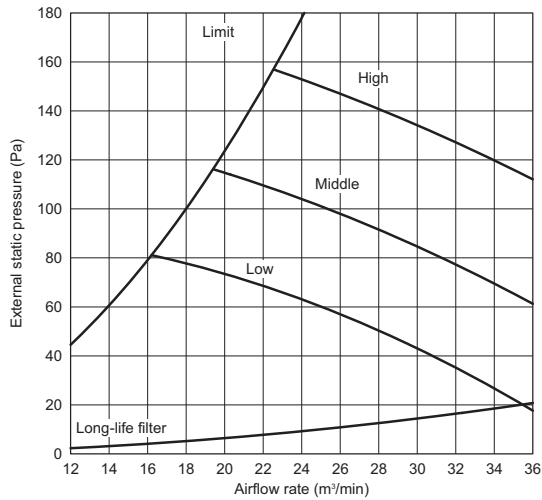

### PEFY-P80VMHS-E

External static pressure : 200Pa  
Power source : 220-240V, 50/60Hz

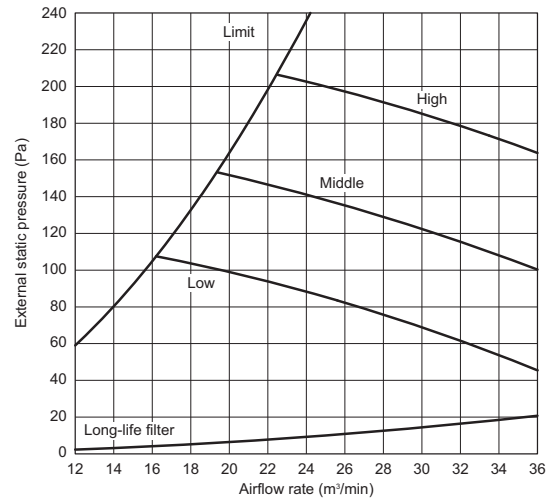

### PEFY-P100, 125VMHS-E

External static pressure : 50Pa  
Power source : 220-240V, 50/60Hz

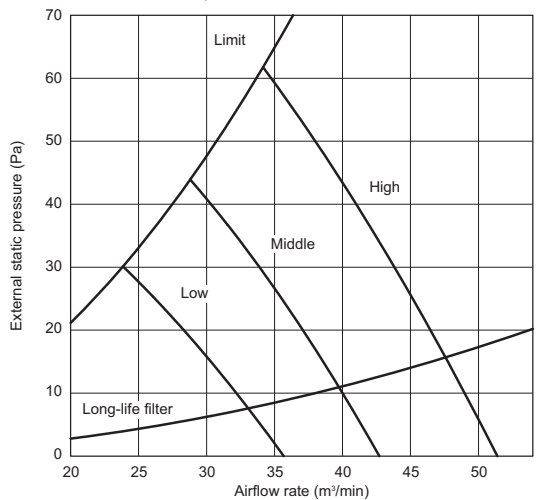

### PEFY-P100, 125VMHS-E

External static pressure : 100Pa  
Power source : 220-240V, 50/60Hz

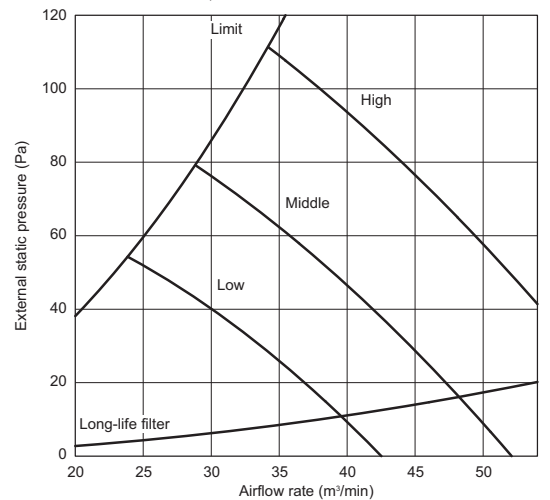

## 6. FAN CHARACTERISTICS CURVES

Ceiling concealed (High static pressure type)

### PEFY-P100, 125VMHS-E

External static pressure : 150Pa  
Power source : 220-240V, 50/60Hz

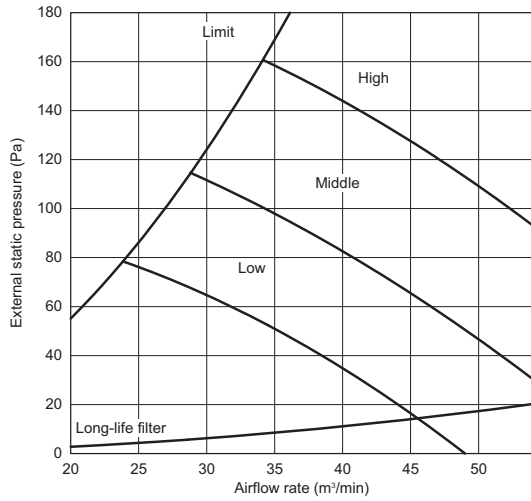

### PEFY-P100, 125VMHS-E

External static pressure : 200Pa  
Power source : 220-240V, 50/60Hz

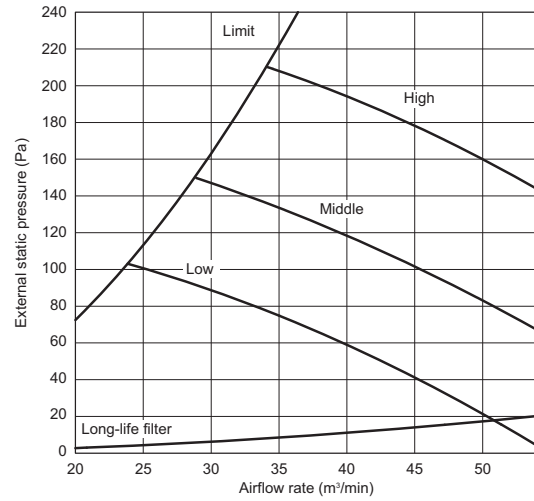

### PEFY-P140VMHS-E

External static pressure : 50Pa  
Power source : 220-240V, 50/60Hz

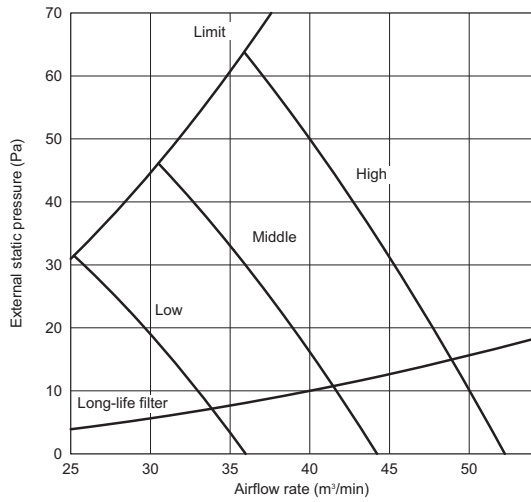

### PEFY-P140VMHS-E

External static pressure : 100Pa  
Power source : 220-240V, 50/60Hz

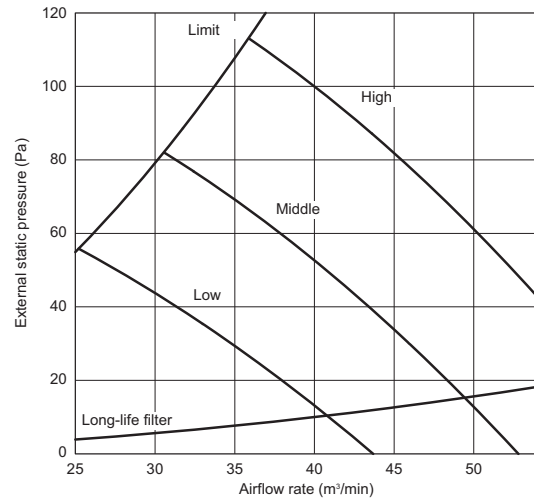

### PEFY-P140VMHS-E

External static pressure : 150Pa  
Power source : 220-240V, 50/60Hz

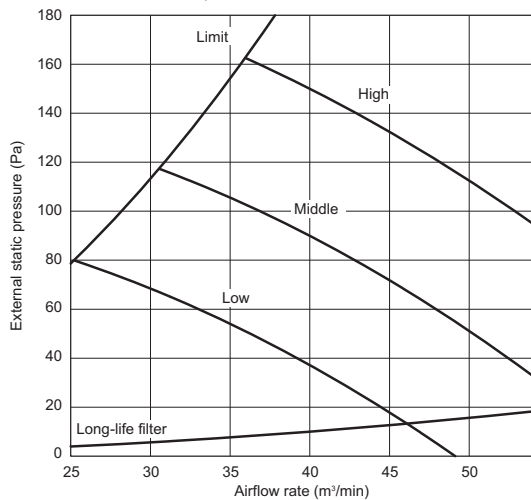

### PEFY-P140VMHS-E

External static pressure : 200Pa  
Power source : 220-240V, 50/60Hz

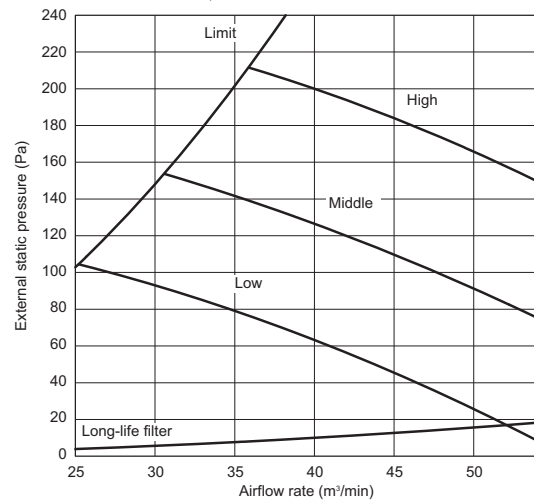

PEFY-P-VMHS-E

## 6. FAN CHARACTERISTICS CURVES

Ceiling concealed (High static pressure type)

PEFY-P-VMHS-E

**PEFY-P200VMHS-E**  
 External static pressure : 50Pa  
 Power source : 220,230,240V, 50/60Hz

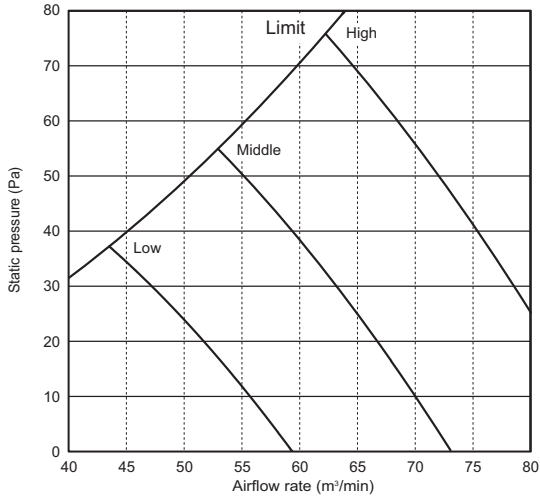

**PEFY-P200VMHS-E**  
 External static pressure : 100Pa  
 Power source : 220,230,240V, 50/60Hz

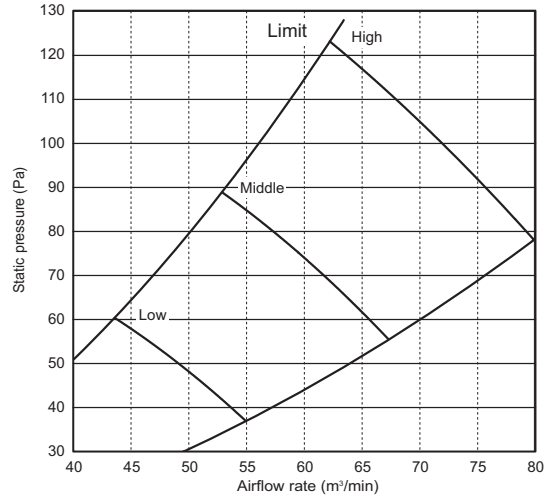

**PEFY-P200VMHS-E**  
 External static pressure : 150Pa  
 Power source : 220,230,240V, 50/60Hz

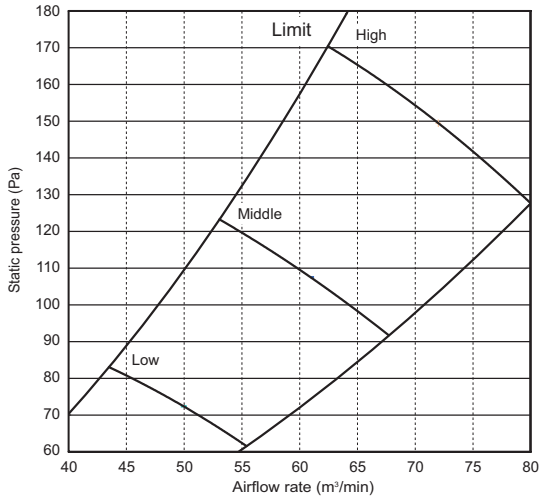

**PEFY-P200VMHS-E**  
 External static pressure : 200Pa  
 Power source : 220,230,240V, 50/60Hz

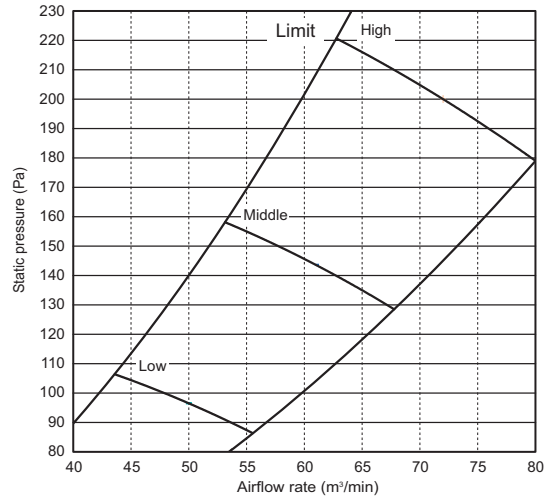

**PEFY-P200VMHS-E**  
 External static pressure : 250Pa  
 Power source : 220,230,240V, 50/60Hz

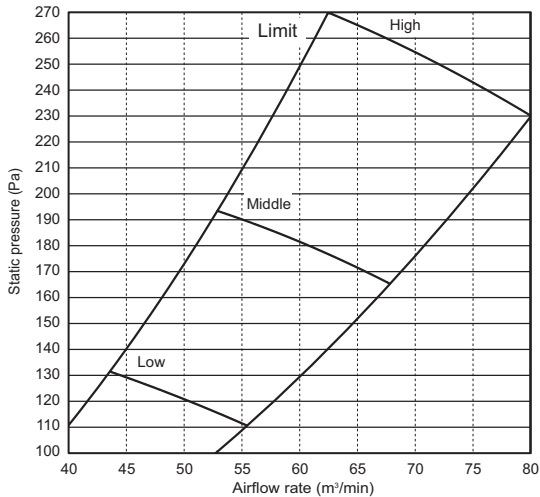

## 6. FAN CHARACTERISTICS CURVES

Ceiling concealed (High static pressure type)

### PEFY-P250VMHS-E

External static pressure : 50Pa

Power source : 220,230,240V, 50/60Hz

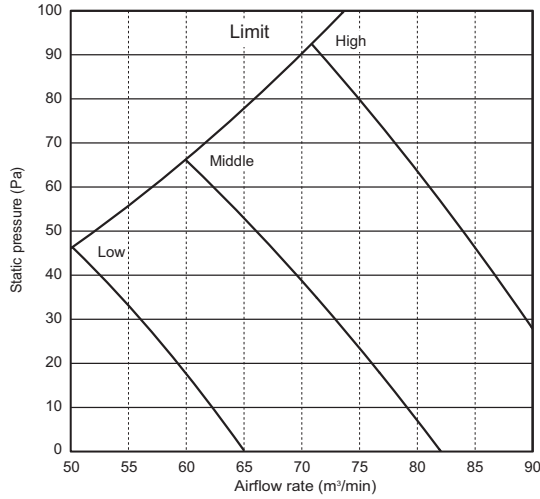

### PEFY-P250VMHS-E

External static pressure : 100Pa

Power source : 220,230,240V, 50/60Hz

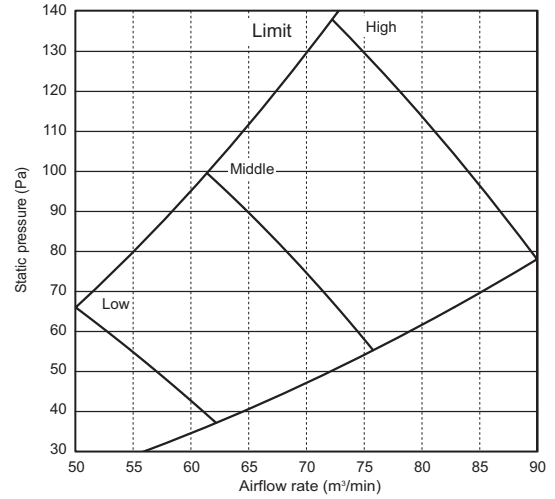

### PEFY-P250VMHS-E

External static pressure : 150Pa

Power source : 220,230,240V, 50/60Hz

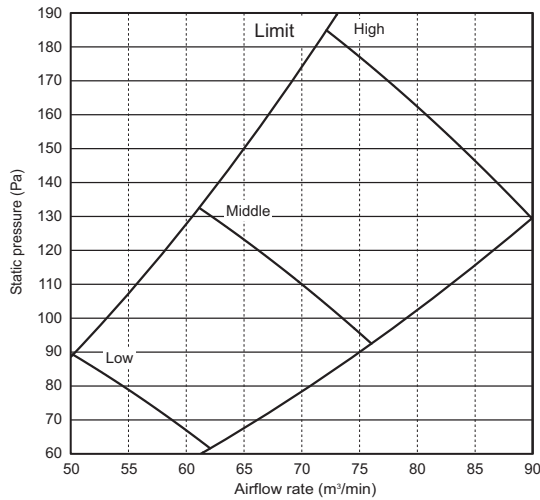

### PEFY-P250VMHS-E

External static pressure : 200Pa

Power source : 220,230,240V, 50/60Hz

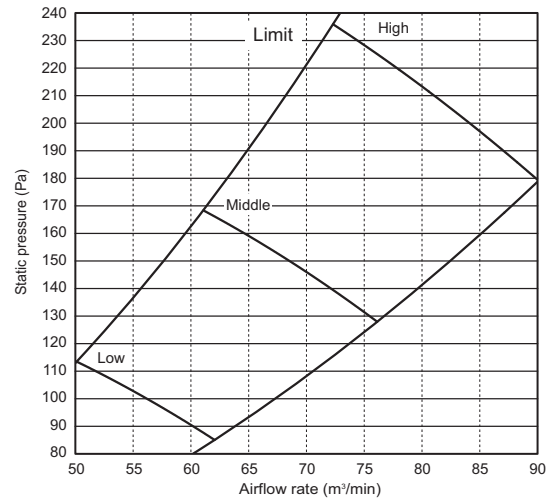

### PEFY-P250VMHS-E

External static pressure : 250Pa

Power source : 220,230,240V, 50/60Hz

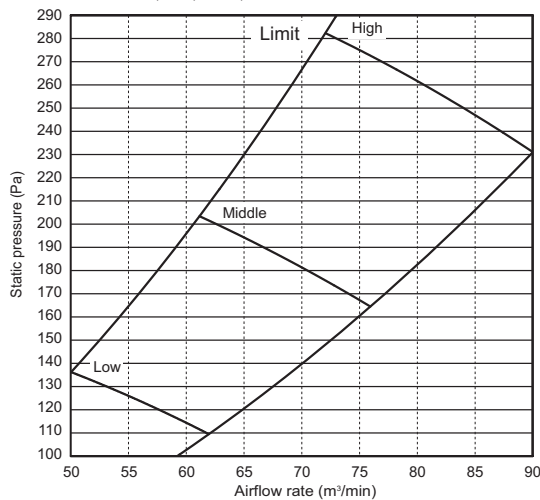

PEFY-P-VMHS-E

## 7. ELECTRICAL CHARACTERISTICS

Ceiling concealed (High static pressure type)

Symbols: MCA (Max.Circuit Amps =1.25xFLA), FLA (Full Load Amps)  
IFM (Indoor Fan Motor), Output (Fan motor rated output)

PEFY-P-VMHS-E	Power supply			IFM	
	Volts/Hz	Range +/-10%	MCA(A) (50/60Hz)	Output (kW)	FLA(A) (50/60Hz)
PEFY-P40VMHS-E	220-240V/50Hz 220-240V/60Hz	Max.: 264V Min.: 198V	1.78	0.121	1.42
PEFY-P50VMHS-E			1.78	0.121	1.42
PEFY-P63VMHS-E			1.97	0.121	1.57
PEFY-P71VMHS-E			2.38	0.244	1.90
PEFY-P80VMHS-E			2.45	0.244	1.96
PEFY-P100VMHS-E			3.85	0.375	3.08
PEFY-P125VMHS-E			3.85	0.375	3.08
PEFY-P140VMHS-E			3.93	0.375	3.14
PEFY-P200VMHS-E			7.00	0.87	5.60
PEFY-P250VMHS-E			7.50	0.87	6.00

PEFY-P-VMHS-E

8-1. Optional parts line up for the Indoor unit

	Long-life filter	Filter box	Drain pump
PEFY-P40, 50, 63VMHS-E	PAC-KE86LAF	PAC-KE63TB-F	PAC-DRP10DP-E2
PEFY-P71, 80VMHS-E	PAC-KE88LAF	PAC-KE99TB-F	PAC-DRP10DP-E2
PEFY-P100, 125, 140VMHS-E	PAC-KE89LAF	PAC-KE140TB-F	PAC-DRP10DP-E2
PEFY-P200, 250VMHS-E	PAC-KE85LAF	PAC-KE250TB-F	PAC-KE05DM-F

PEFY-P-VMHS-E

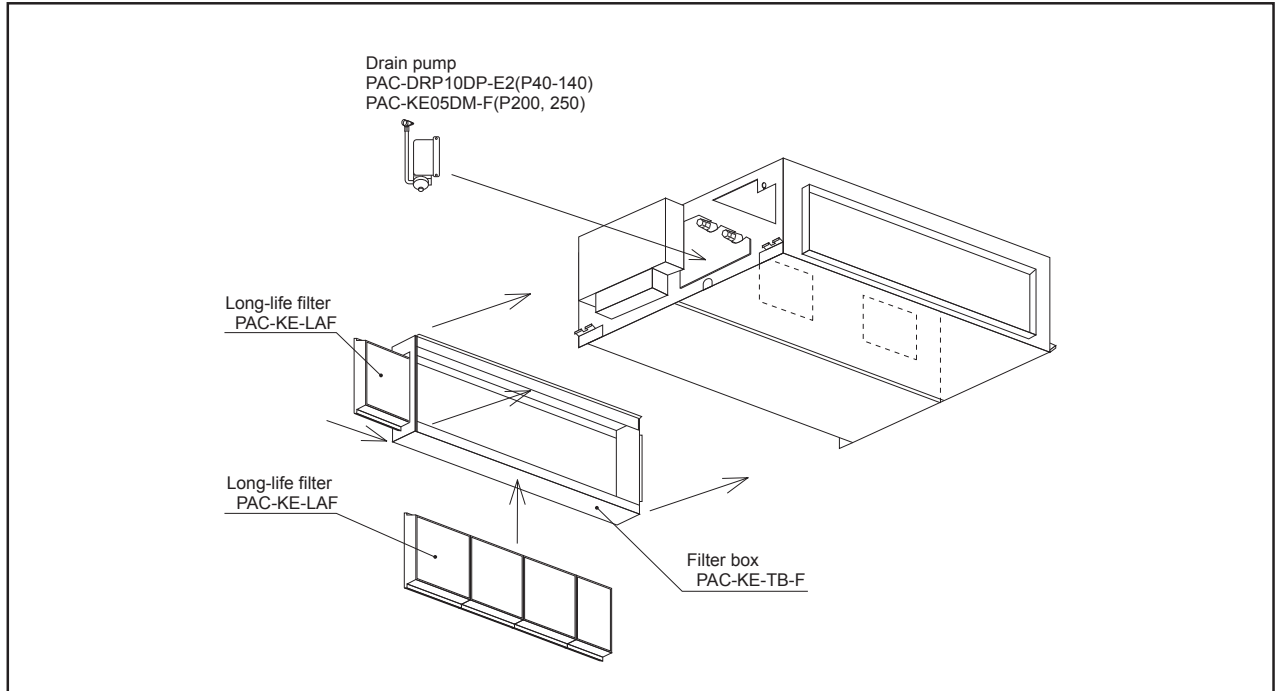

PEFY-P-VMHS-E

8-2. Long-life filter

Life span: 2,500 hr (Dust concentration 0.15mg/m<sup>3</sup>)  
 \* The actual dust situation affects the filter life span, which should be considered at the applying site.  
 Material: Synthetic fiber unwoven cloth filter  
 Static pressure loss is referred to 6 "FAN CHARACTERISTICS CURVES".  
 Long-life filter should be used together with filter box PAC-KE-TB-F.

PAC-KE-LAF

Item	PAC-KE86LAF	PAC-KE88LAF	PAC-KE89LAF	PAC-KE85LAF
Quantity	2	3	3	2
	(298X300)	(298X300)	(298X300)	(411X600)
Shape				

Detailed installation information should be referred to its Installation Manual.

PAC-KE-TB-F



Item	① Screw	② Filter box	③ Installation manual	
Quantity	10/12*	1	1	
Shape				*PAC-KE250TB has 12 pieces of screw.

Detailed installation information should be referred to its Installation Manual.

8-3. Drain pump

If drain water can not flow out the Indoor unit by gravity and gradient, a Drain-pump for draining is needed.  
 Drain pump PAC-DRP10DP-E2 can pump water up to 550mm [21-11/16 in.] high from the drain pan.

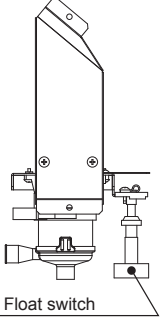
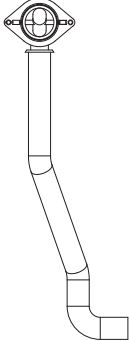
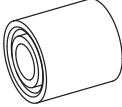
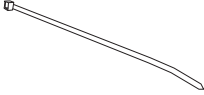



**PAC-DRP10DP-E2**

Item	① Drain pump ass'y	② Drain socket ass'y	③ Rubber plug	④ Band	⑤ PTT screw 4 × 10
Quantity	1	1	1	3	2 + 1 (spare)
Shape					

Detailed installation information should be referred to its Installation Manual.

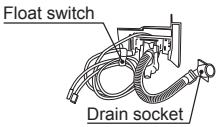
If drain water can not flow out the Indoor unit by gravity and gradient, a Drain-pump for draining is needed.  
 Drain pump PAC-KE05DM-F can pump water up to 700mm [27-9/16 in.] high from the drain pan.

**PAC-KE05DM-F**

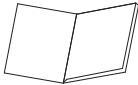
Item	① Drain pump ass'y	② Rubber plug	③ Rubber bushing	④ Band	⑤ PTT screw 4X10
Quantity	1	2	1	2	6+1 (spare)
Shape					
Item	⑥ Installation manual				
Quantity	1				
Shape					

Detailed installation information should be referred to its Installation Manual.

PEFY-P-YMHS-E