

Climaveneta **Data Book**

WSM2_0052_0092_201906_EN

WSM2 / WSM2-T

0052 - 0092
15,8 - 27,4 kW

Reversible Air cooled Rooftop unit,
fully Configurable and high Efficiency



(The photo of the unit is purely indicative and may vary depending on the model)

- Maximum flexibility
- Minimum footprint
- High versatility
- Thermodynamic heat recovery



CERTIFICATIONS

Product certifications



System certifications



Climaveneta S.p.A.:

Quality System complying with the requirements of UNI EN ISO9001:2008 regulation

Environmental Management System complying with the requirements of UNI EN ISO14001:2004 regulation

SUMMARY

1. LEED RELEVANT PRODUCT	pg. 4
2. PRODUCT PRESENTATION	5
3. MAIN COMPONENTS	6
4. DESCRIPTION OF THE UNIT	9
5. ACCESSORIES	13
6. GENERAL TECHNICAL SPECIFICATIONS	17
7. OPERATING LIMITS	25
8. DIMENSIONAL DRAWINGS	27

The units highlighted in this publication contain HFC R410A [GWP₁₀₀ 2088] fluorinated greenhouse gases.

Waiver of liability

This publication is the sole property of MEHITS S.p.A. Any reproduction or disclosure of such is strictly prohibited without the written authorisation of MEHITS S.p.A.

This document has been prepared with maximum care and attention paid to the content shown. Nonetheless, MEHITS S.p.A. waives all liability deriving from the use of such document.

Read this document carefully.

All work must be performed, components selected and materials used professionally and in complete accordance with the legislation in force in material in the country concerned, and considering the operating conditions and intended uses of the system, by qualified personnel.

The data contained in this publication may be changed without prior notice.

1. GREEN CERTIFICATION RELEVANT

Mitsubishi Electric Hydronics & IT Cooling Systems S.p.A., as a major player in the world HVAC market and a leading manufacturer of energy efficient, sustainable HVAC solutions, recognizes and supports the diffusion of green certification systems, as an effective way to deliver high performance buildings and improve the quality and the sustainability of the built environment.

Since the first certification system was introduced at the beginning of the 1990s, the demand for certified buildings has grown considerably, as well as the number of standards, rating and certification programs.

Operating worldwide Mitsubishi Electric Hydronics & IT Cooling Systems S.p.A., has extensive experience with many of them and is active member of Green Building Council Italy.

Mitsubishi Electric Hydronics & IT Cooling Systems S.p.A., commitment to develop responsible and sustainable HVAC solutions, is reflected by a full range of premium efficiency products and systems, designed with special care to improve building energy performance ratings, according to major certification protocols, including LEED, BREAM, GREENSTAR, BCA, NABERS, DNGB, HQE and BEAM.

To find out more about how our products contribute to enhanced green certification rating and energy performance of a building, please refer to:

<https://www.melcohit.com/GLOBAL/Company/Green-Certifications/QR%20code/>



2. PRODUCT PRESENTATION

The WSM2 units are packaged reverse-cycle air-to-air units specifically designed for installation in small to medium-sized spaces, such as shops, bars and service stations.

As a result of MEHITS's extensive experience in the design and development of rooftop units, these appliances are an extension of the Packaged system offering and part of its plan to rationalise the range.

According to the selected version, these units provide complete air handling and ventilation in the air-conditioned ambients, with a flexible and versatile packaged solution that optimises the system and simplifies installation.

The units can moreover be customised to adapt to different types of environments, with various different accessories available. The right unit can therefore be chosen for each system, offering a simple and reliable response to all installation requirements.

The unit is intended for outdoor installations.

2.2 Maximum flexibility

Maximum freedom in choosing the direction of air flows, both supply and return, means the units can be adapted to all installation contexts.

The building's constructional limits can therefore be overcome, offering a highly flexible solution.

In addition, ducting installation is much easier, as there are no restrictions in unit layout regarding the position of the supply and return duct connections.

2.3 Minimum footprint

For applications in small-medium areas, spaces available for unit installation are often quite limited and consequently the units themselves must be as compact as possible.

The WSM2 packaged solution is the ideal solution, as just one compact unit comprises everything needed for room air-conditioning, replacing bulkier and more expensive solutions that use separate units for chilled fluid production and air handling. Maximum care has been paid to the unit's structural design, making sure flexibility, sturdiness and complete functions can all be guaranteed in minimum dimensions.

2.4 High versatility

Each application has different needs, all of which require an optimum response.

The WSM2 range of units offer different selection options regarding the air treatment sections, ranging from recirculation only to mixtures of fresh outside and recirculated air, and solutions with heat recovery from the exhaust air.

As well as this, each of the different configurations can be further customised thanks to a vast selection of accessories.

2.5. ErP Directive



The unit meets the requirements for seasonal energy efficiency in heating mode ($\eta_{s,h}$) and cooling mode ($\eta_{s,h}$) pursuant to Regulation (EU) 2016/2281, First Tier.

2.6. Certificazione Eurovent



The WSM2 range is part of the Eurovent certification program for rooftop (RT) units. The list of certified products is available on the website www.eurovent-certification.com

3. CARATTERISTICHE PRINCIPALI

3.1 AIR 3000 TE advanced controller

All units are fitted with the AIR 3000 TE controller, especially developed by MEHITS S.p.A. for rooftop units. It features a double control board, one for the refrigerant circuit and one for the air treatment, and a liquid crystal display (LCD) on board of all the units.

This keypad accesses a user interface with eighteen European languages available for selection by the user. This allows an interface that's specific for the country where the unit is installed, or alternatively, by setting English, completely independent for all other regions.

Temperature control is performed using algorithms that control available devices (compressors, hot gas reheat coil, heating devices) based on the unit configuration. Control is applied using the return air temperature probe reading, based on proportional or proportional + integral logic. As an alternative also supply temperature control is available. The temperature set point can be set directly on the controller, or managed via a remote digital or analogue contact.

Interfacing to commercially-available BMS systems is provided thanks to compatibility with BACnet, BACnet OverIP, ModBus and LonWorks protocols.

The **built-in clock** provides a daily scheduler function, organized into time bands so as to optimise unit operation, minimizing system energy consumption.

In fact, several time bands (up to 10) of different types (4) can be activated throughout the day, with each band being assigned:

- temperature set point for cooling and heating
- humidity set point
- unit operating modes: control on, off, purging, start-up.

Ventilation, according to unit's configuration, can be managed in the following modes:

- constant air flow;
- constant pressure;
- variable air flow.

Other available functions:

- room humidity control in cooling and heating mode;
- automatic temperature- and enthalpy-based free cooling Management;
- self-adaptive defrost management using algorithms that reduce defrost duration or prevent unnecessary or wasteful cycles;
- demand limit on compressors to reduce mains power consumption;
- set point compensation based on outside temperature, in both cooling and heating operation;
- compressor unloading, assisted by activation of outside air damper;
- Management of the heating devices as integration or substitution of the heat pump;
- Control and management of the ambient air quality with on board sensors or remote signal;
- Air flow set point management with digital or analog signal;
- Auxiliary controls available through remote contact or directly from the controller: room washing mode, running-up mode, ventilation mode, full fresh air mode.



Display and acquisition of the last 200 alarm events (user level) are also available as well as recording of operating variables in the 10 minutes prior to each alarm event (assistance level through Black Box) with display via PC. Compatibility with remote keypad (management of up to 8 units).

3.2 Complete range

The WSM2 range comes in 4 sizes, with three different versions available to satisfy all system requirements, being supplied with a complete set of standard components and a comprehensive selection of accessories.

All the units are with single refrigerant circuit and two tandem scroll compressors.

The units use plug fan on both the supply and return. Supply fan available static pressure, on standard units, guarantees a wide operating range.

The availability of different filtering options ensures the best response to the specific requirements of each installation: the maximum air quality can be achieved to measure, using ISO coarse 50% filtration degrees (ISO 16890 - G4 EN779) combined with plate filter filters with pockets type ePM01-50% (ISO 16890 - F7 in accordance with EN 779: 2012) or ePM01-80% (ISO 16890 - F9 in accordance with EN 779: 2012).

The reverse-cycle refrigerant circuit and free cooling/free heating operation allow continuous service within the wide range of operating limits, achieved through careful sizing of the components and specific design choices.

Thanks to the standard equipment for external air high temperature, the units are suitable to work in cooling mode with high external air temperatures, for installation in hot climates.

3.3 Simplified installation and maintenance

The WSM2 rooftop units simplify and reduce the costs of maintenance and work on site, through:

- Sturdy and perfectly insulated structure that guarantees resistance to the elements and mechanical stress.
- Easy access to the inside sections and the components that require periodical cleaning, for fast and economical routine maintenance.
- "PLUG and PLAY" construction that ensures, once the unit has been positioned, simpler and faster electrical and air connections.
- Automatic calibration of air flow-rates, with consequent savings in technical service and greater comfort.

3.4 Plug fan

WSM2 units are supplied with plug fans with EC brushless motor. These fans differ from traditional centrifugal fans due to absence of the scroll and direct coupling to the motor, thus eliminating energy loss from the belt and pulley transmission. The rotor is realized with high performance composite material that enhances the efficiency and reduces the noise.



This type of technology ensures clear advantages, with installation being simplified based on the parameters set by the user, without needing any flow-rate adjustment during calibration. In addition, fan speed adapts to the characteristics of the system even when the unit is operating, for example compensating for any variations in flow-rate due to progressive fouling of the filters. The low power consumption of these types of fans can be further reduced by applying the exclusive control logic developed by MEHITS S.p.A. All this means high operating efficiency even for the part involving the fans, traditionally a critical area in terms of running costs.

3.5 Variable Air Flow

On rooftop units, that directly serve the air-conditioned environment and represent the main source of ventilation, the supply and return fans work continuously at a fixed flow-rate, in all operating conditions, even during freecooling and at part loads, which together account for the majority of operating hours.

Consequently, power consumption from fan operation on rooftop units represents over 50% of total annual unit power consumption, which is why MEHITS S.p.A. decided to develop a system for controlling fans that could reduce fan power consumption.

The most effective way to reduce power consumption is to decrease fan speed, and consequently flow-rate, whenever system operating conditions allow.

The advanced logic featured on the AIR 3000 TE controller and the use of plug fans with electronic speed control have allowed the **Variable Air Flow** function to be developed. This involves changing the supply and return air flow-rate based on effective demand from the system, considering the activation percentage of each device - compressors, heaters or burners, freecooling or freeheating. For example, progressive shutdown of the compressors will bring a reduction in air flow-rate, defined within the limits set by the user.

This means flow-rates are managed based on the actual conditions in the air-conditioned space, while still observing any limits defined on the components and the type of system. In addition to benefits in terms of comfort, there are also economic advantages, as reducing fan speed cuts total unit power consumption by 30% compared to the traditional fixed flow-rate solution.

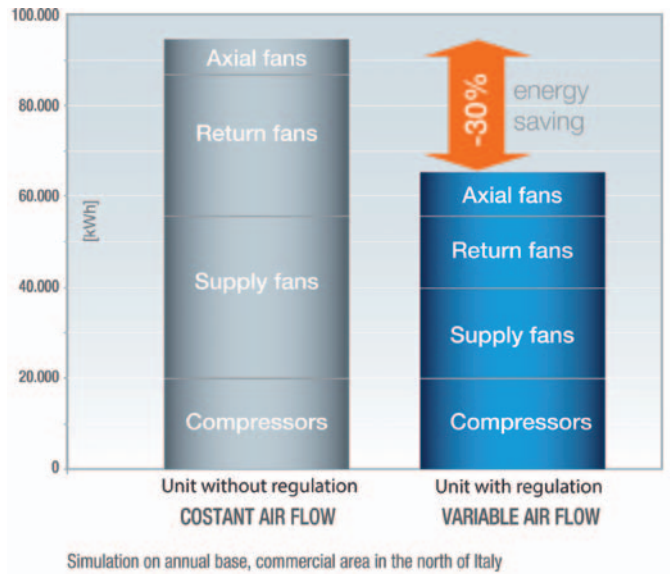
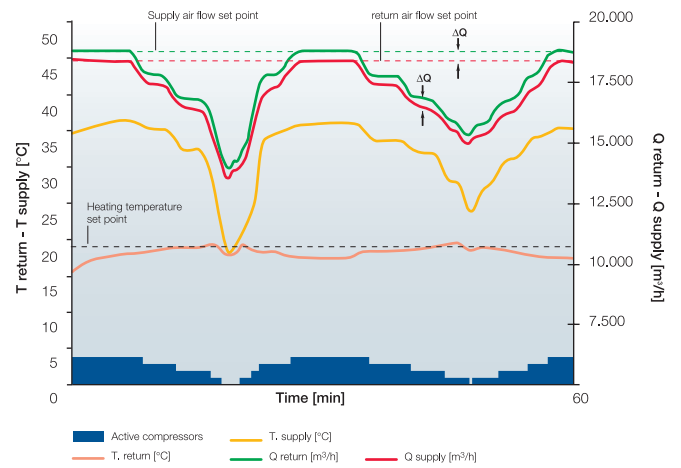

4. DESCRIPTION OF THE UNIT

4.1 Description

Packaged reverse-cycle air-cooled rooftop air-conditioner with scroll compressor and R410A refrigerant

Packaged air-cooled rooftop air-conditioner, reverse-cycle (WSM2) or cooling-only (WSM2-T), for outdoor installation, for air handling, filtration and ventilation, based on the selected configuration.

The WSM2 and WSM2-T units are part of the Eurovent Certification program for rooftop (RT) units; the list of certified units is available at www.eurovent-certification.com.

The units can work at full load across a very wide range of operating temperatures (for outside coil down to -15°C in heat pump mode and up to +48°C in cooling mode; indoor coil air inlet down to -6°C in heat pump mode and up to +40°C in cooling mode).

Structure

Structure designed specifically for outdoor installation, base and load-bearing frame made from suitably thick hot galvanised and painted steel sections. The front of the unit comprising the condenser and the electrical panel is made from galvanised metal panelling, painted with polyester powder coat to ensure complete weather resistance (colour RAL 7035).

The air handling section comprises a load-bearing structure made completely from aluminium alloy, supporting sandwich panels (thickness 25 mm on the side, 42 mm bottom and top), with galvanised sheet panelling on the inside and painted galvanised sheet (colour RAL 7035) on the outside, with polyurethane foam insulation in between, average density 45 kg/m³.

The resulting structure has the following features:

1. rigidity and sturdiness;
2. continuous gasket on the closing panels in the air handling area for better tightness to air and rainwater;
3. panels closed using special handles that allow them to be opened from the left or right or removed completely, for better access to the unit;
4. the sandwich panels making up the top of the air handling area are in turn fully covered by special coiled metal panelling to prevent water infiltration; this panelling is made from galvanised and painted sheet, colour RAL 7035;
5. the electrical cables and refrigerant piping are positioned in dedicated sections, without crossing through the air handling section.

Any mixing chambers for air return, energy recovery or additional modules are always incorporated into the single packaged structure; the WSM2 unit is therefore a completely plug-and-play solution, minimising the time needed for handling and installation on site.

Compressors

Hermetic rotary scroll compressors, R410A refrigerant, fitted with timed crankcase heater (automatically deactivated when not needed) and a two-pole electric motor with direct starting, internally protected against excess temperature.

The compressors are housed in a condensing compartment, with the bottom surface designed to collect and drain water from defrosting, preventing ice from forming on the base.

Outdoor heat exchanger

Direct expansion outdoor coil for heat exchange between the refrigerant gas and the outside air, made from a coil of mechanically expanded copper tubes and corrugated aluminium.

Refrigerant circuit

The unit has one refrigerant circuit comprising, in addition to the above:

- R410A refrigerant charge
- filter-drier
- liquid flow indicator
- bi-directional electronic thermostatic expansion valve
- charge and pressure control valves
- low pressure safety valve
- high pressure switch
- double high pressure safety valve (protects the unit against explosion in the event of fire)
- non-return valve
- four-way reversing valve

Air handling Plug fans

Supply plug fans with brushless EC motors. Three-dimensional profiled blades made of high performance composite material, optimized to enhance efficiency and reduce noise. EC brushless electric motor, directly coupled with electronic speed adjustment for the precise and continuous regulation of the air flow rate.

Outdoor fans

Electrically commutated axial fans (EC fans). The brushless motor, governed by a special controller, continuously adjust fans speed. In this way energy consumption is reduced and current's absorption during start-up phase is minimized, while air flow rate is adjusted continuously according to load and outdoor temperature.

Exhaust air fan (Accessory)

If the unit is equipped with the accessory AX-F function, it is fitted with one or more EC plug fans and a barometric relief valve, that are necessities to help discharge the exhaust air from the air-conditioned space, to balance the fresh air intake.

The expulsion EC plug fan(s) modulates its speed according to fresh air damper opening.

Filtration

Pleated synthetic fibre pre-filter, grade isocoarse 50% (ISO 16890 - G4 EN779), 98 mm thick at the air inlet.

The filters are positioned on steel guides with easy access for routine maintenance and replacement.

Following system commissioning, the filters should be replaced to eliminate any trapped impurities.

Power and control electrical panel

Power and control electrical panel built in compliance with EN60204-1 and IEC204-1, complete with:

- Control circuit transformer
- Main door lock disconnect switch
- Power section with cables
- Fuses and contactors for compressors and fans
- Spring-loaded terminals on the control circuits
- Electrical panel for outdoor installation, with seal gaskets
- AIR 3000 TE microprocessor-based electronic controller
- Operator panel with LCD interface, protected from solar radiation by a painted galvanized steel panel
- Compressor crankcase heaters with timer

Unit power supply voltage: 400V~ ±10% - 50Hz.

Electric panel is supplied as standard with a flexible duct that connect supply air treatment side with the electric panel. In this way, electrical panel is cooled during summer and heated in winter time, reducing the problem of condensation on electrical device.

AIR 3000 TE controller

The AIR3000 TE controller offers advanced functions and algorithms. It is made up by two control boards, dedicated to the air side and the refrigerant side respectively. The keypad features functional controls and a complete LCD display that allows for the monitoring and intervention on the unit by means of a multi-level menu with selectable user's language.

It can be used to set the unit start-up and ambient washing function, as well as to set unit the operating mode (manual heating or cooling, automatic changeover).

Temperature control is based on proportional or proportional + integral logic using the return air temperature probe reading; the set point can also be adjusted based on the outside temperature, in both cooling and heating mode.

For units fitted with motorised outside air damper, the controller automatically manages free cooling operation based on the outside air temperature; optionally, free cooling can also be managed based on enthalpy.

As an option, constant air flow, variable air flow, constant pressure air control are available to manage the fans.

The controller can also integrate and automatically manage different optional heating devices (hot water coil, electric heater and built-in gas-fired heating module), hot gas post-heating (optional) and percentage of fresh air (optional via CO₂ probe or remote 4-20 mA signal).

Defrosts use proprietary self-adaptive logic involving monitoring of multiple operating and climate parameters.

This reduces the number and duration of defrosts, consequently increasing overall energy efficiency.

Compressor power consumption can be controlled using the demand limit function, while the unloading function is available for part-load refrigerant circuit operation in critical conditions.

Supervision is available with different options, using proprietary devices or by integration into third party systems using ModBus, BACnet, BACnet-over-IP and Echelon LonWorks protocols.

Compatibility with remote keypad (management of up to 8 units).

The timer can be used to create an operating profile with up to 4 typical days and 10 different time bands.

Certification

Unit compliant with the following directives and amendments:

- Machinery directive 2006/42/EC.
- Electromagnetic compatibility directive 2014/30/EC.
- Pressure equipment directive 2014/68/EU
- Low voltage directive 2014/35/EC.
- Gas appliances directive 2009/142/EC (where applicable)
- Regulation (EU) 2016/2281 (implementation of directive 2009/125/EC) second Tier (ErP 2021).
- Eurovent certification (www.eurovent-certification.com) - rooftop unit program (RT)

4.2 Functions

AR function - Air recirculation (Basic unit)

Unit developed for 100% recirculated air operation only. The unit extracts air from the ambient and inflows it back after air treatment using internal coil. Ambient air expulsion and air renovation must be managed using systems that are separate from the rooftop unit.

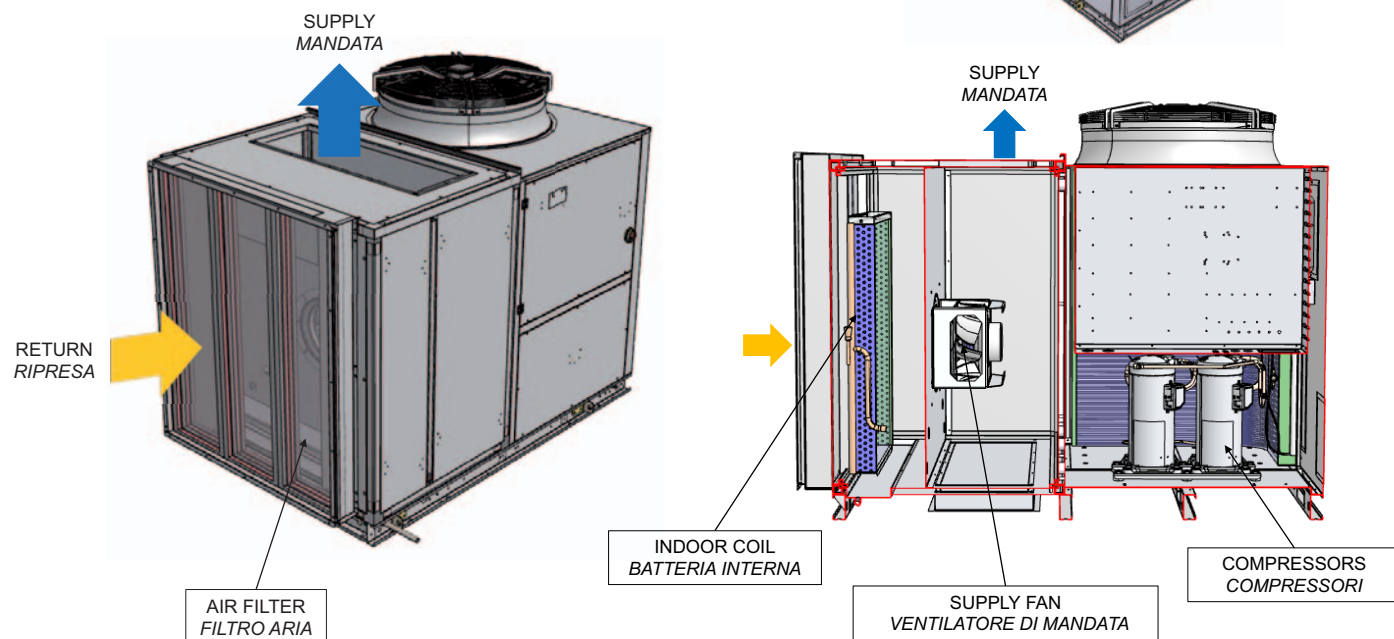

Opt. 1072 - MF function - Mixing and Free cooling

Compared to the basic version, the unit features two opposing motorised dampers managed by the unit's controller so as to allow operation with 100% recirculated air, mixtures and free cooling. This function allows the recirculated ambient air to be mixed with some fresh outside air, either at a fixed percentage set on the controller, or using an air quality probe (CO2 reading). Free cooling operation is managed by the controller, which opens the dampers so as to create a mixture of fresh outside air and recirculated air that requires less energy for the treatment,

depending on the outside temperature, indoor temperature and set point. During this function one or more cooling devices are disconnected, and are completely switched off with total free cooling operation. The supply fans guarantee rated air flow; ambient air expulsion must be managed using systems that are separate from the rooftop unit. This function should be chosen when the amount of fresh outside air to be introduced into the spaces is quite low, pressure drop in the return ducts is also low and the building is not particularly airtight (older constructions).

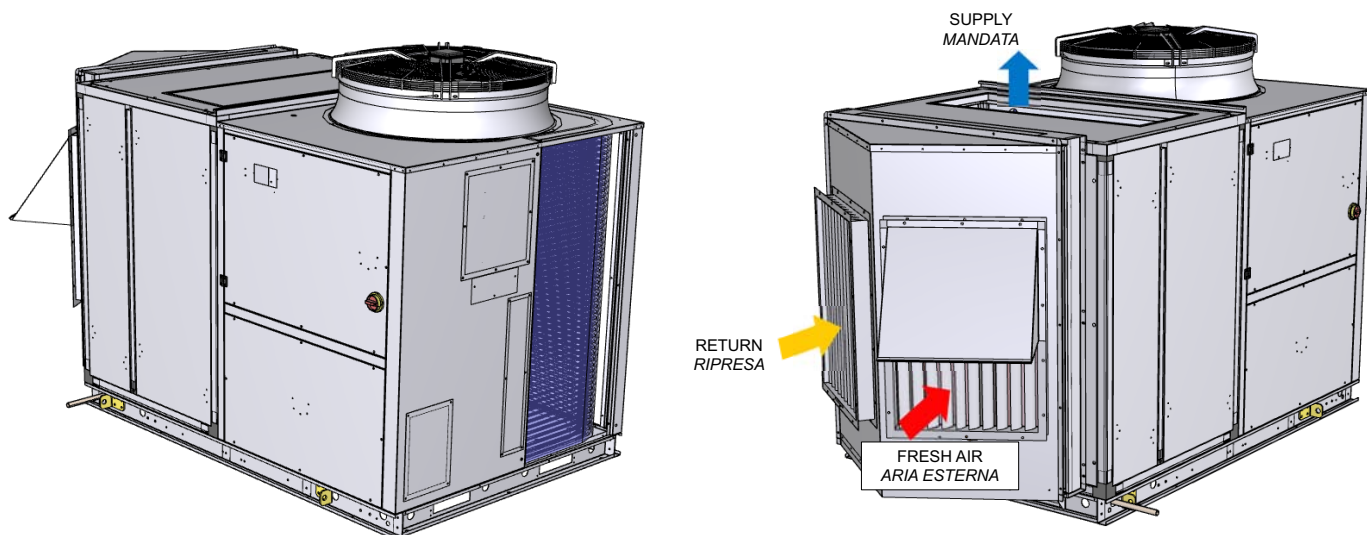

Opzione 1073A - Funzione AX-F - Fan for Extraction + Heat Recovery Free (Mix and exhaust with heat recovery-free)

Compared to the basic version, the unit features two opposing motorised dampers managed by the unit's controller so as to allow operation with 100% recirculated air, mixtures and free cooling.

This function allows the recirculated air taken from the rooms to be mixed with some fresh outside air, either at a fixed percentage set on the controller, or using an air quality probe (CO2 reading). Free cooling operation is managed by the controller, which opens the dampers so as to create a mixture of fresh outside air and recirculated air that requires less energy to air-condition, based on the outside temperature, indoor temperature and set point. During this function one or more cooling devices are deactivated, and are completely switched off with total free cooling operation. The supply fans guarantee the design flow-rate. A barometric damper is fitted on the exhaust air flow so as to minimise the overpressure in the building caused by the introduction of fresh outside air. This damper guarantees quite good control of indoor pressure when introducing small percentages of outside air (up to around 20% of total air flow).

To assist the discharge of exhaust air with higher outside air intake flow-rates, one or more fans are fitted downstream of the barometric damper, and switch on when the amount of outside air introduced exceeds a certain set value.

With reference to the exhaust air flow-rate, these fans can overcome quite high pressure drop in the return air duct, up to 150 Pa. To maximize the energy efficiency, the exhaust fan(s) are plug fan type, with brushless EC motor. The speed is adjusted continuously according to fresh air damper opening.

The supply fans guarantee the design flow-rate, and in the event of high outside air flow-rates (for example, during free cooling or free heating), they can also generate considerable overpressure in the room: in buildings with good air tightness, it is recommended to install an additional extraction system.

Thermodynamic heat recovery: it is achieved by deviating the exhaust air through the outdoor section of the refrigerant circuit; in this way, the air facing to the outdoor coil is milder than the surrounding one, granting a better working conditions to the cooling circuit (decreasing of the condensing temperature in cooling mode and increasing the evaporating temperature in heating mode).

In both cases, the result is an increasing of the cooling/heating capacity and a reduced power absorbed by compressor(s). This type of unit finds application in all those environments of the small medium commercial, characterized by structures with medium air-tightness such as supermarkets, shops and service stations, allowing with a single unit to meet the building's thermal needs and renewal. air.

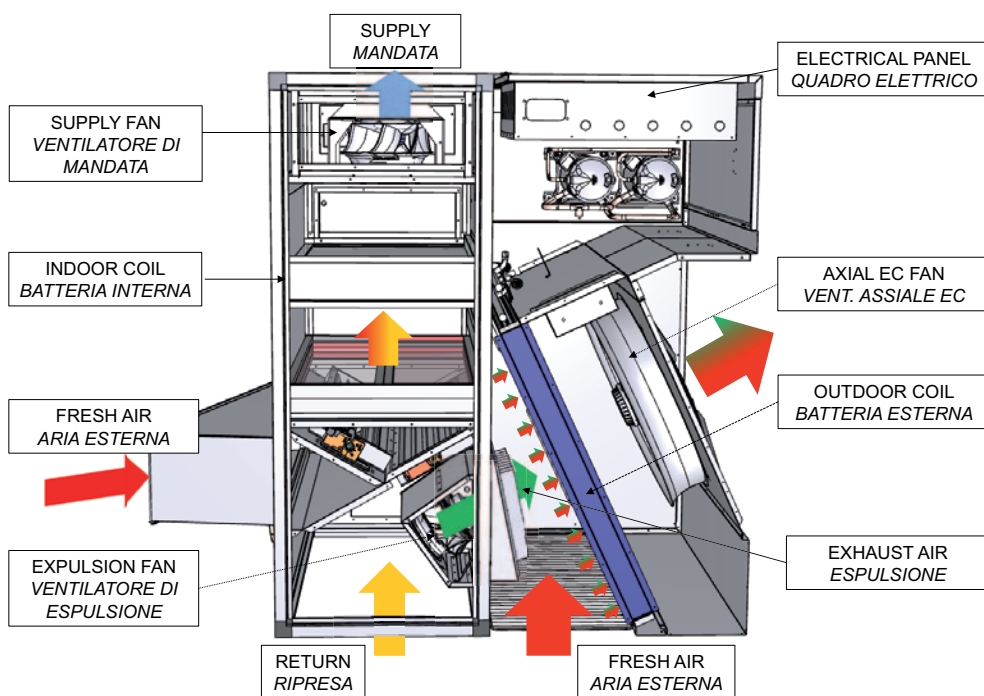
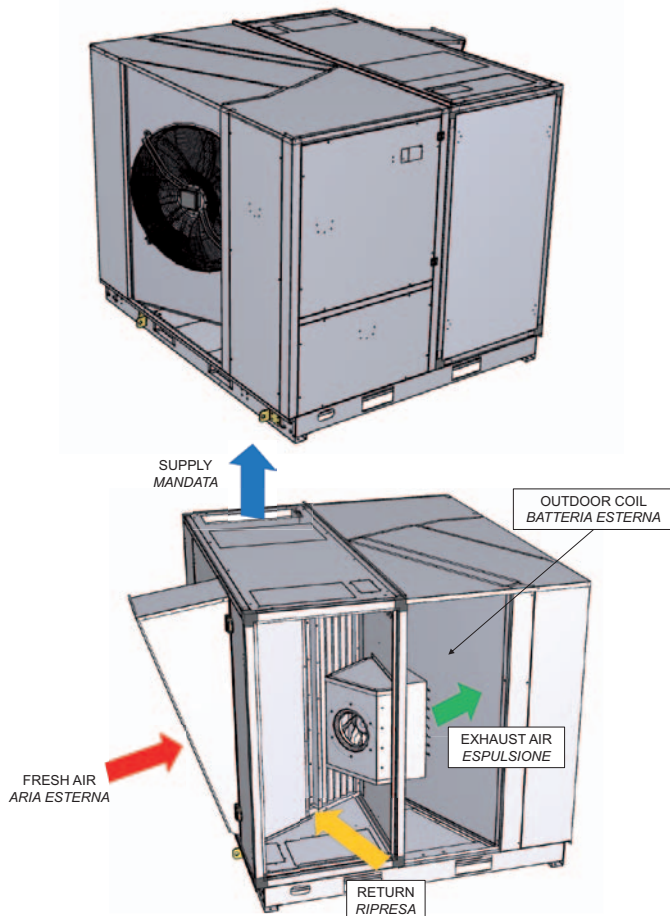

5. ACCESSORIES

CODE	ACCESSORY NAME	DESCRIPTION	ADVANTAGES
1062	Unit ErP 2021 Compliant	This indicates that the unit complies with the minimum seasonal energy efficiency requirements for space heating and cooling specified in EU regulation 2016/2281	The unit fully respect the compatibility directives required for the CE mark, including new efficiency limits in force since January 1st, 2021
2070	Supply air	The supply air flow direction can be chosen among lateral (right), from the bottom the rear or the top. Check compatibility with some accesories and functions on the table reported in this technical bulletin. The reference point is always referred by looking at the unit from the electrical panel	The installation of the unit and the ducts are significantly simplified.
2060	Return air	The return air flow direction can be chosen among lateral (left), from the bottom, the rear or the top. Check compatibility with some accesories and functions on the table reported in this technical bulletin. The reference point is always referred by looking at the unit from the electrical panel	The installation of the unit and the ducts are significantly simplified.
2411	Remote phase-sequence control	Relay for controlling the phasesequence of mains.	Protects loads against faults due to incorrect connection of the electric line.
3412	Automatic circuit breakers	Over-current switch on the major electrical loads.	In case of overcurrent allows resetting of the switch without the replacement of relative fuses.
3301	Power factor correction	Capacitors on the compressors' power inlet line. For the combination with option 1511 (soft start), contact the office.	The unit's average $\cos(\phi)$ increases from an average value of 0,87 to a value (average) of 0,92. For unit size 0052 it's not available, while for unit size 0092 it's not necessary since $\cos(\phi)$ is greater than 0,92.
4181	ModBUS connectivity	Interface module for ModBUS protocols	Allows integration with BMS operating with ModBUS protocol
4182	Echelon connectivity	Interface module for Echelon systems	Allows integration with BMS operating with LonWorks protocol
4184	BACnet connectivity	Interface module for BACnet protocols	Allows integration with BMS operating with BACnet protocol
4185	BACnet OVER IP connectivity	Interface module for BACnet OVER-IP protocols	Allows to interconnect BACnet devices over Internet protocol within wide-area networks
865	EC Axial Outdoor fans	Electronically commutated fans (EC fans). The brushless motor, governed by a special controller, continuously adjust fans' speed.	Reduced energy consumption and minimized current's absorption during start-up phase. The noise reduces proportionally to the unit's partialization.
1511	Soft start	Electronic device adopted to manage the inrush current. For the combination with option 3301 (compressor phase-shifting) contact the office.	Break down of the inrush current compared to the direct motor start, lower motor windings' mechanical wear, avoidance of mains voltage fluctuations during starting, favourable sizing for the electrical system.
4250	Supply fan uprated motor	Increment of the motor electrical power of the supply fans	Increment of the static available pressure at the supply fans outlet
1861	Costant air flow regulation + Vair	The unit can manage the air flow set point, both on supply and return, according to the actual load of the resources.	The reduction of the air flow according to the actual load of the system allows to achieve considerable savings and to increase the efficiency.
1862	Costant air flow regulation	Air fan speed is regulated in order to maintain costant air flow valure.	As pressure drop varies, the fans adjust the speed so as to maintain flow-rate at the design value for the system, regardless of how dirty the filters are. We raccomend to select this option together with Filters differential pressure switch.

CODE	ACCESSORY NAME	DESCRIPTION	ADVANTAGES
1863	Costant pressure regulation	Air fan speed is regulated in order to maintain costant static available pressure value.	Fan speed is controlled in such a way as to maintain a constant available static pressure in the system's air distribution plenum. This is useful for variable air volume (VAV) air distribution systems.
1864	Fixed speed 0-10V	Air fan speed is maintained costant at a fixed value set on display	The fan speed can be set directly in the controler in order to reduce start up procedure.
4411	Supply fans double set point	It is possible to choose a second supply fan set point value, different from that normally set and choose with whom to work via a digital input (set point = could be a fixed air flow or a static pressure or a fixed speed, according to what has been chosen among options 1862-1863-1864). This option is not available with Vair option (1861)	
4413	Supply fans continuous set point variation	Supply fan set point variation is managed through analog input; the set point varies between a minimum and a maximum values previously fixed via unit display (set point = could be a fixed air flow or a static pressure, according to what has been chosen among options 1862-1863-1864). This option is not available with Vair option (1861)	
4141	CO2 air quality probe	Used to manage air quality inside the building. The signal is processed by the control unit in order to adjust the external air intake (signal to the fresh air damper)	Automatic management of the fresh air flow-rate allows outside air to be handled only when needed, guaranteeing compliance with relevant standards and occupant comfort.
4142	External forcing 4-20 mA	Remote forcing with 4-20 mA signal to manage the dampers for air renewal	
2521	High efficiency panel filters, ePM01-50% (ISO16890) - F7 (EN779)	Available in addition to standard filters, they are classified as ePM01-50% (ISO16890) - F7 (EN779) efficiency, made of fibreglass paper and are Class 1 fire resistant. The large inspection panels and steel guides make them easy to remove for cleaning or replacement.	Mounted on the treatment coil inlet, they ensure that the air effectively introduced into the room is filtered.
2521A	High efficiency plate filters, ePM01-80% (ISO16890) - F9 (EN779)	Available in addition to standard filters, they are classified as ePM01-80% (ISO16890) - F9 (EN779) efficiency, made of fibreglass paper and are Class 1 fire resistant. The large inspection panels and steel guides make them easy to remove for cleaning or replacement.	Mounted on the treatment coil inlet, they ensure that the air effectively introduced into the room is filtered.
1852	Filters differential pressure switch	Differential air pressure switch to detect filters' obstruction, with warning	
1461	Hot gas coil with ON/OFF management	Condensing finned coil, installed downstream the treatment coil, fed by hot gas coming from the compressor's supply, with on-off management. For a correct functioning, this option has to be choosen with option dehumidification (opt. 4133-4135-4137)	The hot gas post-heating adjusts supply air temperature during dehumidification phases.
1466	Electric heater management	Option for Electric heater management, that are placed after direct expansion coil. For electric heater capacities, refer to 1312 ÷ 1318.	The electrical heating coil is a heating source which can be used as integration in heat pump working. Furthermore it can be used during defrosting cycles.

CODE	ACCESSORY NAME	DESCRIPTION	ADVANTAGES
1467	2 Rows Water (heating) coil	Water heating coil installed after the internal treatment coil	The coil can be used as a heating source or as integration in heat pump working. Antifreeze function trough opening of the three way valve.
1468	3 Rows Water (heating) coil	Water heating coil installed after the internal treatment coil	The coil can be used as a heating source or as integration in heat pump working. Antifreeze function trough opening of the three way valve.
1341	2 way valve V2V	Modulating mixing valve installed downstream the water heating coil, with modulating drive. This option can be choosen only with water heating coil (opt. 1467 or 1468)	
1342	3 way valve V3V	Modulating mixing valve installed close to the water heating coil, with modulating drive. This option can be choosen only with water heating coil (opt. 1467 or 1468)	
1345	Water coil control continuous signal	It's a continuous signal from controller to manage an external water valve actuator that controls hot water coil flow. This option can be choosen only with water heating coil (opt. 1467 or 1468)	
1312 ÷ 1318	Electrical heating coil	Electrical heater installed after the internal treatment coil. This option can be choosen only with electric heater management (opt. 1466)	The electrical heating coil is a heating source which can be used as integration in heat pump working. Furthermore it can be used during defrosting cycles.
4131	Ambient humidity probe	Probe to measure relative humidity percentage in the ambient, intalled on the return	
4132	Enthalpic Free cooling	Function manged by temperature and humidity probes, installed in a position allowing them to check and compare the energy status of both the ambient and the external air. The control manages the opening/closing of the dampers in order to exploit more favourable external conditions.	During Free cooling functioning, the resources are progressively disconnected, till complete switch off, keeping the required termo-hygrometric ambient condition, thanks to the external favourable conditions
4133	Dehumidification	Thanks to a humidity probe, this function reduces during cooling mode the excess of humidity of the indoor air	Enthalpic control to mantain the ambient humidity to wellbeing values. It's reccomended to use hot resource to post-heating supply air temperature during dehumidification phases.
4134	Signal for humidifier	The unit provides a signal for driving a humidifier, thanks to the reading of the humidity probe placed on reurn side.	Adjustment of relative humidity in winter mode
4309A	Continuous signal for humidifier control	The unit provides an analogic signal for driving a humidifier, thanks to the reading of the humidity probe placed on reurn side.	
881	Cu/Cu condensing coils	Air-refrigerant heat exchanger with copper fins and tubes.	Recommended for applications in corrosive atmospheres
883	Condensing coils with epoxy-coated fins	Painted air-refrigerant heat exchanger.	Recommended for applications in medium level pollution atmospheres.
884	Condensing coils with Electrofin treatment	The outdoor coil is trated with a factory-applied electro-deposition coating process that guarantees complete heat exchanger coverage	Recommended for marine exposure conditions, with an high level of pollution or other aggressive atmospheres.
895	Condensing coils with Fin Guard Silver treatment	Air-refrigerant heat exchanger with epoxidic treatment on coils and fins.	Recommended for marine exposure conditions, with an high level of pollution or other aggressive atmospheres.
2032	Welded mesh protection coil	Welded mesh protection coil	These grills protect outside coil and part of the refrigerant circuit against the intrusion of solid bodies with medium large dimensions.

CODE	ACCESSORY NAME	DESCRIPTION	ADVANTAGES
971	Cu/Cu internal coil	Internal air treatment coil with copper fins and tubes.	Recommended for applications in corrosive atmospheres
974	Internal coil with Fin Guard Silver treatment	Internal air treatment coil with epoxidic treatment on coils and fins.	Recommended for marine exposure conditions, with an high level of pollution or other aggressive atmospheres.
975	Internal coil with prepainted fins	Internal air treatment coil with prepainted fins	Recommended for applications in medium level pollution atmospheres.
976	Internal coil with Electrofin treatment	The indoor coil is trated with a factory-applied electro-deposition coating process that guarantees complete heat exchanger coverage	Recommended for marine exposure conditions, with an high level of pollution or other aggressive atmospheres.
381	Numbered wiring on electric board	During the execution of the electrical panel, in addition to identifying the individual inputs and outputs, eletrric cables are labeled for easier recognition.	Increase the usability of the electrical panel during maintenance.
382	PWR wirings according to Uk request	Power cables with coloring according to the U.K. standards.	
3591	Fans operating signal	Auxiliary contacts providing a voltagefree signal	Allows remote signalling of fans' activation or remote control of any auxiliary loads.
3601	Compressors' on/off signal	Auxiliary contacts providing a voltagefree signal	Allows remote signalling of compressor's activation or remote control of any auxiliary loads.
4121	Forced shut down	Digital inlet to switch off the unit from remote	
4161	Remote summer winter switch	Digital inlet to switch the unit operating mode from cooling to heating and viceversa	
4162	Automatic summer/winter switch	The unit changes its operating mode from cooling to heating according to outdoor and indoor air temperature	
6171	Input remote demand limit	Digital input (voltage free) to enable demand limit function	It permits to limit the unit's power absorption for safety reasons or in temporary situation.
4381	Full fresh air	This digital input allows to work full fresh air	
4391	Total recirculation	This digital input allows to work in total recirculation	
7001	Only fan mode auxiliary input	Digital input that allows to work in ventilation only (neither the hot resources or the compressors are switched on)	
4442	Double set point return temperature	It is possible to choose a second temperature set point value, different from that normally set and choose with whom to work via a digital input	
4444	Continuous set point return temperature	Return temperature set point variation is managed through analog input; the set point varies between a minimum and	
4271	Ambient air probe	Return air temperature probe supplied loose for ambient installation	
4272	Return air probe	Return air temperature probe supplied loose for return duct installation	
2101	Rubber anti vibration device		
9966	Nylon packing	In addition to standard packing (opt. 9970), all the rooftop unit is wrapped with a nylon layer	
9970	Standard packing	The unit is supplied with plastic infills on the delivery and return of the treated air. Also lifting eye-plates are supplied as standard.	
9979	Container packing	In addition to nylon packing (opt. 9966), with container packing the unit is provided with handling devices to load it on a container (metal slides, front handling bar).	
9996	Container slides	In addition to standard packing (opt. 9970), the unit is provided with handling devices to load it on a container (metal slides, front handling bar).	

6. GENERAL TECHNICAL SPECIFICATIONS

WSM2 /AR - Standard unit						
SIZE			0052	0062	0082	0092
Cooling (Gross Value)						
Cooling capacity	(1)	kW	15,8	18,0	20,9	27,4
Sensible capacity	(1)	kW	11,8	14,2	16,9	22,0
Total power consumption	(1)	kW	4,8	5,9	7,0	10,1
EER	(1)	-	3,30	3,00	3,00	2,70
Heating (Gross Value)						
Heating capacity	(2)	kW	15,9	18,9	22,2	27,7
Total power consumption	(2)	kW	5,4	5,7	6,4	9,4
COP	(2)	-	2,90	3,30	3,50	3,00
Supply fans						
Type			Radial fan (plug fan)			
			EC motor with built-in controller			
Number		n°	1	1	1	1
Supply air flow-rate		m³/h	2.500	3.500	4.500	5.500
Available external static pressure	(3)	Pa	250	250	250	250
Outdoor fans						
Type			Axial φ 800mm			
Number		n°	1	1	1	1
External air flow-rate		m³/h	12000	15000	13000	12000
Nominal installed power		kW	1,95	1,95	1,95	1,95
Compressors						
No. compressors		n°	2	2	2	2
No. Circuits		n°	1	1	1	1
Number of capacity		n°	2	2	2	2
Refrigerant charge	(8)	kg	2	3	4	5
Refrigerant			R410A			
Sound power						
Global - Heating	(4)	dB(A)	76	76	78	80
Global - Cooling	(4)	dB(A)	76	76	78	80
Weights and dimensions						
Length		mm	2.055			
Width		mm	1.355			
Height		mm	1.640			
Standard unit operating weight	(5)	kg	520	540	570	590

Notes:

(1) Cooling: Outdoor 35°C 50% R.H. / Indoor 27°C 47% R.H. / Mix 0%.

(2) Heating: Outdoor 7°C 87% R.H. / Indoor 20°C 50% R.H. / Mix 0%.

(3) ESP for standard configuration (optional accessories not included/calculated).

(4) Sound power on the basis of measurements made in compliance with ISO 3744. For complete sound data consult Elca World

(5) Unit in standard configuration/execution, without optional accessories.

(8) The refrigerant charge is the result of a theoretical calculation and could be different from the actual amount of refrigerant which is charged in the unit and on the label

GENERAL TECHNICAL SPECIFICATIONS

WSM2 /MF						
SIZE			0052	0062	0082	0092
Cooling (Gross Value)						
Cooling capacity	(1)	kW	16,9	19,3	22,3	29,3
Sensible capacity	(1)	kW	12,0	14,4	17,2	22,2
Total power consumption	(1)	kW	4,8	6,0	7,1	10,2
EER	(1)	-	3,50	3,20	3,20	2,90
Heating (Gross Value)						
Heating capacity	(2)	kW	16,1	19,1	22,4	28,0
Total power consumption	(2)	kW	5,0	5,3	6,0	8,8
COP	(2)	-	3,20	3,60	3,70	3,20
Supply fans						
Type			Radial fan (plug fan)			
			EC motor with built-in controller			
Number		n°	1	1	1	1
Supply air flow-rate		m³/h	2.500	3.500	4.500	5.500
Available external static pressure	(3)	Pa	250	250	250	250
Outdoor fans						
Type			Axial φ 800mm			
Number		n°	1	1	1	1
External air flow-rate		m³/h	12000	15000	13000	12000
Nominal installed power		kW	1,95	1,95	1,95	1,95
Compressors						
No. compressors		n°	2	2	2	2
No. Circuits		n°	1	1	1	1
Number of capacity		n°	2	2	2	2
Refrigerant charge	(8)	kg	2	3	4	5
Refrigerant			R410A			
Sound power						
Global - Heating	(4)	dB(A)	76	76	78	80
Global - Cooling	(4)	dB(A)	76	76	78	80
Weights and dimensions						
Length	(7)	mm	2.430			
Width		mm	1.355			
Height		mm	1.640			
Standard unit operating weight	(5)	kg	550	570	600	620

Notes:

(1) Cooling: Outdoor 35°C 50% R.H. / Indoor 27°C 47% R.H. / Mix 0%.

(2) Heating: Outdoor 7°C 87% R.H. / Indoor 20°C 50% R.H. / Mix 0%.

(3) ESP for standard configuration (optional accessories not included/calculated).

(4) Sound power on the basis of measurements made in compliance with ISO 3744. For complete sound data consult Elca World

(5) Unit in standard configuration/execution, without optional accessories.

(8) The refrigerant charge is the result of a theoretical calculation and could be different from the actual amount of refrigerant which is charged in the unit and on the label

GENERAL TECHNICAL SPECIFICATIONS

WSM2 /AX-F						
SIZE			0052	0062	0082	0092
Cooling (Gross Value)						
Cooling capacity	(1)	kW	17,2	19,6	22,7	29,9
Sensible capacity	(1)	kW	12	14,4	17,3	22,3
Total power consumption	(1)	kW	4,92	6,17	7,26	10,4
EER	(1)	-	3,5	3,2	3,1	2,9
Heating (Gross Value)						
Heating capacity	(2)	kW	16,3	19,5	22,9	28,7
Total power consumption	(2)	kW	5,13	5,45	6,3	9,14
COP	(2)	-	3,2	3,6	3,6	3,1
Supply fans						
Type			Radial fan (plug fan)			
			EC motor with built-in controller			
Number		n°	1	1	1	1
Supply air flow-rate		m³/h	2.500	3.500	4.500	5.500
Available external static pressure	(3)	Pa	250	250	250	250
Outdoor fans						
Type			Axial ø 800mm			
Number		n°	1	1	1	1
External air flow-rate		m³/h	12000	15000	13000	12000
Nominal installed power		kW	1,95	1,95	1,95	1,95
Compressors						
No. compressors		n°	2	2	2	2
No. Circuits		n°	1	1	1	1
Number of capacity		n°	2	2	2	2
Refrigerant charge	(8)	kg	2	3	4	5
Refrigerant			R410A			
Return fans						
Type			Radial fan (plug fan)			
			EC motor with built-in controller			
Number		n°	1	1	1	1
Return air flow rate		m³/h	875	1.225	1.575	1.925
Available external static pressure	(3)	Pa	370	370	370	370
Sound power						
Global - Heating	(4)	dB(A)	81	82	82	84
Global - Cooling	(4)	dB(A)	81	82	82	84
Weights and dimensions						
Length		mm	2.000			
Width	(7)	mm	1.755			
Height		mm	1.595			
Standard unit operating weight	(5)	kg	570	590	610	630

Notes:

- (1) Cooling: Outdoor 35°C 50% R.H. / Indoor 27°C 47% R.H. / Mix 35%.
- (2) Heating: Outdoor 7°C 87% R.H. / Indoor 20°C 50% R.H. / Mix 35%.
- (3) ESP for standard configuration (optional accessories not included/calculated).
- (4) Sound power on the basis of measurements made in compliance with ISO 3744. For complete sound data consult Elca World.
- (5) Unit in standard configuration/execution, without optional accessories.
- (7) The dimension does not include hoods and the thickness of the pre-filter for fresh air if present.
- (8) The refrigerant charge is the result of a theoretical calculation and could be different from the actual amount of refrigerant which is charged in the unit and on the label

TECHNICAL DATA SEASONAL EFFICIENCY IN HEATING (EN14825:2016 VALUE)

SIZE			0052	0062	0082	0092
WEATHER CONDITIONS - AVERAGE (1)						
Definition	Symbol					
Air flow		m ³ /h	2.500	3.500	4.500	5.500
Design heating load	P _{design,h}	kW	12,9	15,4	17,8	22,6
Reference design temperature	T _{design,h}	°C	-10,0	-10,0	-10,0	-10,0
Bivalent temperature	T _{biv}	°C	-5,5	-5,5	-5,5	-5,5
Seasonal coefficient of performance	SCOP		3,21	3,23	3,28	3,27
Seasonal space heating energy efficiency	η _{s,h}	%	125,4	126,2	128,2	127,8

(1) Indoor conditions: 20°C d.b. - 15°C w.b.
Type of calculation with fixed flow

TECHNICAL DATA SEASONAL EFFICIENCY IN COOLING (EN14825:2016 VALUE)

SIZE			0052	0062	0082	0092
WEATHER CONDITIONS - AVERAGE (2)						
Definition	Symbol					
Air flow		m ³ /h	2.500	3.500	4.500	5.500
Design cooling load	P _{design,c}	kW	15,8	18,1	21,0	27,6
Reference design temperature	T _{design,c}	°C	35,0	35,0	35,0	35,0
Seasonal coefficient of performance	SEER		3,6	3,53	3,61	3,54
Seasonal space cooling energy efficiency	η _{s,c}	%	141	138,2	141,4	138,6

(2) Indoor conditions: 27°C d.b. - 19°C w.b.
Type of calculation with fixed flow

GLOBAL SEASONAL EFFICIENCY (EN14825:2016 VALUE)

SIZE		0052	0062	0082	0092
ErP Tier Achieved (Cooling & Heating)	ErP Tier	2021	2021	2021	2021

EUROVENT CERTIFICATION PROGRAM

MEHITS S.p.A., in order to ensure greater transparency in relation to its rooftop units, has chosen have the performance of its units certified by a third party, Eurovent Certita Certification, a body recognised both in Europe and internationally (www.eurovent-certification.com).

The performance values certified in the third-party laboratory are declared in accordance with the following regulations:

EN 14511 "Air conditioners, liquid chilling packages and heat pumps with electrically driven compressors for space heating and cooling".

EN 14825 "Air conditioners, liquid chilling packages and heat pumps, with electrically driven compressors, for space heating and cooling. Testing and rating at part-load conditions and calculation of seasonal performance"

EN 12102 "Air conditioners, liquid chilling packages, heat pumps and dehumidifiers with electrically driven compressors for space heating and cooling - Measurement of airborne noise – Determination of the sound power level".

The main certified values are shown below.

WSM2					
SIZE		0052	0062	0082	0092
Nominal airflow rate (indoor)	m ³ /h	2.500	3.500	4.500	5.500
External Static Pressure	Pa	100	100	124	124
Cooling capacity (EN14511)	kW	15,81	18,10	21,00	27,50
EER (EN 14511)		3,44	3,19	3,16	2,83
Energy Efficiency Ratio Class for air cooled units		A	A	A	B
Seasonal Energy Efficiency (cooling) according to EN14825, η _{s,c}		141,00	138,20	141,40	138,60
Heating capacity (EN14511)	kW	15,90	18,90	22,10	27,60
COP (EN 14511)		3,03	3,51	3,65	3,07
Coefficient of Performance Class for air cooled units		C	A	A	C
Seasonal Energy Efficiency (heating) according to EN14825, η _{s,h}		125,40	126,20	128,20	127,80
Sound power level (LWO - environment)	dB(A)	76	79	78	80
Sound power level (LWI - duct)	dB(A)	76	85	80	84

COMBINATION ACCESSORIES

ACCESSORIES CONFIGURATION				SUPPLY (*)						RETURN (*)						
Function	Accessories		Possible?	DIRECTION	TOP	RIGHT	LEFT	FRONT	REAR	BOTTOM	TOP	RIGHT	LEFT	FRONT	REAR	BOTTOM
	Cod.	Description		LIST PRICE CODE	2075	2076	2077	2079	2073	2072	2067	2062	2065	2066	2061	2063
AR	1467	HOT WATER COIL 2 ROWS	ONLY ONE	OK	NO	NO	OK	OK	OK	NO	NO	OK	NO	NO	NO	NO
	1468	HOT WATER COIL 3 ROWS														
	1466 + EL. HEATER POWER CODE	ELECTRIC HEATER														
	1461	HOT GAS COIL	ONLY ONE													
	2526	HIGH EFF. AIR FILTER ePM01 50% (F7)														
	2528	HIGH EFF. AIR FILTER ePM01 80% (F9)														
MF	1467	HOT WATER COIL 2 ROWS	ONLY ONE	OK	NO	NO	OK	OK	OK	OK	NO	NO	OK	OK	NO	NO
	1468	HOT WATER COIL 3 ROWS														
	1466 + EL. HEATER POWER CODE	ELECTRIC HEATER														
	1461	HOT GAS COIL	ONLY ONE													
	2526	HIGH EFF. AIR FILTER ePM01 50% (F7)														
	2528	HIGH EFF. AIR FILTER ePM01 80% (F9)														
AX-F	1467	HOT WATER COIL 2 ROWS	ONLY ONE	OK	OK	NO	OK	NO	NO	OK	OK	NO	NO	OK	NO	NO
	1468	HOT WATER COIL 3 ROWS														
	1466 + EL. HEATER POWER CODE	ELECTRIC HEATER														
	1461	HOT GAS COIL	ONLY ONE													
	2526	HIGH EFF. AIR FILTER ePM01 50% (F7)														
	2528	HIGH EFF. AIR FILTER ePM01 80% (F9)														

(*): Air flow directions point of view is in front of the electric board

SUPPLY FANS (For all functions)

Size		0052	0062	0082	0092
Minimum air flow	[m ³ /h]	2.000	2.800	3.600	4.400
Nominal air flow	[m ³ /h]	2.500	3.500	4.500	5.500
Maximum air flow	[m ³ /h]	3.000	4.200	5.200	6.270

Option code	Type	SIZE	0052	0062	0082	0092
4250	EC PLUG FAN, standard	F.L.I.	1,2	1,2	1,5	1,5
		F.L.A.	9,0	9,0	9,0	9,0
	Number	Nr.	1	1	1	1
4251	EC PLUG FAN, higher rating (MM1)	F.L.I.	1,5	1,5	2,5	2,5
		F.L.A.	9,0	9,0	18,0	18,0
	Number	Nr.	1	1	1	1

The electrical data shown are total values.

FLI Power consumption in max. admissible conditions. [kW]

FLA Current draw in max. admissible conditions. [A]

Unit in the standard configuration, without accessories

Limit flow-rate to ensure a maximum coil flow-through speed of 2.7 m/s

For detailed specifications contact Elca World

EXTRACTION FANS (For AX-F functions)

Type	SIZE	0052	0062	0082	0092
EC PLUG FAN	F.L.I.	2,0			
	F.L.A.	3,3			
Nominal diameter fan	mm	250			
Number	Nr.	1			

The electrical data shown are total values.

FLI Power consumption in max. admissible conditions. [kW]

FLA Current draw in max. admissible conditions. [A]

Unit in the standard configuration, without accessories

For detailed specifications contact Elca World

ELECTRICAL DATA

AR and MF functions														
Size	Compressors			Supply fans			Axial fans			Auxiliary		Total		
	No.	F.L.I.	F.L.A.	No.	F.L.I.	F.L.A.	No.	F.L.I.	F.L.A.	F.L.I.	F.L.A.	F.L.I.	F.L.A.	S.A.
		[kW]	[A]		[kW]	[A]		[kW]	[A]					
0052	2	7	11	1	1,15	1,90	1	1,95	3,30	0,50	0,72	10	17	49
0062	2	7	13	1	1,15	1,90	1	1,95	3,30	0,50	0,72	11	19	58
0082	2	9	14	1	1,50	2,40	1	1,95	3,30	0,50	0,72	13	20	57
0092	2	11	17	1	1,50	2,40	1	1,95	3,30	0,50	0,72	15	23	67

FUNZIONI AX-F																	
Size	Compressors			Supply fans			Return fans			Axial fans			Auxiliary		Total		
	No.	F.L.I.	F.L.A.	No.	F.L.I.	F.L.A.	No.	F.L.I.	F.L.A.	No.	F.L.I.	F.L.A.	F.L.I.	F.L.A.	F.L.I.	F.L.A.	S.A.
		[kW]	[A]		[kW]	[A]		[kW]	[A]		[kW]	[A]					
0052	2	7	11	1	1,15	1,90	1	1,95	3,30	1	1,95	3,30	0,50	0,72	11	21	53
0062	2	7	13	1	1,15	1,90	1	1,95	3,30	1	1,95	3,30	0,50	0,72	12	22	61
0082	2	9	14	1	1,50	2,40	1	1,95	3,30	1	1,95	3,30	0,50	0,72	13	25	60
0092	2	11	17	1	1,50	2,40	1	1,95	3,30	1	1,95	3,30	0,50	0,72	16	30	71

NOTE: Data refer to standard unit

F.L.I. Absorbed power at max. permissible conditions
 F.L.A. Absorbed current at max. permissible conditions
 L.R.A. Compressor lock rotor current
 S.A. Peak current of unit with standard motors

Electrical power input:

- 400/3/50 WITHOUT NEUTRAL
- Permissible voltage variation 10%
- Maximum unbalance between phase voltages 3%

STANDARD COMPRESSORS

Size	Type	CIRCUIT 1				
		No.	Connection	F.L.I.	F.L.A.	L.R.A.
				[kW]	[A]	[A]
0052	scroll	2	tandem	3,3	5,3	38
0062	scroll	2	tandem	3,7	6,5	46
0082	scroll	2	tandem	4,3	7,2	43
0092	scroll	2	tandem	5,5	8,6	51,5

Electrical data refer to the individual component.

FLI Power consumption in max. admissible conditions.

FLA Current draw in max. admissible conditions.

LRA Locked rotor current

HEATING WATER COIL (Accessory)

Heating water coil performances (water 80 - 60 °C)

		SIZE	0052	0062	0082	0092
2-ROWS COIL	Airflow	[m ³ /h]	2500	3500	4500	5500
	Rated thermal power	[kW]	26,1	24,1	28,0	34,5
	Rated flowrate	[m ³ /h]	1,15	1,0	1,2	1,5
	Rated pressure drops water side	[kPa]	5	9	11	11
	Pressure drop air side	[It]	3,4	3,4	3,4	4,3
3-ROWS COIL	Rated thermal power	[kW]	30,3	32,5	38,1	48,1
	Rated flowrate	[m ³ /h]	1,3	1,44	1,69	2,12
	Rated pressure drops water side	[kPa]	9	7	10	9
	Pressure drop air side	[It]	5	5	5	6,4

Nominal heating capacity, entering air temperature 20°C, to the capacity indicated and IN/OUT water temperature 80/60°C

THREE-WAY WATER VALVES (accessory)

		SIZE	0052	0062	0082	0092
2-ROWS COIL	k _{vs} valve	[m ³ /h]	4			6,3
	DN - Nominal diameter	[mm]	15			20
3-ROWS COIL	k _{vs} valve	[kPa]	6,3			10
	DN - Nominal diameter	[It]	20			25
Type of actuator			0-10 V proportional control (managed by AIR 3000 TE controller)			
Type of valve connection			Threaded connections			

ELECTRICAL HEATING COIL (Accessory)

Combinations units / electrical heating coil

ELECTRICAL HEATING COIL	Thermal power	Absorbed current	UNIT SIZE			
			0052	0062	0082	0092
	[kW]	[A]				
6	6	9	X	X	X	X
9	9	13	X	X	X	X
12	12	17	X	X	X	X
18	18	26			X	X

Three-phase power supply with star connection, no neutral

7. OPERATING LIMITS

NOTE: OPERATING LIMITS CALCULATED IN THE FOLLOWING CONDITIONS:

- Max air flow
- Unit correctly installed and used
- Operating in stable conditions

- External air temperature limit
- - - Treatment coil entering air temperature limit

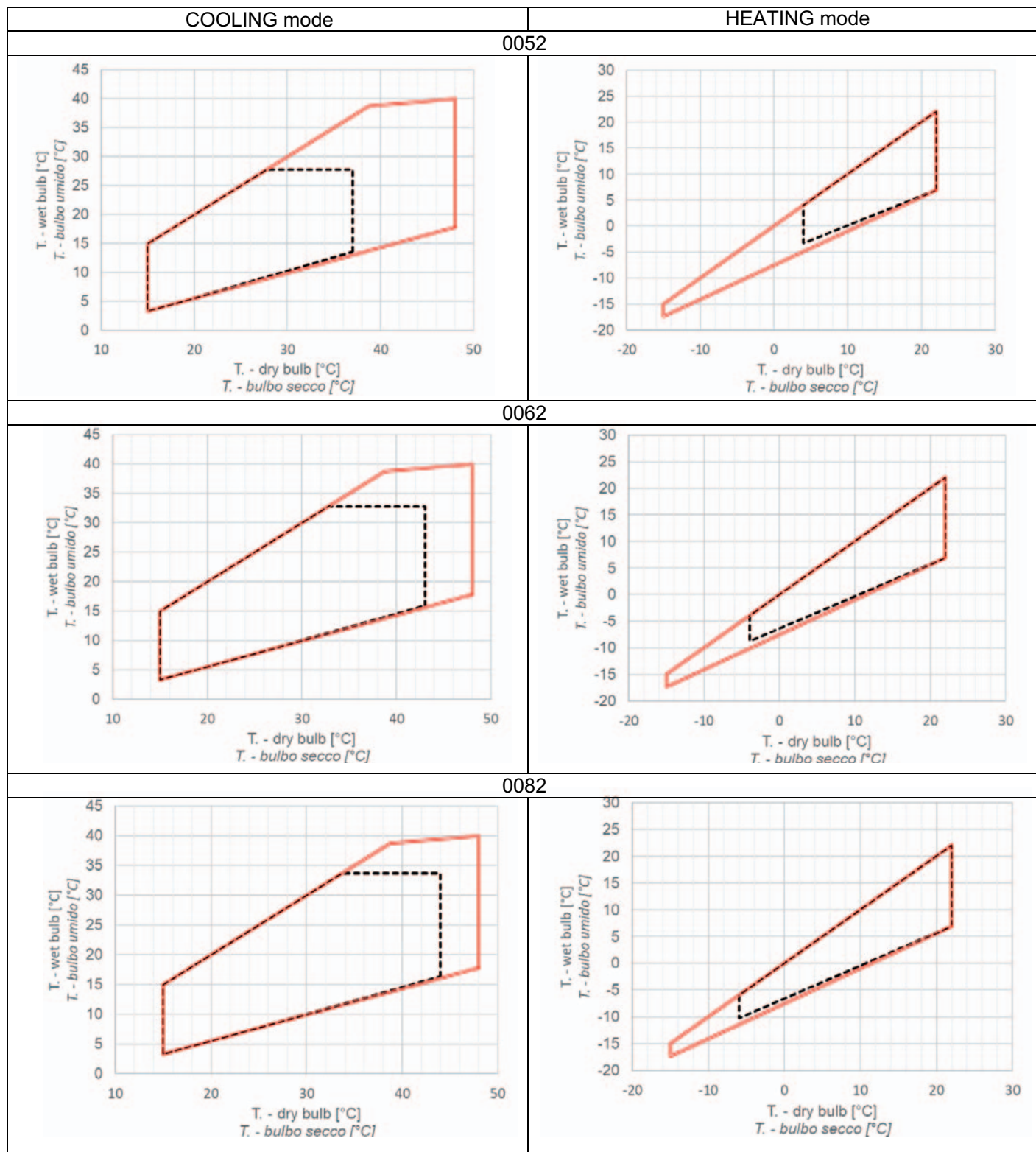

NOTE: OPERATING LIMITS CALCULATED IN THE FOLLOWING CONDITIONS:

- Max air flow
- Unit correctly installed and used
- Operating in stable conditions

— External air temperature limit
 - - - Treatment coil entering air temperature limit

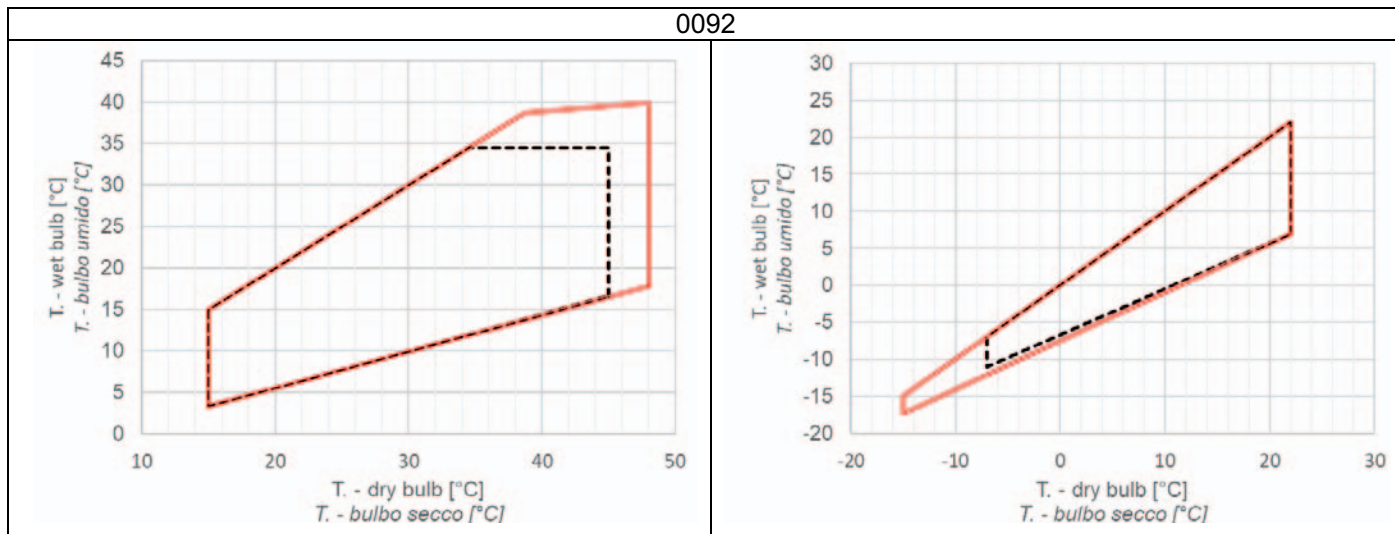

8. DIMENSIONAL DRAWINGS

The reference of the supply and return air flow directions is from the front of the electrical panel.

Remarks: for installation purposes, please refer to the documentation sent after the purchase-contract. This technical data should be considered as indicative. Mitsubishi Electric Hydronics & IT Cooling Systems S.p.A. may modify them at any moment. Data valid for standard units without any additional option.

Legend symbols		
SUPPLY AIR DIRECTION		
CODE (price list)	DESCRIPTION	CODE (draw)
2072	BOTTOM SIDE SUPPLY AIR	M1
2075	TOP SIDE SUPPLY AIR	M2
2076	RIGHT SIDE SUPPLY AIR	M3
2077	LEFT SIDE RETURN AIR	M4
2073	REAR SIDE SUPPLY AIR	M5
2079	FRONT SIDE SUPPLY AIR	M6

Legend symbols		
RETURN AIR DIRECTION		
CODE (price list)	DESCRIPTION	CODE (draw)
2061	REAR SIDE RETURN AIR	R1
2062	RIGHT SIDE RETURN AIR	R2
2063	BOTTOM SIDE RETURN AIR	R3
2065	LEFT SIDE RETURN AIR	R4
2067	TOP SIDE RETURN AIR	R5
2066	FRONT SIDE RETURN AIR	R6

WSM2 /AR

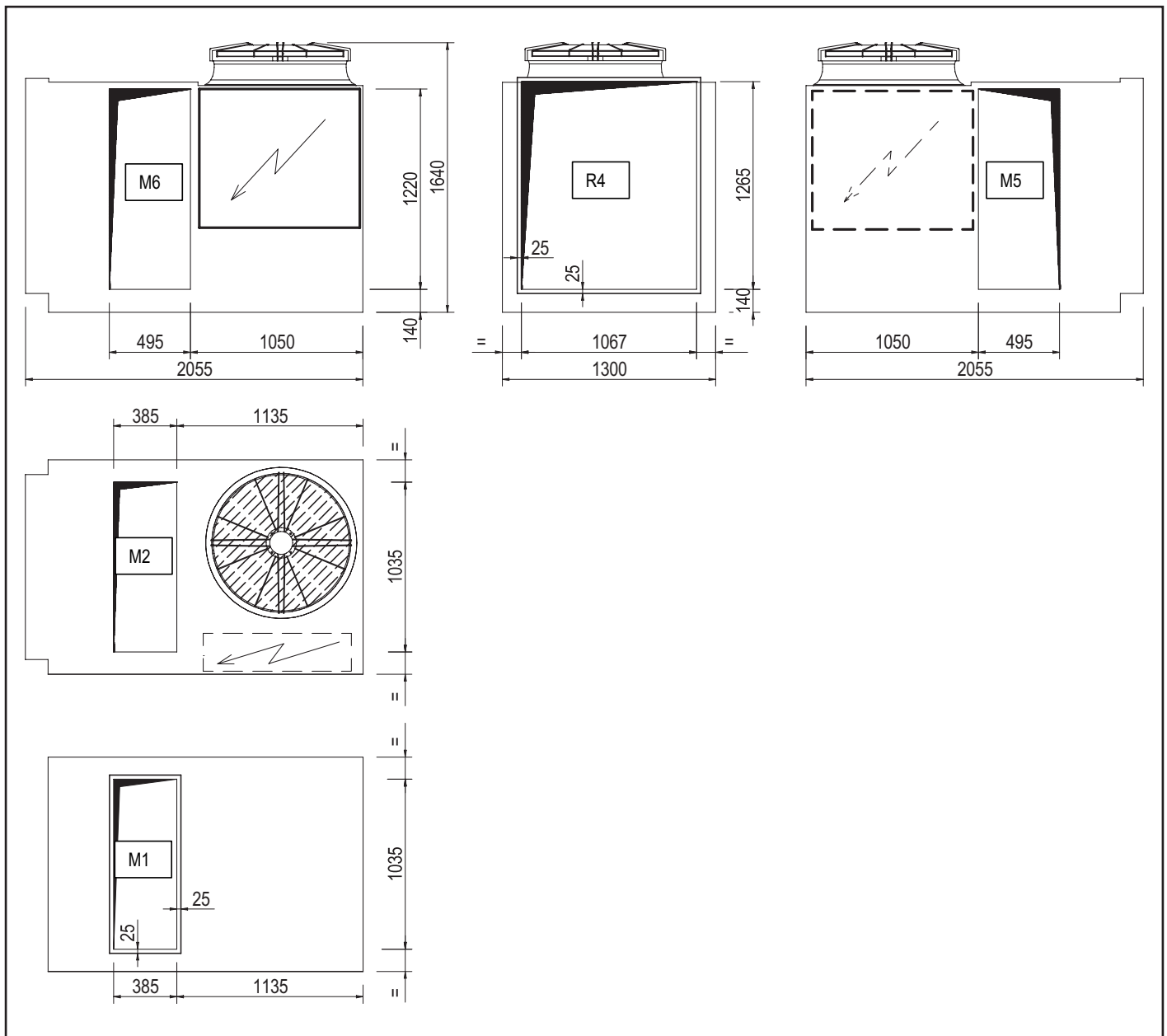

The reference of the supply and return air flow directions is from the front of the electrical panel.

Remarks: for installation purposes, please refer to the documentation sent after the purchase-contract. This technical data should be considered as indicative. Mitsubishi Electric Hydronics & IT Cooling Systems S.p.A. may modify them at any moment. Data valid for standard units without any additional option.

Legend symbols		
SUPPLY AIR DIRECTION		
CODE (price list)	DESCRIPTION	CODE (draw)
2072	BOTTOM SIDE SUPPLY AIR	M1
2075	TOP SIDE SUPPLY AIR	M2
2076	RIGHT SIDE SUPPLY AIR	M3
2077	LEFT SIDE RETURN AIR	M4
2073	REAR SIDE SUPPLY AIR	M5
2079	FRONT SIDE SUPPLY AIR	M6

Legend symbols		
RETURN AIR DIRECTION		
CODE (price list)	DESCRIPTION	CODE (draw)
2061	REAR SIDE RETURN AIR	R1
2062	RIGHT SIDE RETURN AIR	R2
2063	BOTTOM SIDE RETURN AIR	R3
2065	LEFT SIDE RETURN AIR	R4
2067	TOP SIDE RETURN AIR	R5
2066	FRONT SIDE RETURN AIR	R6

WSM2 /MF

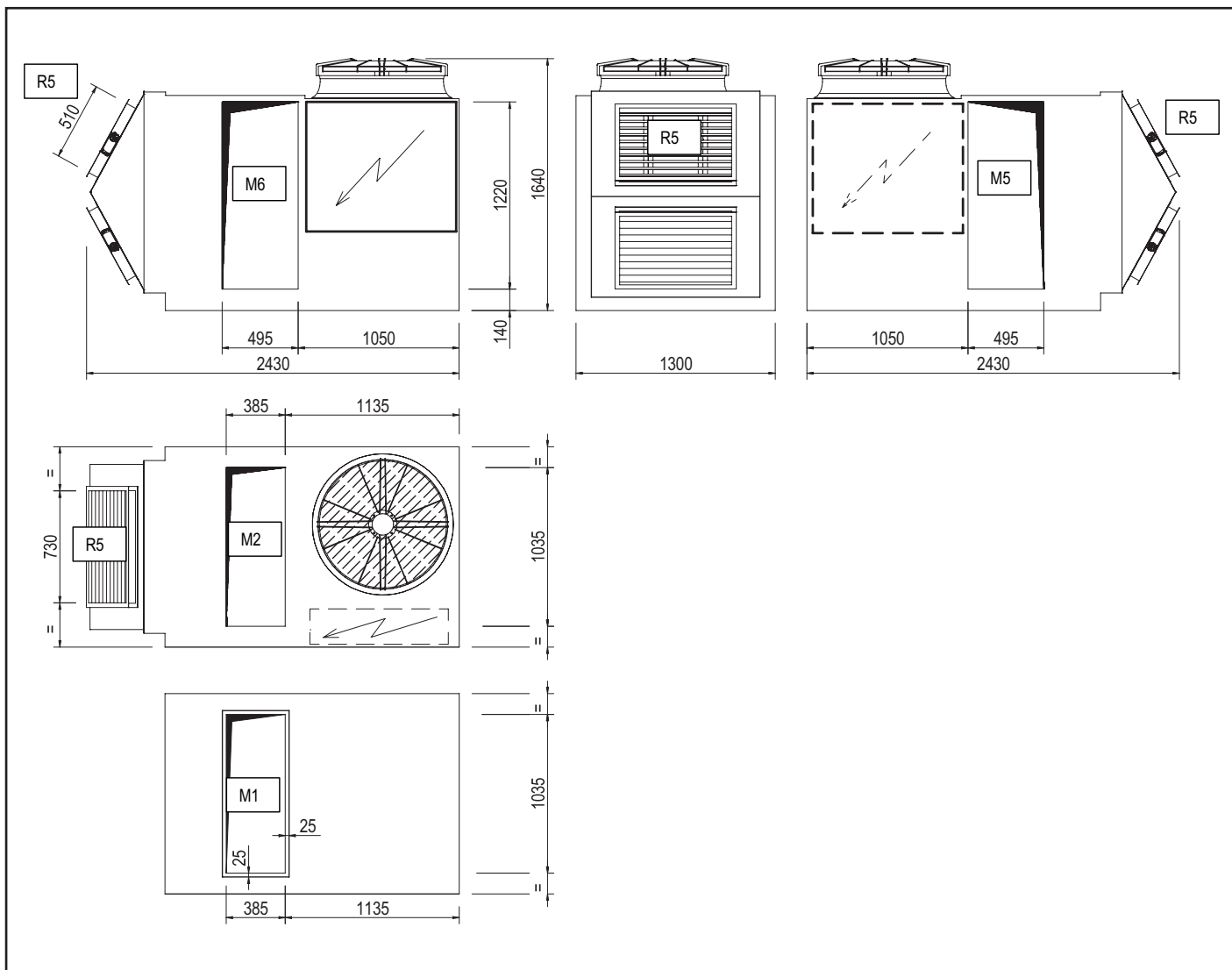

The reference of the supply and return air flow directions is from the front of the electrical panel.

Remarks: for installation purposes, please refer to the documentation sent after the purchase-contract. This technical data should be considered as indicative. Mitsubishi Electric Hydronics & IT Cooling Systems S.p.A. may modify them at any moment. Data valid for standard units without any additional option.

Legend symbols		
SUPPLY AIR DIRECTION		
CODE (price list)	DESCRIPTION	CODE (draw)
2072	BOTTOM SIDE SUPPLY AIR	M1
2075	TOP SIDE SUPPLY AIR	M2
2076	RIGHT SIDE SUPPLY AIR	M3
2077	LEFT SIDE RETURN AIR	M4
2073	REAR SIDE SUPPLY AIR	M5
2079	FRONT SIDE SUPPLY AIR	M6

Legend symbols		
RETURN AIR DIRECTION		
CODE (price list)	DESCRIPTION	CODE (draw)
2061	REAR SIDE RETURN AIR	R1
2062	RIGHT SIDE RETURN AIR	R2
2063	BOTTOM SIDE RETURN AIR	R3
2065	LEFT SIDE RETURN AIR	R4
2067	TOP SIDE RETURN AIR	R5
2066	FRONT SIDE RETURN AIR	R6

WSM2 /MF

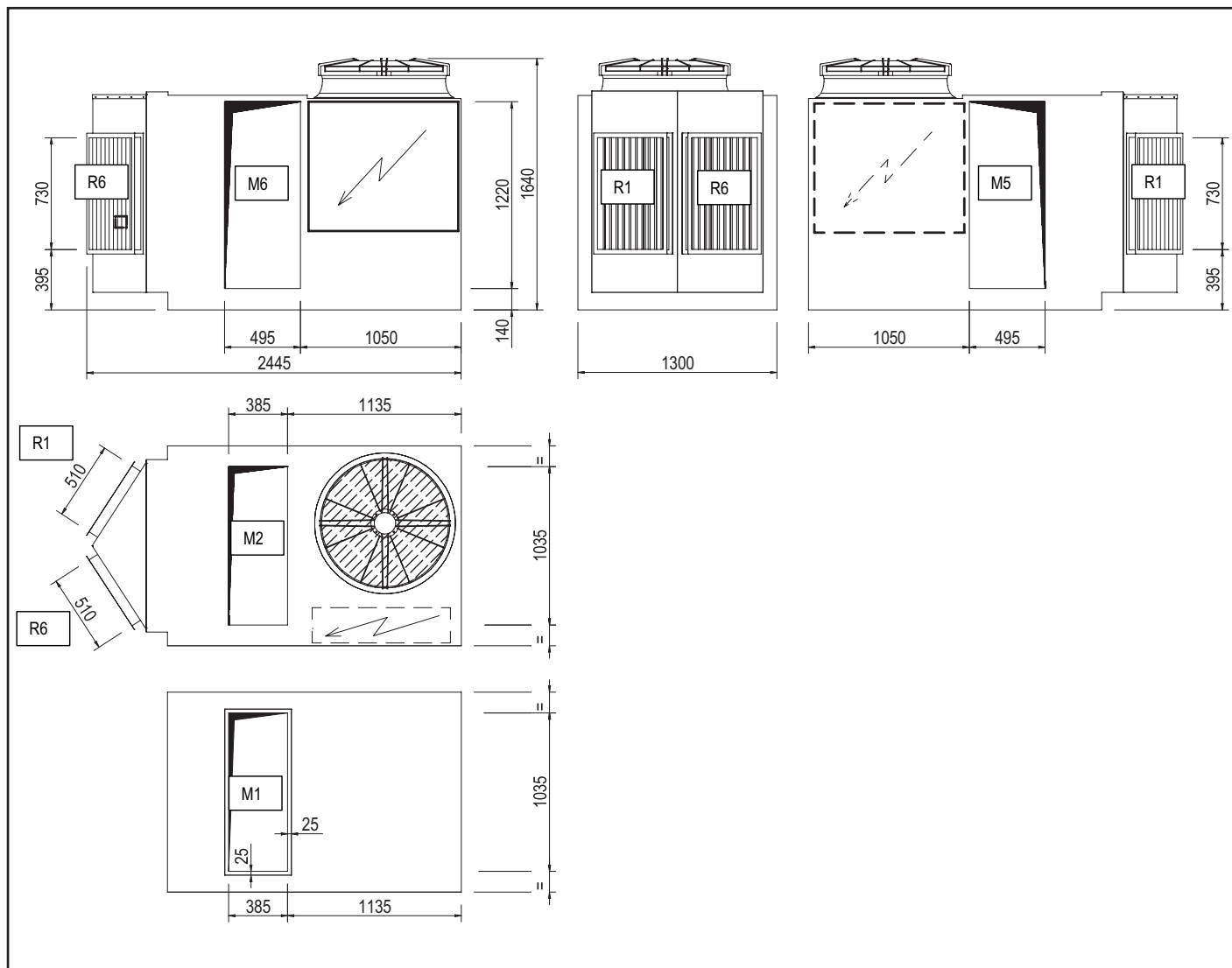

The reference of the supply and return air flow directions is from the front of the electrical panel.

Remarks: for installation purposes, please refer to the documentation sent after the purchase-contract. This technical data should be considered as indicative. Mitsubishi Electric Hydronics & IT Cooling Systems S.p.A. may modify them at any moment. Data valid for standard units without any additional option.

Legend symbols		
SUPPLY AIR DIRECTION		
CODE (price list)	DESCRIPTION	CODE (draw)
2072	BOTTOM SIDE SUPPLY AIR	M1
2075	TOP SIDE SUPPLY AIR	M2
2076	RIGHT SIDE SUPPLY AIR	M3
2077	LEFT SIDE RETURN AIR	M4
2073	REAR SIDE SUPPLY AIR	M5
2079	FRONT SIDE SUPPLY AIR	M6

Legend symbols		
RETURN AIR DIRECTION		
CODE (price list)	DESCRIPTION	CODE (draw)
2061	REAR SIDE RETURN AIR	R1
2062	RIGHT SIDE RETURN AIR	R2
2063	BOTTOM SIDE RETURN AIR	R3
2065	LEFT SIDE RETURN AIR	R4
2067	TOP SIDE RETURN AIR	R5
2066	FRONT SIDE RETURN AIR	R6

WSM2 /AX-F

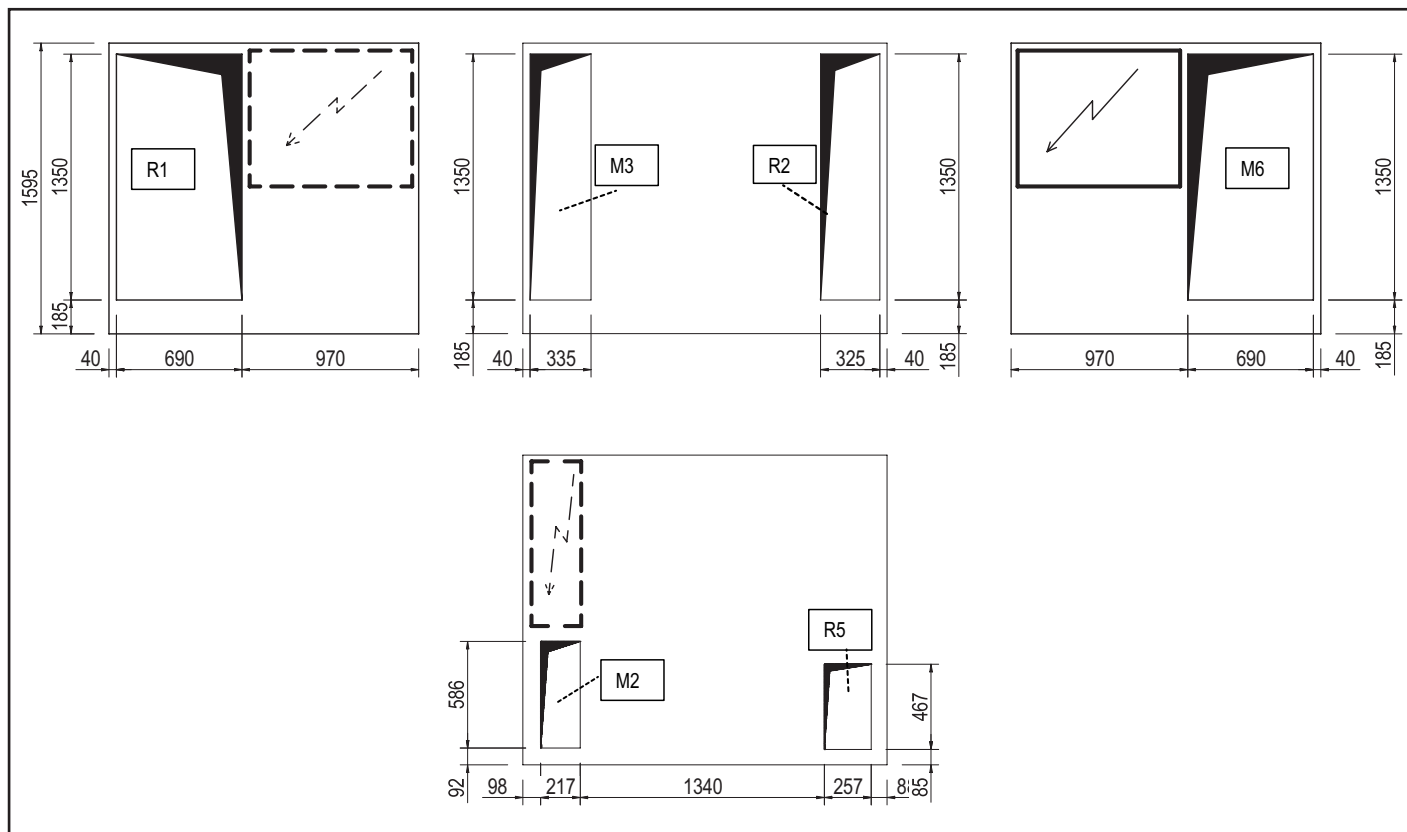



for a greener tomorrow

Eco Changes is the Mitsubishi Electric Group's environmental statement, and expresses the Group's stance on environmental management. Through a wide range of businesses, we are helping contribute to the realization of a sustainable society.



MITSUBISHI ELECTRIC HYDRONICS & IT COOLING SYSTEMS S.p.A.

Head Office: M11 - Via Caduti di Cefalonia 1 - 36061 Bassano del Grappa (VI) - Italy

Tel (+39) 0424 509 500 - Fax (+39) 0424 509 509

www.climaveneta.com

www.melcohit.com