



i-BX 004 - 035

NEW!

4,30-35,1 kW

Chiller, air source for outdoor installation



R HFC R410A

SCROLL

ROTATIVE

AXIAL

P PLATES

**EUROVENT
CERTIFIED
PERFORMANCE**
www.eurovent-certification.com

INV.COMP.

EEV

(The photo of the unit is indicative and may vary depending on the model)

- ErP READY
- SYSTEM EFFICIENCY
- HIGH EFFICIENCY AT PARTIAL LOAD
- HIGH EFFICIENCY COMPONENTS
- EXTENSIVE OPERATING LIMITS
- INTEGRATED HYDRONIC MODULE

CERTIFICATIONS

Product certifications



Voluntary product certifications



Check ongoing validity of certificate:

www.eurovent-certification.com

or

www.certiflash.com

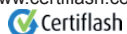

System certifications



MITSUBISHI ELECTRIC HYDRONICS & IT COOLING SYSTEMS S.p.A.

Quality System complying with the requirements of UNI EN ISO 9001:2008 regulation
Environmental Management System complying with the requirements of UNI EN ISO 14001:2004 regulation
Occupational Health and Safety Management System complying with the requirements of BS OHSAS 18001:2007

INDEX

1. PRODUCT PRESENTATION	5
2. UNIT STANDARD CONFIGURATION	7
3. ELECTRONIC CONTROLLER	8
4. OPERATING CHARACTERISTICS	9
5. ACCESSORIES	11
6. GENERAL TECHNICAL DATA	16
7. ENERGY EFFICIENCY	18
8. OPERATING LIMITS	18
9. ETHYLENE GLYCOL MIXTURE	19
10. FOULING FACTORS	19
11. HYDRAULIC DATA	19
12. MINIMUM AND MAXIMUM SYSTEM WATER CONTENT	21
13. SYSTEM PUMP CURVES	22
14. HYDRONIC GROUP	24
15. UTILITY WATER CIRCUIT CONNECTION DIAGRAM	25
16. ELECTRICAL DATA	26
17. FULL LOAD SOUND LEVEL	27
18. POSITION OF THE WATER CONNECTIONS	28
19. DIMENSIONAL DRAWINGS	29

Liability disclaimer

The present publication is drawn up by of information only and does not constitute an offer binding upon Mitsubishi Electric Hydronics & IT Cooling Systems S.p.A.

Mitsubishi Electric Hydronics & IT Cooling Systems S.p.A. has compiled the content of this publication to the best of its knowledge. The data contained herein are subject to change without notice. Mitsubishi Electric Hydronics & IT Cooling Systems S.p.A. explicitly rejects any liability for any direct or indirect damage, in the broadest sense, arising from or related to the use and/or interpretation of this publication.

All content is copyrighted by Mitsubishi Electric Hydronics & IT Cooling Systems S.p.A.

The units highlighted in this publication contain HFC R410A [GWP₁₀₀ 2088] fluorinated greenhouse gases.

LEGEND**Functions****Refrigerant****Compressors****Fan****Exchangers****Other features**

1. PRODUCT PRESENTATION

1.1 GREEN CERTIFICATION RELEVANT

Mitsubishi Electric Hydronics & IT Cooling Systems S.p.A., as a major player in the world HVAC market and a leading manufacturer of energy efficient, sustainable HVAC solutions, recognizes and supports the diffusion of green certification systems, as an effective way to deliver high performance buildings and improve the quality and the sustainability of the built environment.

Since the first certification system was introduced at the beginning of the 1990s, the demand for certified buildings has grown considerably, as well as the number of standards, rating and certification programs.

Operating worldwide Mitsubishi Electric Hydronics & IT Cooling Systems S.p.A., has extensive experience with many of them and is active member of Green Building Council Italy.

Mitsubishi Electric Hydronics & IT Cooling Systems S.p.A., commitment to develop responsible and sustainable HVAC solutions, is reflected by a full range of premium efficiency products and systems, designed with special care to improve building energy performance ratings, according to major certification protocols, including LEED, BREAM, GREENSTAR, BCA, NABERS, DNGB, HQE and BEAM.

To find out more about how our products contribute to enhanced green certification rating and energy performance of a building, please refer to:

<https://www.melcohit.com/GLOBAL/Company/Green-Certifications/QR%20code/>



1. PRODUCT PRESENTATION

1.2 NOMENCLATURE

1	2	3	4	5	6	7	8	9
i	- B X -	N	-	0 0 4	M	H	A	N R V

Code	Descriptions	Extensions
1	Model	i-BX Chiller
		i-BX-N Heat pump
2	Segment	- Comfort
		Y Process
3	Nominal capacity [kW]	004-006-008-010-013-015-020-025-030-035
4	Power supply	M 230/1/50
		T 400/3/50
5	Hydronic Module	N Without hydronic module
		H With hydronic module
6	Tube & Fin coil	A Cu/Al regular coil
		B Cu/Cu tube & fin coil
		E Epoxy pre-painted fins
7*	Basement electric heater	N Without basement electric heater
		S With basement electric heater
8	Coil protection grill	N Without protection grill
		R With protection grill
9	Structure & Panelling	V All parts polyester-powder painted

*Not available for i-BX

Outdoor unit for cold water production, with hermetic rotary compressors with variable speed (Inverter Driven) in a single-circuit configuration using R410A refrigerant, air side heat exchanger with copper tubes and aluminum fins, water side steel brazed plate heat exchanger. The unit is equipped with electronic expansion valve and integrated hydraulic module as standard.

Flexible and reliable unit that adapts to the actual load conditions thanks to the accurate temperature control combined with the use of inverter technology. The high performance at both full and partial load, is achieved due to the accurate design of the unit and the use of variable speed motor (inverter).

The chillers i-BX are used in many applications, even completely different from each other, suitable for comfort and industrial processes, without making any compromises.

1.3 ErP READY

The high level of efficiency of i-BX at partial load meets and exceeds the minimum seasonal efficiency for cooling, SEER, according with the eco-sustainable design requirements for all products using energy.

For this reason, the unit represents the best choice for all the hydronic application on the residential and commercial markets. The unit is suitable also for industrial market, satisfying the seasonal energy performance ratio SEPR.

1.4 SYSTEM EFFICIENCY

The unit is designed with a system approach: all components are set in synergy according to a proprietary logic to obtain the highest efficiency.

1.5 HIGH EFFICIENCY AT PARTIAL LOAD

High seasonal efficiency in both heating and cooling mode, using DC inverter technology to modulate compressor operation and deliver the exact amount of energy based on the actual needs of the building. High efficiency for low energy consumption during the operating hours.

1.6 HIGH EFFICIENCY COMPONENTS

In terms of improving performance and reducing power consumption, the electronic thermostatic valve is a key component that maximises system efficiency, as well as the hydronic kit with inverter water pump and the modulating the fans speed as standard equipments.

1.7 EXTENSIVE OPERATING LIMITS

Full load operation is ensured with outdoor air temperature up to 45°C during summer and down to -10°C of outdoor air temperature during winter. Production of evaporator leaving water temperature from -8°C to 18°C.

1.8 INTEGRATED HYDRONIC MODULE

The integrated hydronic include all the water circuit components (anti-freeze electrical heater on plate heat exchanger, air release valve, flow switch, water filter, safety valve, EC water pump

2. UNIT STANDARD CONFIGURATION

2.1 Air cooled chiller, air source for outdoor installation

Outdoor unit for cold water production, with hermetic rotary compressors with variable speed (Inverter Driven) in a single-circuit configuration using R410A refrigerant, air side heat exchanger with copper tubes and aluminum fins, water side steel brazed plate heat exchanger. The unit is equipped with electronic expansion valve and integrated hydraulic module as standard.

A flexible and reliable unit that adapts to the actual load conditions thanks to the accurate temperature control combined with the use of inverter technology. The precise design and the use of innovative variable speed motors (inverters) ensures a high level of energy efficiency both at full and partial loads.

The chillers i-BX are used in many applications, even completely different from each other, suitable for comfort and industrial processes, without making any compromises.

2.2 Structure

Structure in hot-galvanised shaped sheet steel with a suitable thickness. All parts polyester-powder painted RAL 7035. The self-supporting frame is built to guarantee maximum accessibility for servicing and maintenance operations.

2.3 Panelling

The external paneling made from hot galvanised metal plate and painted with epoxy powder coat RAL 7035. The panels are easy to remove for quick and easy access to the inside components from either side of the unit.

2.4 Variable-speed compressor

The inverter scroll compressor uses a brushless Interior Permanent Magnet (IPM) design to give you higher efficiency across a wider range of applications and with an oil sump heater. Inverter logic ensures a soft start that reduces inrush current. The frequency converter is designed with built-in harmonic filters, making it easy to install in the electrical panel while complying with industry standards.

2.5 Utility-side heat exchanger

Braze welded AISI 316 steel plate heat exchanger. The heat exchangers are lined on the outside with a layer of closed-cell neoprene to prevent condensation.

When the unit is operating, the heat exchangers are protected against no flow conditions by a flow switch. The unit is also ready to operate using non-freezing fluid mixes, down to heat exchanger outlet temperatures of -8° and with a frost protection heater on the heat exchanger.

2.6 Source-side heat exchanger

Finned coil heat exchanger made of copper tubes and aluminium fins, spaced apart so as to guarantee maximum heat exchange efficiency. The unit is fitted as standard with protection grills on the coil.

2.7 Fans

Axial-flow fans with IP 54 ingress protection, external impeller, pressed metal blades, housed in aerodynamic tubes, complete with accident prevention grill. Six-pole electric motor with integrated thermal protector. Continuous fan speed control by pressure transducer.

2.8 Refrigerant circuit

Main components in the refrigerant circuit:

- refrigerant R410A
- electronic thermostatic valve,
- filter-drier,
- high safety pressure switches,
- low and high pressure transducers.

2.9 Power and control electrical panel:

Power and control electrical panel built in compliance with EN 60204-1/IEC 204-1, complete with:

- Compressor circuit breaker,
- Electronic controller,
- Numbered control circuit cables,
- Continuous fan speed control,
- Pump enabling relay,
- Fan start capacitor,
- System water pump protection fuse,
- Auxiliary circuit protection fuse,
- Fan protection fuse,
- Board power supply protection fuse,
- Spring terminal blocks for the control circuits,
- Remote ON/OFF terminals,
- Demand limit /night mode terminals
- Reduced electricity rate terminals
- Alarm/secondary pump/dehumidifier terminals,
- Buffer tank probe terminals

2.10 Water circuit:

Standard configuration includes the hydronic module with the following components: EC water pump, expansion tank, safety valve, air vent, anti-freeze electric heater, flow switch, water filter (delivered with the unit).

The configuration without hydronic module includes the following components: safety valve, air release valve, anti-freeze electric heater, flow switch, water filter (delivered with unit).

2.11 Versions

- **Basic version**
- Standard unit

2.12 Configurations

- **Standard unit**
- Standard unit for production of chilled water.

2.13 Accessories

- N-CM kit for managing chillers in cascade.
- N-RS RS485 serial card for ModBus protocol.
- Low-loss header: 35, 100 or 200 litres.
- Rubber vibration dampers
- Copper-Aluminum heat exchanger coils with epoxy treatment
- Copper-Copper heat exchanger coils

3. ELECTRONIC CONTROLLER

NADISYSTEM ensures dynamic control of water outlet temperature according to real needs in the building and the outside air temperature, optimising comfort and reducing wasted energy. Moreover, the controller modulates fan operation for optimum condensation, reducing noise at night.

NADISYSTEM also allows easy service, being interfaceable to supervision systems for remote maintenance by specialist technicians, as well as remote control of certain functions, such as:

- on/off
- shutdown due to electricity rate

Main functions

- Operating parameters with dedicated user and installer menus to configure the type of system
- Outside air temperature probe to control the system water temperature set point based on compensation curves. Fixed point operation also available.
- Cascaded management of up to 4 chillers (option).
- Alarm signals
- Frost protection management based on inside or outside air temperature or water temperature, to protect the system pipes and heat exchangers inside the unit.
- Night mode: is a system setting to limit maximum noise level of the unit. Noise level is reduced limiting maximum compressor frequency and fan speed.

The controller can manage up to four 4 chillers connected in cascade, by means of the remote keypad kit N-CM (optional). This configuration increases the capacity in applications with multiple occupied areas, such as hotels, schools, apartment blocks, offices and shopping centres. The units are managed in master-slave mode: the master unit processes the information and sends it to the slave units.

This ensures fine control over the capacity delivered, without decreasing performance, and more precise system sizing.

The controller also balances compressor operating hours based on time logic, activating the units in rotation, and where necessary excluding any units that are momentarily out of service, without interrupting operation of the cascade as a whole.



4. OPERATING CHARACTERISTICS

HIGH EFFICIENCY AND REDUCED CONSUMPTION

The i-BX air cooled chiller is fitted with DC inverter-driven compressor.

Inverter technology continuously controls compressor speed to ensure perfect adaptation to system load, modulating the cooling capacity delivered and consequently reducing power consumption and achieving the highest seasonal coefficients currently available on the market.

The seasonal coefficient of performance faithfully reflects the advantages in energy and economic terms of using the unit all year around, being the ratio between energy delivered and power consumed.

In terms of improving performance and reducing power consumption, the electronic thermostatic valve is an important component that maximises system efficiency.

Quick and effective adaptation by the electronic thermostatic valve to variations in load allows the compressor to always work at optimum efficiency, as well as extending compressor life.



TEMPERATURE CONTROL

The water temperature delivered to the cooling circuit is calculated by the controller and depends on the selected cooling and heating compensation curve.

A building's thermal requirements do not remain constant throughout the day or the year, but rather increase or decrease based on the outside air temperature.

It's therefore a waste of energy to keep the water at a constant temperature. The delivering of water at different temperatures to the terminals according to the outside air temperature allows to achieve high seasonal efficiency ratios and considerable savings in running costs. The compensation curve in cooling mode can be adjusted to allow correct heat pump operation according to the system (radiant panels, radiators, fan coils).

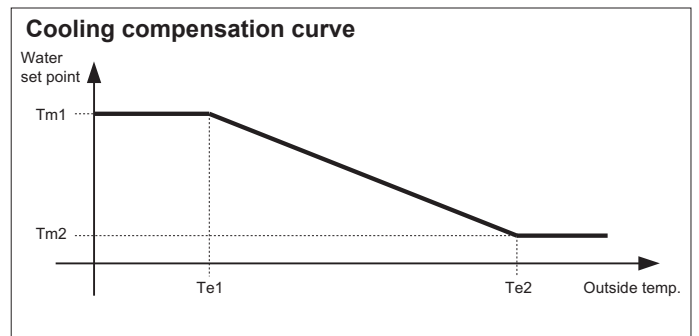

SYSTEM PUMP OPERATION

When reaching the system water temperature set point, the compressor stops and the system pump is activated periodically, so as to minimise energy consumption and ensure correct measurement of the water temperature. The pump on and off times can be set using a parameter, according to the type of system.

In systems with fan coils, the time between one ON/OFF cycle and the next should be reduced in order to avoid excessive cooling of the water, in heating operation, and if and if the system water content is equal to the minimum value shown in the paragraph on "Minimum and maximum system water content".

FROST PROTECTION

The frost protection function is active even when the chiller is OFF.

PRIMARY CIRCUIT FROST PROTECTION SYSTEM

The frost protection function is guaranteed by activation of the electric heater on the heat exchanger and the system pump. The pump and electric heater are activated when the water temperature (measured by the probe on the heat exchanger outlet) is less than 4.5°C, and are deactivated when the water temperature reaches +7°C.

FROST PROTECTION BASED ON OUTSIDE AIR TEMPERATURE

The system pump is activated according to the outside air temperature to prevent ice forming in the pipes.

The pump is activated if the outside air temperature is less than 4°C and deactivated when it rises back over 5°C.

ALARM SIGNALS

Correct unit operation and any alarms are displayed on the room thermostat, the latter by the  symbol.

The diagnostics functions include complete alarm management, with an alarm log (via service keypad) for more detailed analysis of unit behaviour.

5. ACCESSORIES

The accessories listed below are supplied separately.

METAL MESH WATER FILTER (standard with the unit)

This filter **MUST** be installed on the chiller return pipe to trap any impurities in the water circuit that may damage the unit's heat exchanger.

Characteristics	
Body	Brass
Finish	Sanded
Body gasket	Betaflex 71
Thread	ISO 228/1
Filter	AISI 304 stainless steel micro-perforated sheet metal
Hole pitch	DN25=1,5mm - DN32=2mm
Inscribed hole diameter	DN25=400micron - DN32=500micron
Number of holes per cm ²	DN25=150 - DN32=80

Dimensions			
DN		25	32
R	inch	1"	1" 1/4
L	mm	87	96
H	mm	60	68

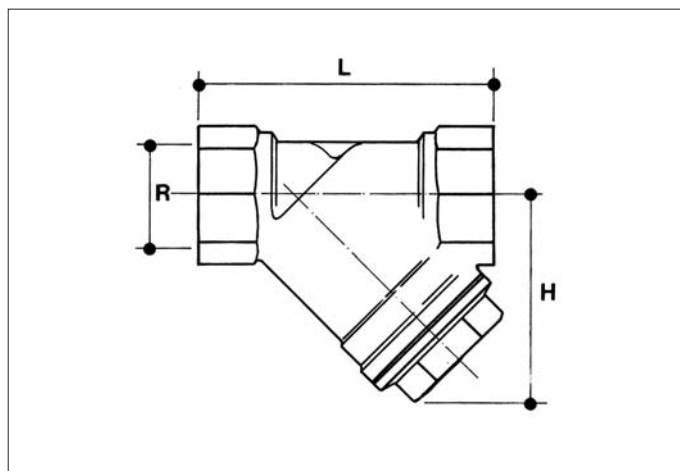

Pressure drop			
R	inch	1"	1" 1/4
Kv		11,08	17,00

VIBRATION DAMPERS

Used between the chiller and the support plane.

Vibration dampers made from rubber, elastomer and aluminium alloy casing for fastening to the floor.

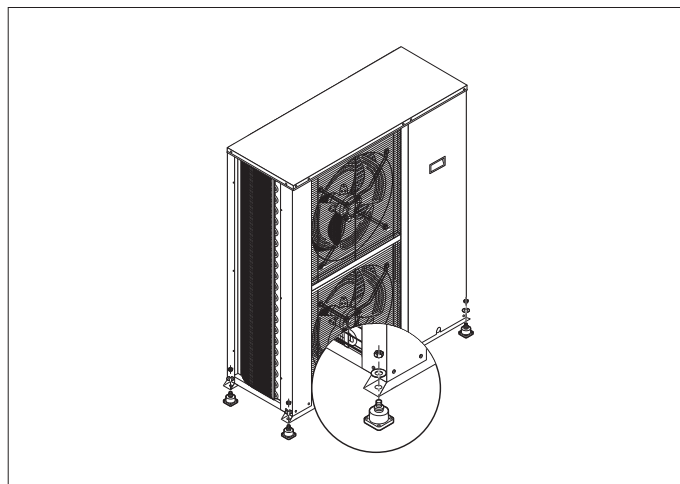

BTB STORAGE TANK

Storage tanks to be used in heating and cooling systems, to ensure minimum heat pump operating time in all operating conditions and avoid excessive starts and stops.

To be install under the unit on the heat pump return pipe.

In this case, make sure the available pressure head of the pump on the unit is sufficient to guarantee correct system operation.

Installing the storage tank may result in an increase in the overall dimensions of the unit. In particular, the overall height could increase by about 280 mm for BTB30 and 190mm for BTB60.



BT AND PT STORAGE TANKS

Storage tanks to be used in heating and cooling systems, to ensure minimum heat pump operating time in all operating conditions and avoid excessive starts and stops.

It can also be used to isolate the water circuit from the heat pump and to partially meet energy demand during periods in which the unit is shutdown due to the electricity rate.

For indoor installation.

Models available	Volume
BT35	35 litres
BT100	100 litres
BT200	200 litres

The diagram illustrates the use of the BT/TP storage tank as a low-loss header to separate the heat pump primary circuit from the secondary circuit to the terminal units.

This allows different flow-rates and temperatures to be managed depending on the type of terminal used.

Correctly sized, it guarantees the minimum water volume required by the heat pump.

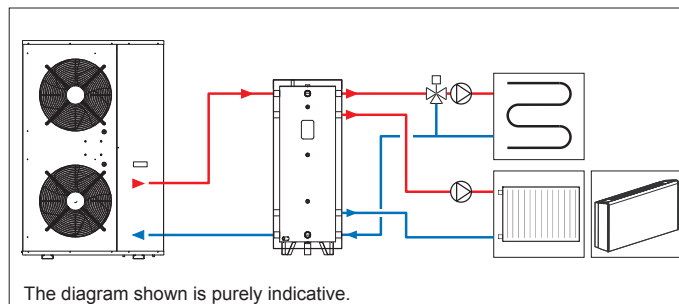

The diagram illustrates the use of the BT/TP storage tank as a storage tank on the heat pump return pipe so as to increase the volume of water available in the system, avoiding excessive starts and stops.

In this case, make sure the available pressure head of the pump on the unit is sufficient to guarantee correct system operation.

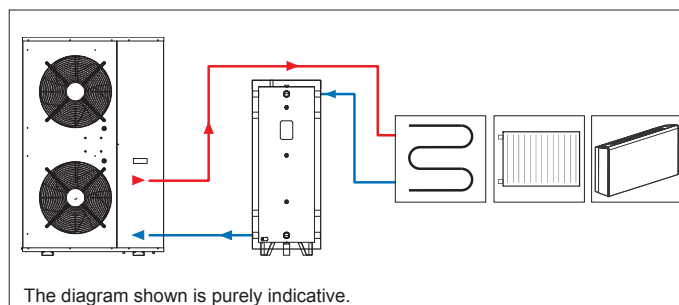

Technical specifications

The storage tanks are made from carbon steel plate welded using the best technology and undergo strict water pressure tests (9 bars, allowing an operating pressure of 6 bars).

Being a container of water for heating and cooling, this product does not require internal treatment, while the outside is coated with rustproof paint.

The tanks are protected on the outside with a closed cell elastomeric foam lining, 50 mm thick, with soft blue PVC exterior finish, for models BT 100/200 and TP300; polyethylene foam insulation, 10 mm thick, with metallic exterior finish for models BT35.

Dimensions - Model BT35

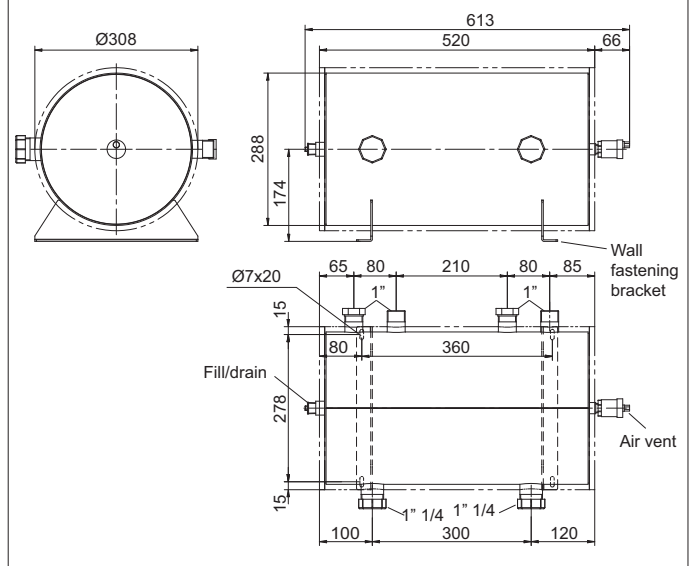

Volume	Storage tank dimensions											
	Di	d	Htot	A	B	C	D	E	F	G	K	I
litres	mm											
100	500	400	970	100	130	160	280	250	264	264	868	140
200	550	450	1410	100	130	160	280	430	374	386	1298	170
300	700	600	1235	100	130	160	280	320	321	332	1133	200

Volume	Fittings				
	1	2	3	4	5
litres	inch				
100	1"1/4	2"	1/2"	1/2"	3/8"
200	1"1/4	2"	1/2"	1/2"	3/8"
300	1"1/4	2"	1/2"	1/2"	3/8"

Pos.	Description
1A	Heat pump outlet
1B	Heat pump return
1C	System outlet
1D	System return
1E- G	Supplementary source outlet
1F-1H	Supplementary source return
2	Electric heater attachment
3	Probe socket
4	Drain/load
5	Vent

Dimensions - Model BT100, BT200, TP300

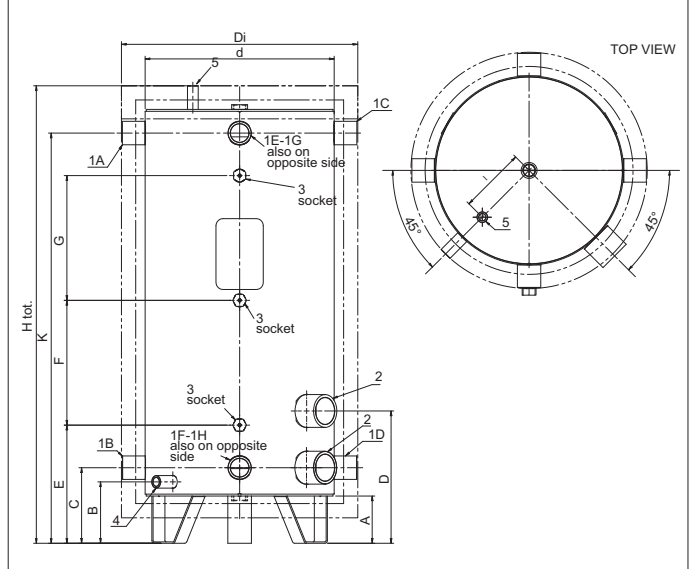

N-CM CASCADE MANAGEMENT KEYPAD

The N-CM remote keypad allows cascaded connection of up to 4 units. This configuration increases the capacity in applications with multiple occupied areas, such as hotels, schools, apartment blocks, offices and shopping centres.

The cascade configuration is viable if the units have the same capacity and if the control software release is the same on each unit.

The units are managed in master-slave mode: the master unit processes the information and sends it to the slave units. This ensures fine control over the capacity delivered, without decreasing performance, and more precise system sizing.

The controller also balances compressor operating hours based on time logic, activating the units in rotation, and where necessary excluding any units that are momentarily out of service, without interrupting operation of the cascade as a whole.

If the malfunctioning unit is the master, the operating parameters are transferred to another unit in the cascade, thus restoring partial operation. The N-CM keypad can also display the operation of each chiller connected to the cascade.

The N-CM keyboard can be used for remote control of a single unit.

NOTE: For cascade configuration, the N-CM kit must be coupled with:

- The kit n° 1 temperature probe (code 7390049200)



System architecture

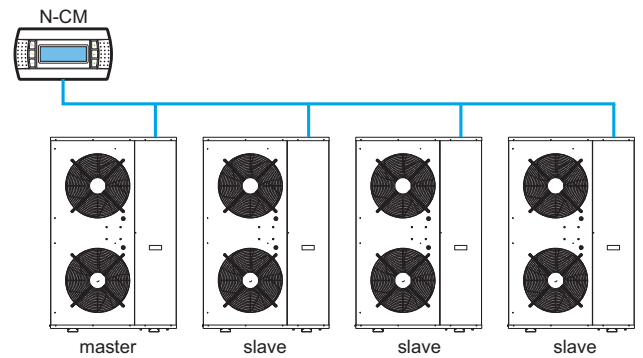

Dimensions

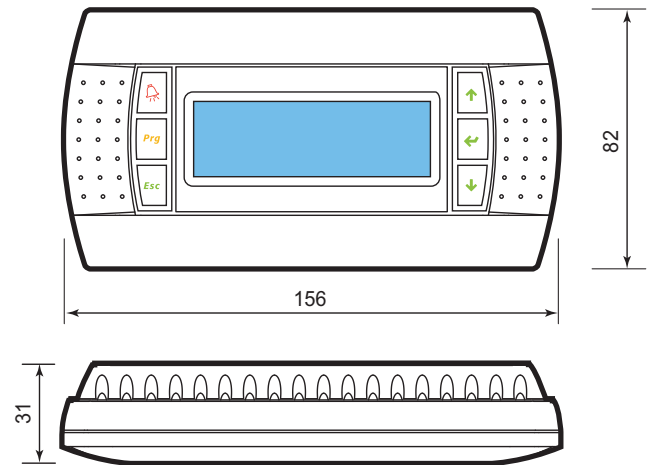

N-RS RS485 SERIAL CARD

The N-RS is an optional card for directly interfacing the heat pumps to an RS485 network.

The card guarantees opto-isolation of the controller from the RS485 serial network.

The maximum baud rate available is 19200 baud.

The optional card is fitted in the comb connector on the unit's board.

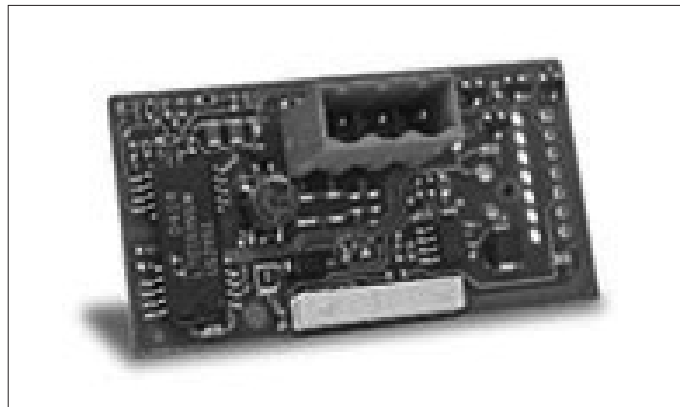

6. GENERAL TECHNICAL DATA

i-BX		004	006	008	010	013	010	013	015	020	025	
Power supply	V/ph/Hz	230/1/50	230/1/50	230/1/50	230/1/50	230/1/50	400/3+N/50	400/3+N/50	400/3+N/50	400/3+N/50	400/3+N/50	
PERFORMANCE												
COOLING ONLY (GROSS VALUE)												
Cooling capacity	(1)	kW	4,30	6,11	8,10	10,6	12,9	10,7	13,3	15,5	20,6	25,0
Total power input	(1)	kW	1,55	2,12	2,82	3,64	4,74	3,64	4,74	5,44	7,20	8,69
EER	(1)	kW/kW	2,77	2,88	2,87	2,91	2,72	2,94	2,81	2,85	2,86	2,88
ESEER	(1)	kW/kW	4,20	4,36	4,70	4,29	4,55	4,36	4,57	4,14	4,12	4,26
COOLING ONLY (EN14511 VALUE)												
Cooling capacity	(1)(2)	kW	4,30	6,11	8,11	10,6	12,9	10,7	13,3	15,5	20,6	25,0
EER	(1)(2)	kW/kW	2,82	2,92	2,92	2,92	2,74	2,95	2,82	2,87	2,88	2,90
ESEER	(1)(2)	kW/kW	4,53	4,60	5,08	4,34	4,69	4,42	4,69	4,20	4,20	4,36
Cooling energy class			C	B	B	B	C	B	C	C	C	B
EXCHANGERS												
HEAT EXCHANGER USER SIDE IN REFRIGERATION												
Water flow	(1)	l/s	0,21	0,29	0,39	0,51	0,62	0,51	0,64	0,74	0,99	1,20
Available unit's head	(1)	kPa	50,7	38,1	61,8	55,6	55,3	52,7	51,7	76,7	66,3	60,3
REFRIGERANT CIRCUIT												
Compressors nr.		N°	1	1	1	1	1	1	1	1	1	1
Number of capacity steps		N°	0	0	0	0	0	0	0	0	0	0
No. Circuits		N°	1	1	1	1	1	1	1	1	1	1
Regulation			STEPLESS	STEPLESS	STEPLESS	STEPLESS	STEPLESS	STEPLESS	STEPLESS	STEPLESS	STEPLESS	STEPLESS
Min. capacity step		%	25	25	25	25	25	25	25	25	25	25
Refrigerant			R410A	R410A	R410A	R410A	R410A	R410A	R410A	R410A	R410A	R410A
Refrigerant charge		kg	1,45	2,10	3,55	3,60	3,65	3,60	3,65	2,75	4,15	5,75
Oil charge		kg	0,35	0,35	0,40	0,87	1,40	0,87	1,40	1,40	1,40	1,40
Rc (ASHRAE)	(3)	kg/kW	0,34	0,35	0,44	0,34	0,29	0,34	0,28	0,31	0,33	0,28
FANS												
Fans number		N°	1	1	1	2	2	2	2	2	1	2
Air flow		m³/s	1,02	0,98	0,99	1,74	1,58	1,74	1,70	1,64	2,26	3,76
Fans power input		kW	0,12	0,12	0,12	0,12	0,12	0,12	0,12	0,12	0,60	0,40
NOISE LEVEL												
Sound Pressure	(4)	dB(A)	33	34	35	38	39	38	39	43	43	43
Sound power level in cooling	(5)(6)	dB(A)	64	65	66	69	70	69	70	74	74	75
SIZE AND WEIGHT												
A	(7)	mm	900	900	900	900	900	900	900	900	1450	1450
B	(7)	mm	370	370	420	420	420	420	420	420	550	550
H	(7)	mm	940	940	1240	1240	1240	1240	1240	1390	1200	1700
Operating weight	(7)	kg	75	80	95	110	125	110	125	135	190	250

Notes:

1 Plant (side) cooling exchanger water (in/out) 12,0°C/7,0°C; Source (side) heat exchanger air (in) 35,0°C.

2 Values in compliance with EN14511-3:2013.

3 Rated in accordance with AHRI Standard 550/590 (2011 with addendum 1).

4 Average sound pressure level at 10m distance, unit in a free field on a reflective surface; non-binding value calculated from the sound power level.

5 Sound power on the basis of measurements made in compliance with ISO 9614.

6 Sound power level in cooling, outdoors.

7 Unit in standard configuration/execution, without optional accessories.

- Not available

Certified data in EUROVENT

i-BX		030	035
Power supply		V/ph/Hz 400/3+N/50 400/3+N/50	
PERFORMANCE			
COOLING ONLY (GROSS VALUE)			
Cooling capacity	(1)	kW	29,8 35,1
Total power input	(1)	kW	10,0 11,8
EER	(1)	kW/kW	2,98 2,97
ESEER	(1)	kW/kW	4,15 4,29
COOLING ONLY (EN14511 VALUE)			
Cooling capacity	(1)(2)	kW	29,9 35,2
EER	(1)(2)	kW/kW	3,01 3,00
ESEER	(1)(2)	kW/kW	4,27 4,39
Cooling energy class		B	B
EXCHANGERS			
HEAT EXCHANGER USER SIDE IN REFRIGERATION			
Water flow	(1)	l/s	1,43 1,68
Available unit's head	(1)	kPa	90,0 73,5
REFRIGERANT CIRCUIT			
Compressors nr.		N°	1 1
Number of capacity steps		N°	0 0
No. Circuits		N°	1 1
Regulation			STEPLESS STEPLESS
Min. capacity step		%	25 25
Refrigerant			R410A R410A
Refrigerant charge		kg	6,45 6,90
Oil charge		kg	2,30 2,30
Rc (ASHRAE)	(3)	kg/kW	0,27 0,24
FANS			
Fans number		N°	2 2
Air flow		m³/s	4,20 4,86
Fans power input		kW	0,55 0,52
NOISE LEVEL			
Sound Pressure	(4)	dB(A)	44 45
Sound power level in cooling	(5)(6)	dB(A)	76 77
SIZE AND WEIGHT			
A	(7)	mm	1450 1700
B	(7)	mm	550 650
H	(7)	mm	1700 1700
Operating weight	(7)	kg	270 305

Notes:

1 Plant (side) cooling exchanger water (in/out) 12,0°C/7,0°C; Source (side) heat exchanger air (in) 35,0°C.

2 Values in compliance with EN14511-3:2013.

3 Rated in accordance with AHRI Standard 550/590 (2011 with addendum 1).

4 Average sound pressure level at 10m distance, unit in a free field on a reflective surface; non-binding value calculated from the sound power level.

5 Sound power on the basis of measurements made in compliance with ISO 9614.

6 Sound power level in cooling, outdoors.

7 Unit in standard configuration/execution, without optional accessories.

- Not available

Certified data in EUROVENT

7. ENERGY EFFICIENCY

SEASONAL EFFICIENCY IN COOLING (Reg. EU 2016/2281)

Ambient refrigeration

i-BX			004	006	008	010	013	010	013	015	020	025	030	035
Prated,c	(1)	kW	4,3	6,11	8,11	10,6	12,9	10,7	13,3	15,5	20,6	25	29,9	35,2
SEER	(1)(2)		4,38	4,43	4,93	4,39	4,78	4,46	4,8	4,31	4,31	4,52	4,52	4,57
Performance	(1)(3)	%	172	174	194	172	188	176	189	169	169	178	178	180

Notes:

(1) Seasonal energy efficiency of the cooling environment [REGULATION (EU) N. 2016/2281]

(2) Seasonal space heating energy index

(3) Seasonal energy efficiency of the space cooling

The units highlighted in this publication contain HFC R410A [GWP100 2088] fluorinated greenhouse gases.

Certified data in EUROVENT

8. OPERATING LIMITS

COOLING

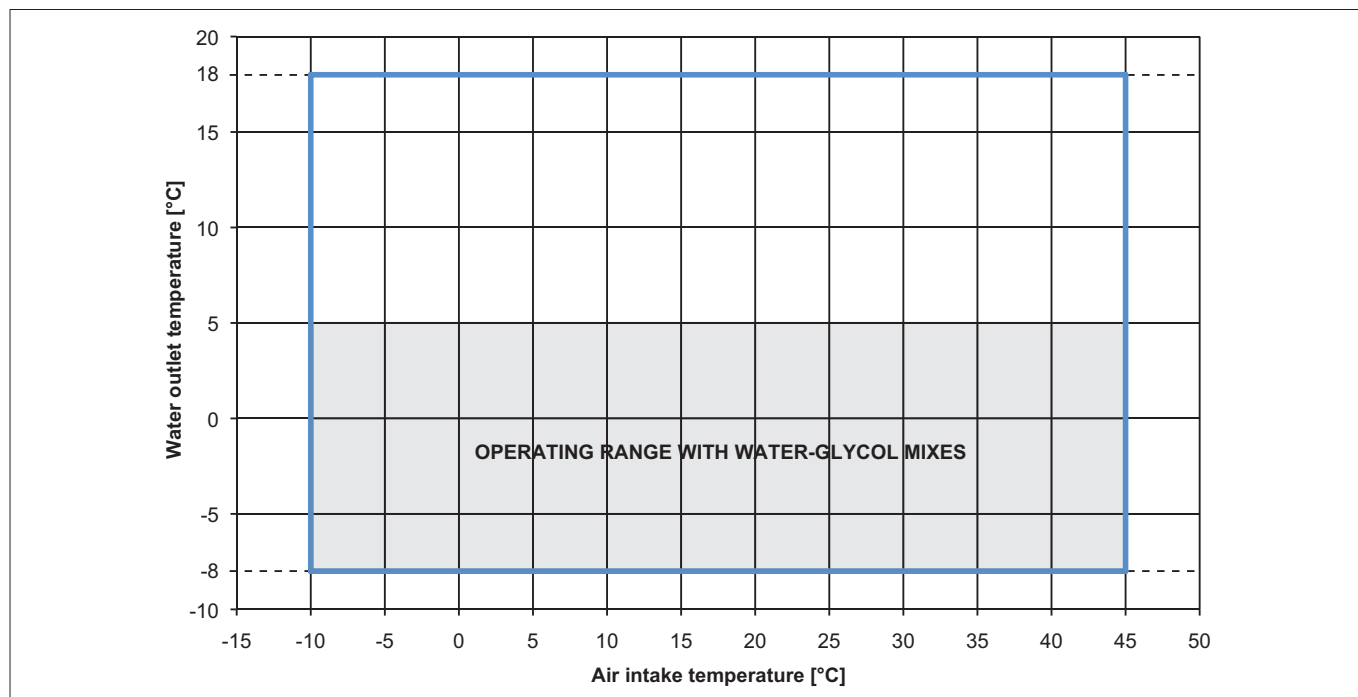

Operation in cooling mode:

System circuit temperature difference, minimum 3°K, maximum 8°K

Maximum glycol content 40%

9. ETHYLENE GLYCOL MIXTURE

Ethylene glycol and water mixture, used as a heat-conveying fluid, cause a variation in unit performance. For correct data, use the factors indicated in the following table.

	Freezing point (°C)							
	0	-5	-10	-15	-20	-25	-30	-35
	Ethylene glycol percentage by weight							
	0	12%	20%	30%	35%	40%	45%	50%
cPf	1	0,985	0,98	0,974	0,97	0,965	0,964	0,96
cQ	1	1,02	1,04	1,075	1,11	1,14	1,17	1,2
cdp	1	1,07	1,11	1,18	1,22	1,24	1,27	1,3

cPf: cooling power correction factor

cQ: flow correction factor

cdp: pressure drop correction factor

For data concerning other kind of anti-freeze solutions (e.g. propylene glycol) please contact our Sale Department.

10. FOULING FACTORS

Performances are based on clean condition of tubes (fouling factor = 1). For different fouling values, performance should be adjusted using the correction factors shown in the following table.

FOULING FACTORS	EVAPORATOR			CONDENSER/RECOVERY			DESUPERHEATER
ff (m ² °CW)	F1	FK1	KE [°C]	F2	FK2	KC [°C]	R3
0	1,000	1,000	0,0	1,000	1,000	0,0	1,000
1,80 x 10 ⁻⁵	1,000	1,000	0,0	1,000	1,000	0,0	1,000
4,40 x 10 ⁻⁵	1,000	1,000	0,0	0,990	1,030	1,0	0,990
8,80 x 10 ⁻⁵	0,960	0,990	0,7	0,980	1,040	1,5	0,980
13,20 x 10 ⁻⁵	0,944	0,985	1,0	0,964	1,050	2,3	0,964
17,20 x 10 ⁻⁵	0,930	0,980	1,5	0,950	1,060	3,0	0,950

ff: fouling factors

f1 - f2: potential correction factors

fk1 - fk2: compressor power input correction factors

r3: capacity correction factors

KE: minimum condenser outlet temperature increase

KC: maximum condenser outlet temperature decrease

11. HYDRAULIC DATA

Water flow and pressure drop

Water flow in the plant (side) exchanger is given by:

$$Q = P / (4,186 \times Dt)$$

Q: water flow (l/s)

Dt: difference between inlet and outlet water temp. (°C)

P: heat exchanger capacity (kW)

Pressure drop is given by:

$$Dp = K \times (3,6 \times Q)^2 / 1000$$

Q: water flow (l/s)

Dp: pressure drop (kPa)

K: unit size ratio

SIZE	Power supply V/ph/Hz	HEAT EXCHANGER USER SIDE				
		K	Q min l/s	Q max l/s	C.A.S. l	C.a. min l
i-BX /004	230/1/50	15500	0,14	0,36	1,00	10,0
i-BX /006	230/1/50	13500	0,19	0,50	1,00	15,0
i-BX /008	230/1/50	7500	0,25	0,64	1,50	19,0
i-BX /010	230/1/50	4800	0,31	0,81	1,80	24,0
i-BX /013	230/1/50	3300	0,39	1,06	2,00	31,0
i-BX /010	400/3+N/50	4800	0,33	0,86	1,80	26,0
i-BX /013	400/3+N/50	3300	0,39	1,06	2,00	32,0
i-BX /015	400/3+N/50	2850	0,47	1,22	2,10	37,0
i-BX /020	400/3+N/50	1900	0,61	1,64	2,50	49,0
i-BX /025	400/3+N/50	1100	0,75	2,00	3,10	60,0
i-BX /030	400/3+N/50	700	0,89	2,39	4,20	71,0
i-BX /035	400/3+N/50	650	1,06	2,81	4,90	84,0

Q min: minimum water flow admitted to the heat exchanger

Q max: maximum water flow admitted to the heat exchanger

C.a. min: minimum water content admitted in the plant

C.A.S.: Exchanger water content

PRESSURE DROP, VERSION WITHOUT PUMP

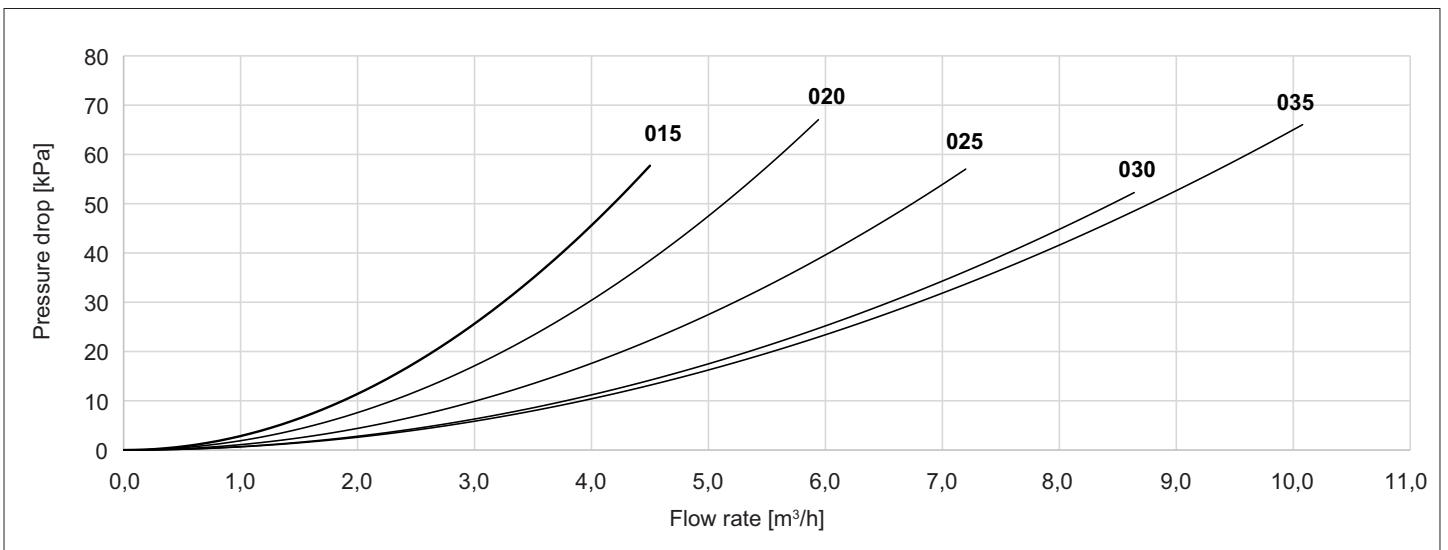
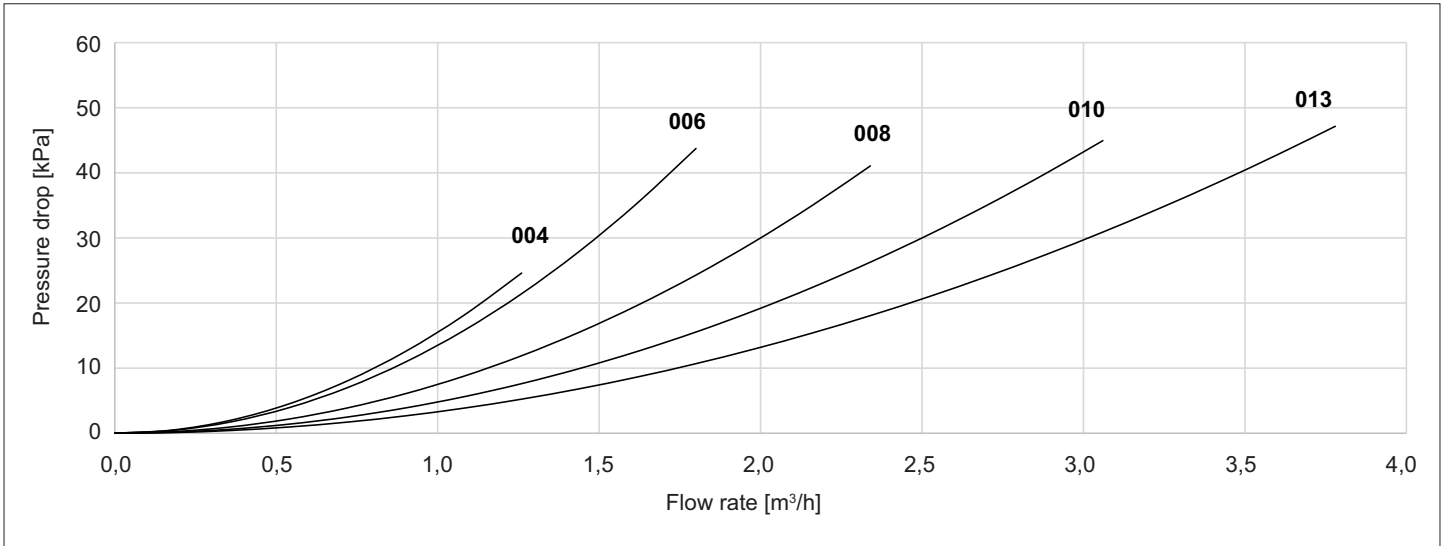

12. MINIMUM AND MAXIMUM SYSTEM WATER CONTENT

Minimum system water content

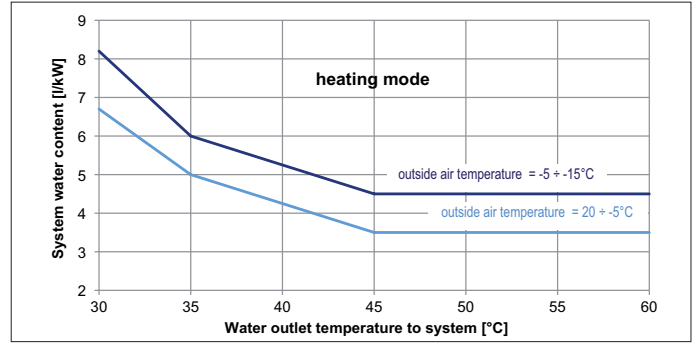
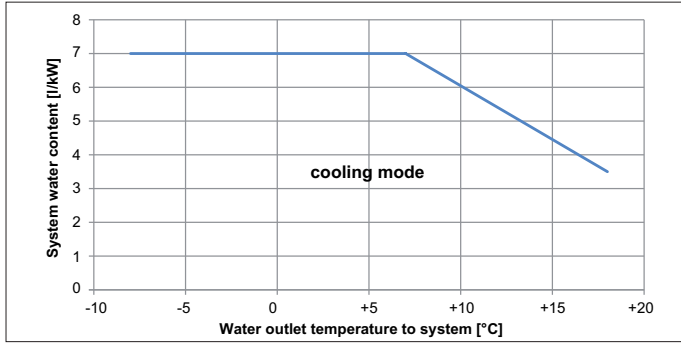

Minimum water content: in the case of i-BX-N units (heat pump, reversible), the highest value between refrigeration and heating operation must be considered. Use water / glycol mixture for water temperature below + 5°C.

Maximum system water content

The heat pumps are fitted as standard with an expansion vessel and safety valve. The maximum system water content depends on the capacity of the expansion vessel (see **table 2**) and the calibration of the safety valve (see **table 3**).

Tab. 2	Size	004	006	008	010	013	015	020	025	030	035
	Expansion vessel	Lt		2				5		8	

Tab. 3	Size	004	006	008	010	013	015	020	025	030	035
	Safety valve	kPa									
		600									

The expansion vessel is suitable for the radiant panel system, hydronic terminal system and radiator system with following **installation maximum water content**.

If the volume of water in the system is higher, an additional, correctly sized expansion vessel is required.

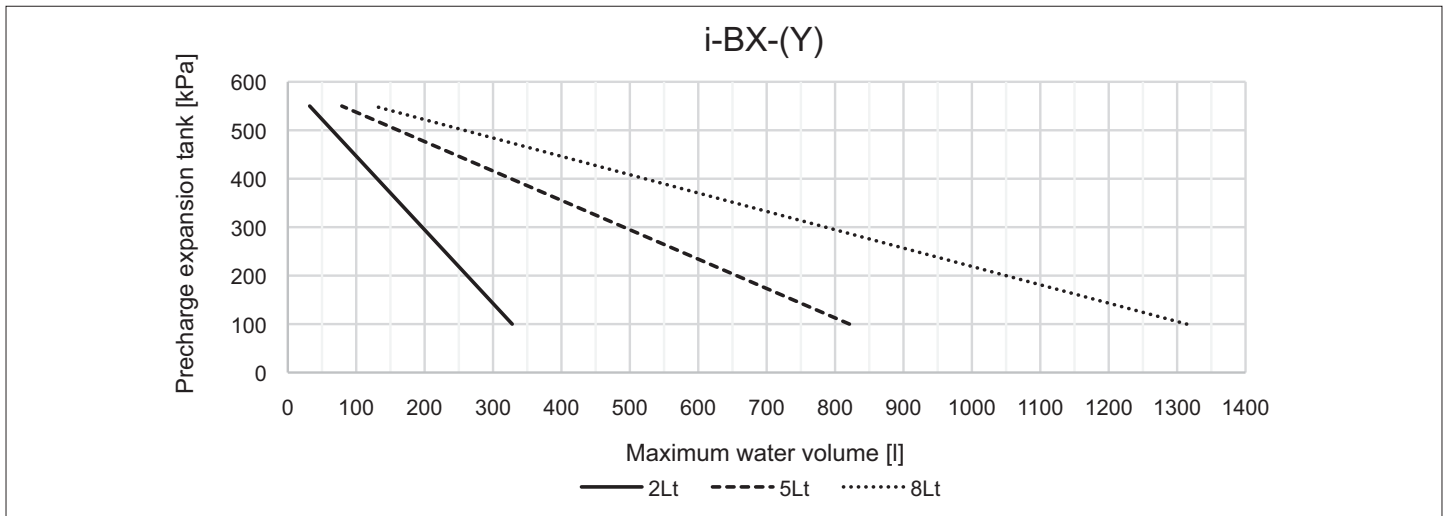

Expansion vessel calibration

The expansion vessels are pre-charged to a standard pressure of 1 bar.

The pre-charge pressure is chosen depending on the maximum difference in height between the system terminal and the heat pump, as shown in the figure.

The maximum height must not exceed 55 metres due to the maximum vessel pre-charge pressure of 6 bars.

Make sure that the system terminal at the lowest point H1 can withstand the pressure of the water column at that point.

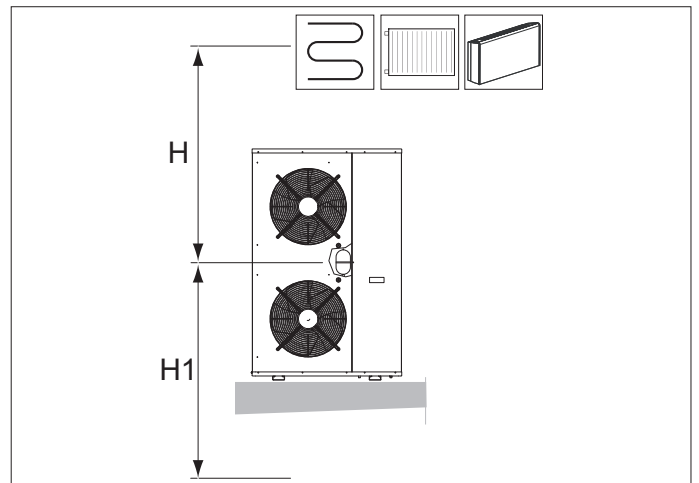

13. SYSTEM PUMP CURVES

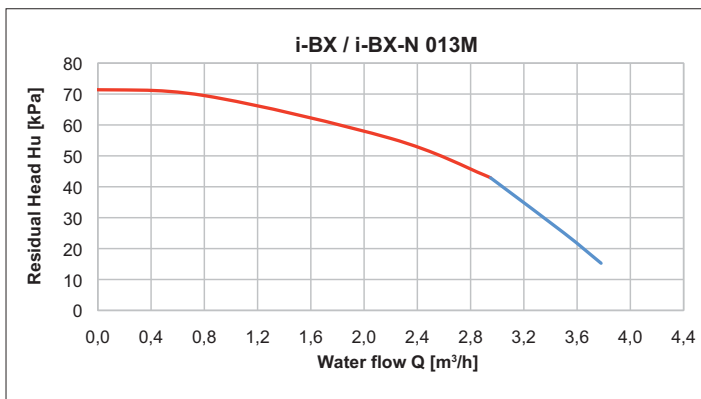
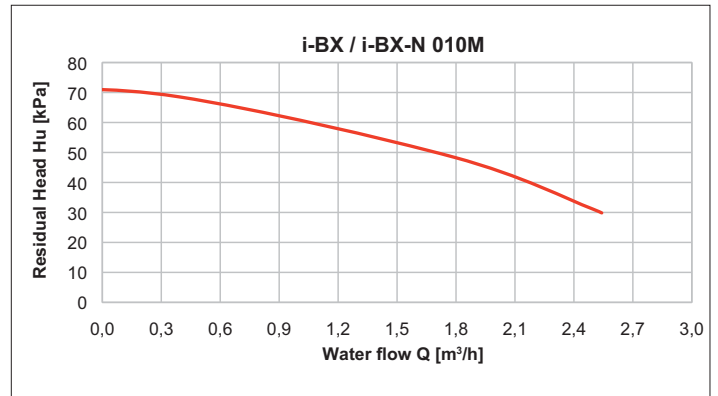
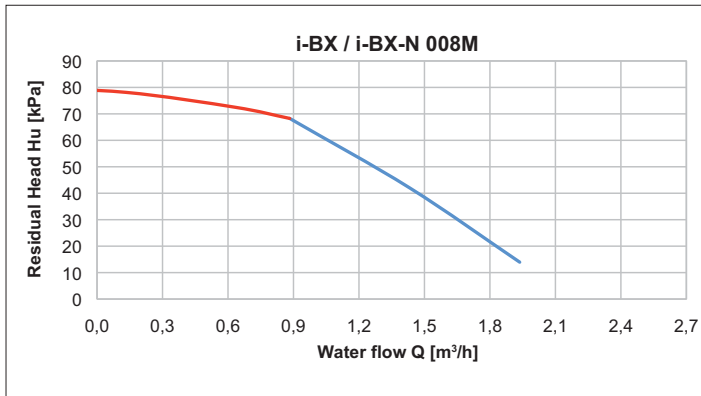
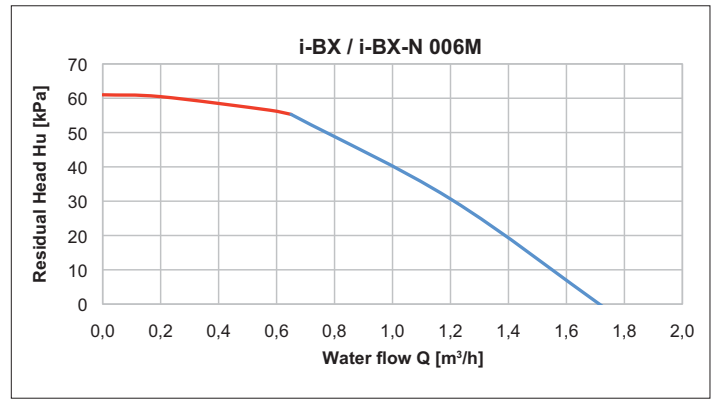
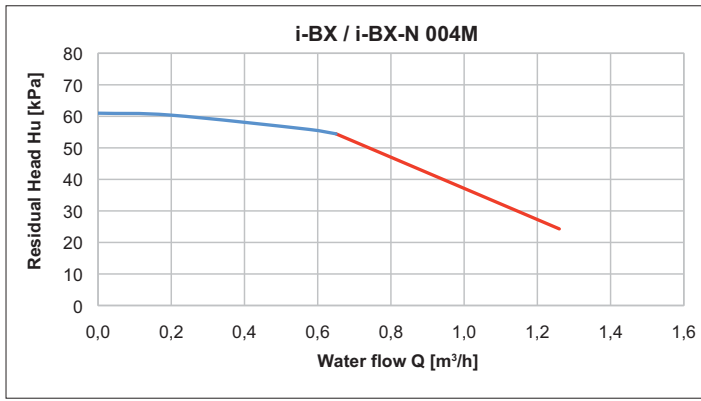

The pressure head values refer to the pressure available at the connections to the unit.

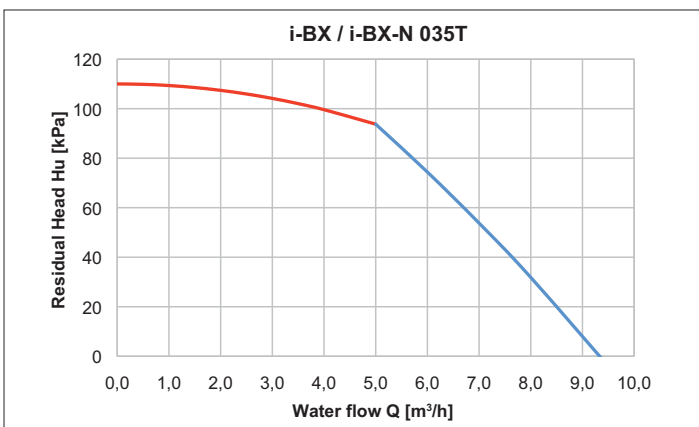
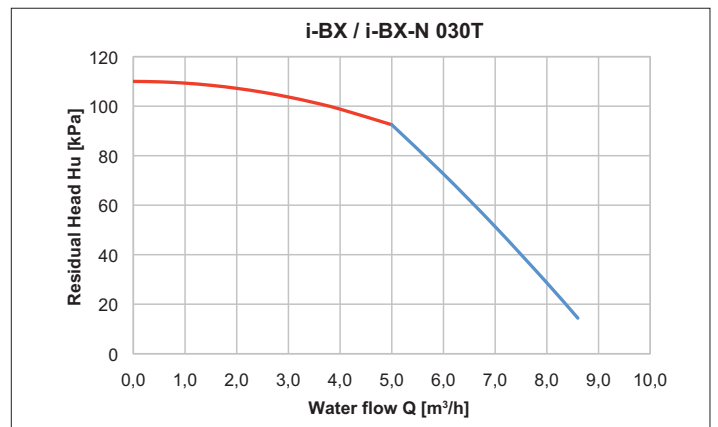
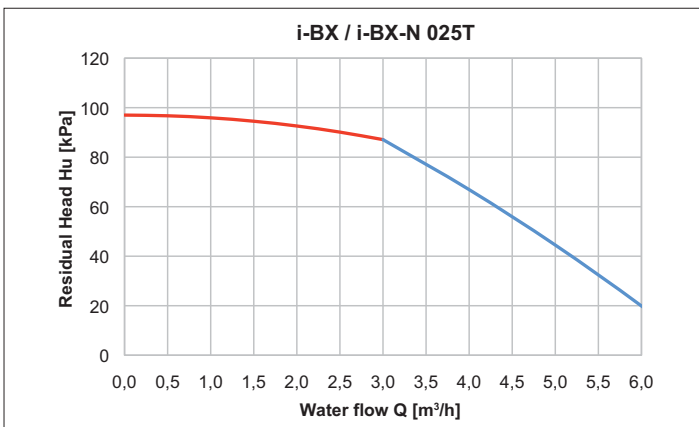
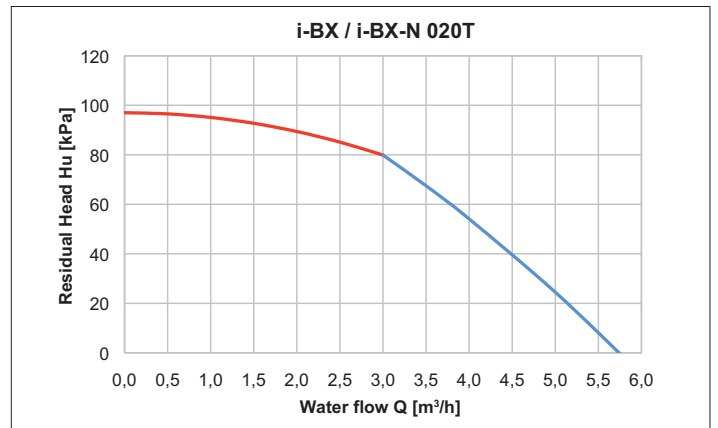
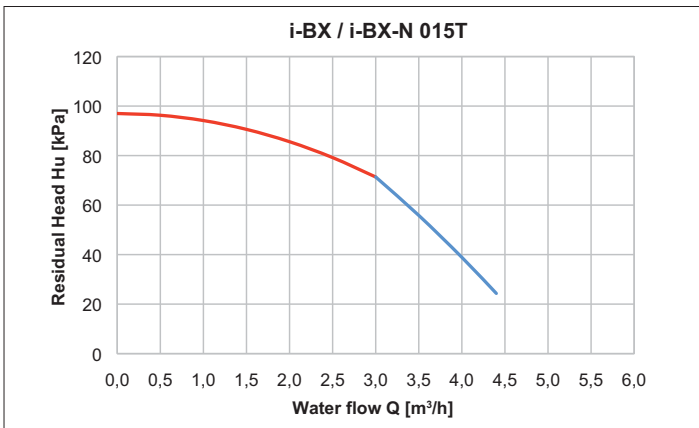
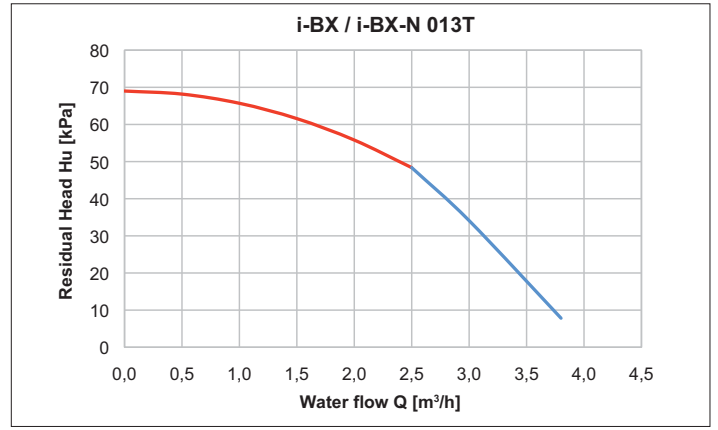
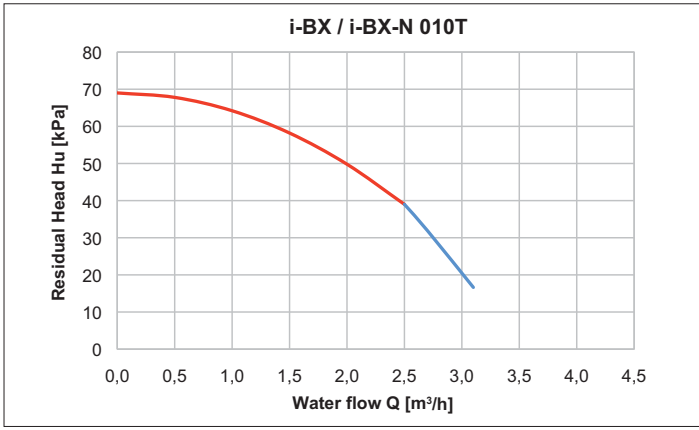

The pressure head values refer to the pressure available at the connections to the unit.

14. HYDRONIC GROUP

(HEAT EXCHANGER USER SIDE - HYDRONIC KIT 1 PUMP 2 POLES LH)

SIZE	CH		PUMP					CH
	Pfgross	Qfgross	Rif.	Model	N.	F.L.A.	F.L.I.	HU
	[kW] (1)	[l/s] (1)			Pole	[A]	[kW]	[kPa]
004	4,30	0,21	A1	YONOS CS 6	0	0	0,04	50,7
006	6,11	0,29	A2		0	0	0,04	38,1
008	8,10	0,39	B1	YONOS CS 8	0	0	0,08	61,8
010	10,6	0,51	D1	YONOS PARA HIGH FLOW 7	0	1	0,12	55,6
	10,7	0,51		YONOS PARA HF /7	0	1	0,12	52,7
013	12,9	0,62	F1	YONOS PARA HIGH FLOW 7	0	1	0,12	55,3
	13,3	0,64		YONOS PARA HF /7	0	1	0,12	51,7
015	15,5	0,74	G1	YONOS PARA HF /10	0	1	0,19	76,7
020	20,6	0,99	G2					66,3
025	25,0	1,20	G3					60,3
030	29,8	1,43	H1	YONOS PARA HF /12	0	1	0,31	90,0
035	35,1	1,68	H2					73,5

(1) Values refer to nominal conditions
 CH Cooling mode
 Pf Cooling capacity unit (Cooling mode)
 Pt Heating capacity unit (Heating mode)

Q Plant (side) exchanger water flow
 F.L.I. Pump power input
 F.L.A. Pump running current
 HU Pump residual pressure head (Units with hydronic group without mains filter)

15. UTILITY WATER CIRCUIT CONNECTION DIAGRAM

System water circuit connection diagram, i-BX version without pump

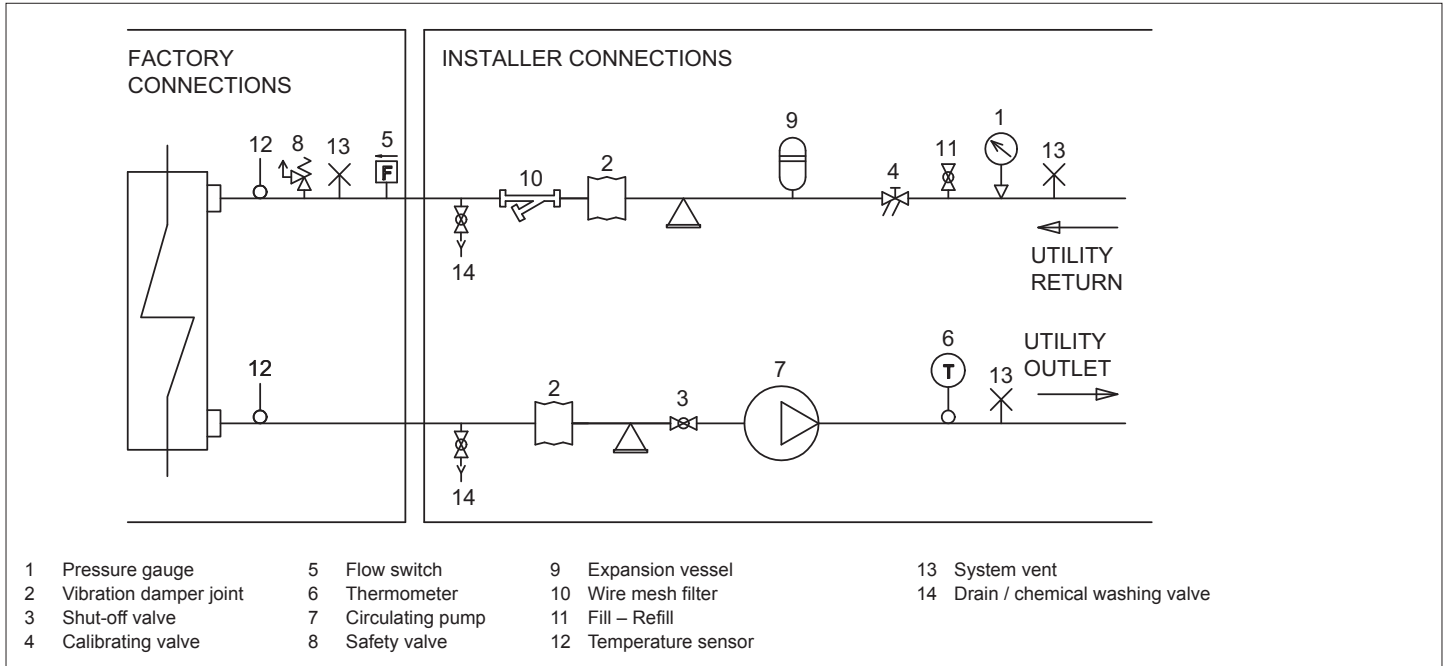

System water circuit connection diagram, i-BX with pump

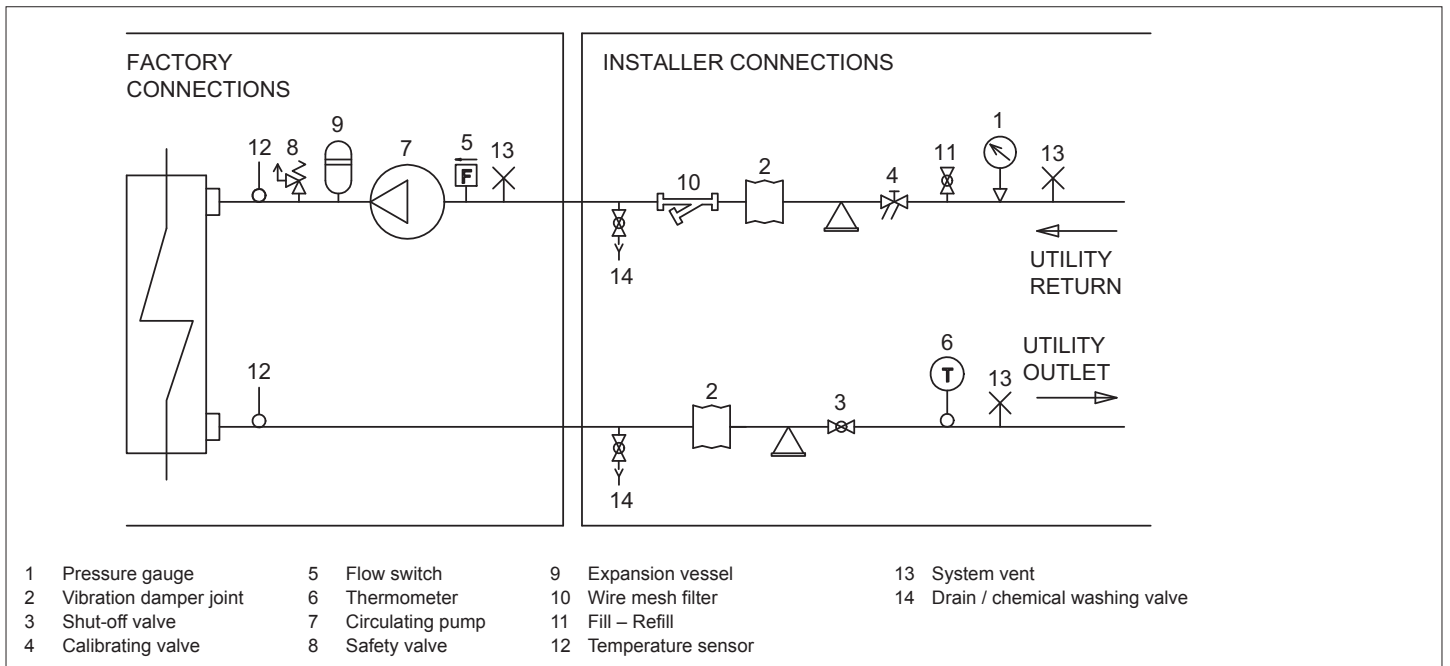

16. ELECTRICAL DATA

SIZE	Power supply V/ph/Hz	Maximum values								
		n	Compressor			Fans (1)		Total (1)(2)		
			F.L.I. [kW]	F.L.A. [A]	L.R.A. [A]	F.L.I. [kW]	F.L.A. [A]	F.L.I. [kW]	F.L.A. [A]	S.A. [A]
004	230/1/50	0	1,877	8,05		0,12	1	1,94	8	0
006	230/1/50	0	2,734	11,65		0,12	1	2,74	12	0
008	230/1/50	0	3,563	15,45		0,12	1	3,67	16	0
010	230/1/50	0	4,843	21,6		0,12	1	4,93	23	1
013	230/1/50	0	6,4	24,3		0,12	1	6,53	25	1
010	230/1/50	0	4,843	21,6		0,12	1	4,93	23	1
013	230/1/50	0	6,4	24,3		0,12	1	6,53	25	1
015	400/3+N/50	1	7,0	15,1	0	0,12	1	7,39	18	1
020	400/3+N/50	1	8,6	16,5	0	0,60	3	9,39	20	1
025	400/3+N/50	1	10,1	22,9	0	0,40	2	11,3	29	1
030	400/3+N/50	1	12,2	22,2	0	0,55	3	13,7	29	1
035	400/3+N/50	1	14,5	32,4	0	0,52	3	16,0	39	1

F.L.I.: Full load power

F.L.A.: Full load current

L.R.A.: Locked rotor amperes for single compressor

S.A.: Inrush current

(1) Values calculated referring to the version with the maximum number of fans working at the max absorbed current

(1)(2) Safety values to be considered when cabling the unit for power supply and line-protections

Data valid for standard units without any additional option.

Plant (side) cooling exchanger water (in/out) 12,0°C/7,0°C; Source (side) heat exchanger air (in) 35,0°C.

Voltage tolerance: 10%

Maximum voltage unbalance: 3%

Give the typical operating conditions of units designed for outdoor installation, which can be associated (according to reference document IEC 60721) to the following classes:

- climatic conditions class 4K4H: air temperature range from -20 up to 55°C (*), relative humidity range from 4 up to 100%, with possible precipitations, at air pressure from 70 and 106 kPa and a maximum solar radiation of 1120 W/m²

- special climatic conditions negligible

- biological conditions class 4B1 and 4C2: locations in a generic urban area

- mechanically active substances class 4S2: locations in areas with sand or dust representative of urban areas

- mechanical conditions class 4M1: locations protected from significant vibrations or shocks

The required protection level for safe operation, according to reference document IEC 60529, is IP43XW (protection against access, to the most critical unit's parts, of external devices with diameter larger than 1 mm and rain).

The unit can be considered IP44XW protected, i.e. protected against access of external devices (with diameter larger than 1 mm) and water in general.

(*) for the unit's operating limits, see "selection limits" section

17. FULL LOAD SOUND LEVEL

SOUND POWER LEVEL IN COOLING									
SIZE	Octave band [Hz]								Total sound level dB(A)
	63	125	250	500	1000	2000	4000	8000	
	Sound power level dB								
004	64	65	63	62	57	56	52	41	64
006	64	65	64	62	58	59	53	42	65
008	67	68	65	66	59	56	52	48	66
010	70	71	68	69	62	59	55	49	69
013	71	72	69	70	63	60	56	50	70
010	70	71	68	69	62	59	55	49	69
013	71	72	69	70	63	60	56	50	70
015	73	74	63	74	67	65	64	52	74
020	73	74	63	74	67	65	64	52	74
025	73	74	65	75	68	66	65	52	75
030	74	75	66	76	69	67	66	53	76
035	75	76	67	77	70	68	67	54	77

Working conditions

Plant (side) cooling exchanger water (in/out) 12,0°C/7,0°C; Source (side) heat exchanger air (in) 35,0°C.

Sound power on the basis of measurements made in compliance with ISO 9614.

Such certification refers specifically to the sound Power Level in dB(A). This is therefore the only acoustic data to be considered as binding.

Sound power level in cooling, outdoors.

SOUND PRESSURE LEVEL									
SIZE	Octave band [Hz]								Total sound level dB(A)
	63	125	250	500	1000	2000	4000	8000	
	Sound pressure level dB								
004	33	34	32	31	26	25	21	10	33
006	33	34	33	31	27	28	22	11	34
008	36	37	34	35	28	25	21	17	35
010	39	40	37	38	31	28	24	18	38
013	40	41	38	39	32	29	25	19	39
010	39	40	37	38	31	28	24	18	38
013	40	41	38	39	32	29	25	19	39
015	42	43	32	43	36	34	33	21	43
020	42	43	32	43	36	34	33	21	43
025	41	42	33	43	36	34	33	20	43
030	42	43	34	44	37	35	34	21	44
035	43	44	35	45	38	36	35	22	45

Working conditions

Plant (side) cooling exchanger water (in/out) 12,0°C/7,0°C; Source (side) heat exchanger air (in) 35,0°C.

Average sound pressure level at 10m distance, unit in a free field on a reflective surface; non-binding value calculated from the sound power level.

18. POSITION OF THE WATER CONNECTIONS

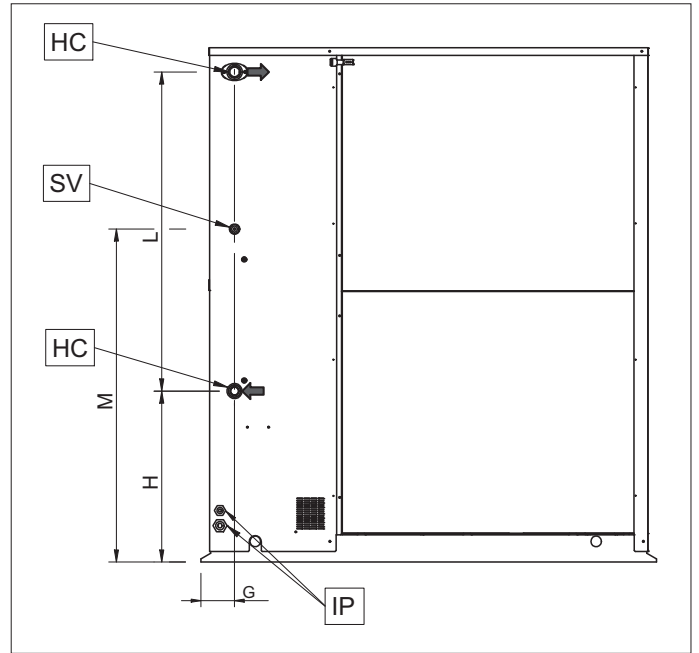
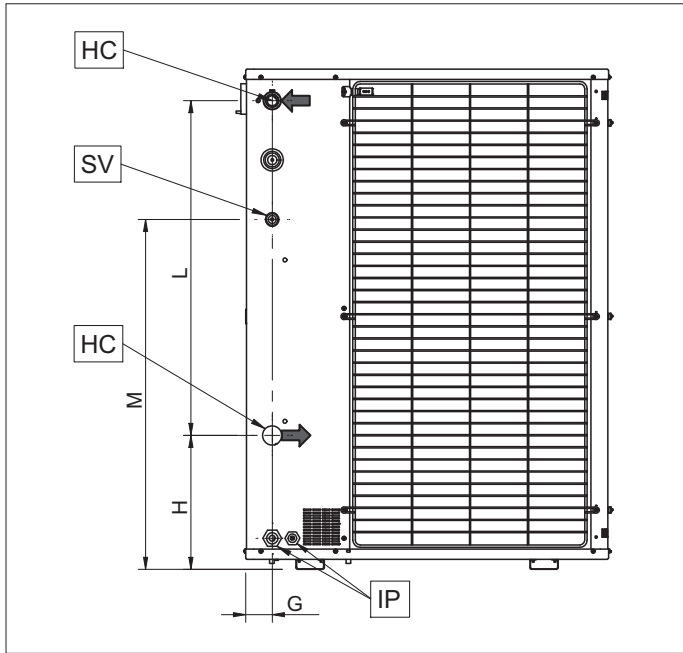

HC HYDRAULIC CONNECTIONS
SV SAFETY VALVE DISCHARGE

IP POWER SUPPLY INLET
OC CONDENSATE DRAIN OUTLET

Dimensions	G	H	L	M	HC
	[mm]	[mm]	[mm]	[mm]	Ø
i-BX-(Y) 004	66	142	720	676	1"
i-BX-(Y) 006	66	142	720	676	1"
i-BX-(Y) 008	66	332	830	868	1"
i-BX-(Y) 010	66	332	830	868	1"
i-BX-(Y) 013	66	332	830	868	1" 1/4
i-BX-(Y) 015	66	332	830	868	1" 1/4

Dimensions	G	H	L	M	HC
	[mm]	[mm]	[mm]	[mm]	Ø
i-BX-(Y) 020	112	295	830	830	1" 1/4
i-BX-(Y) 025	112	295	830	830	1" 1/4
i-BX-(Y) 030	112	565	1055	1100	1" 1/2
i-BX-(Y) 035	112	565	1055	1100	1" 1/2

19. DIMENSIONAL DRAWINGS

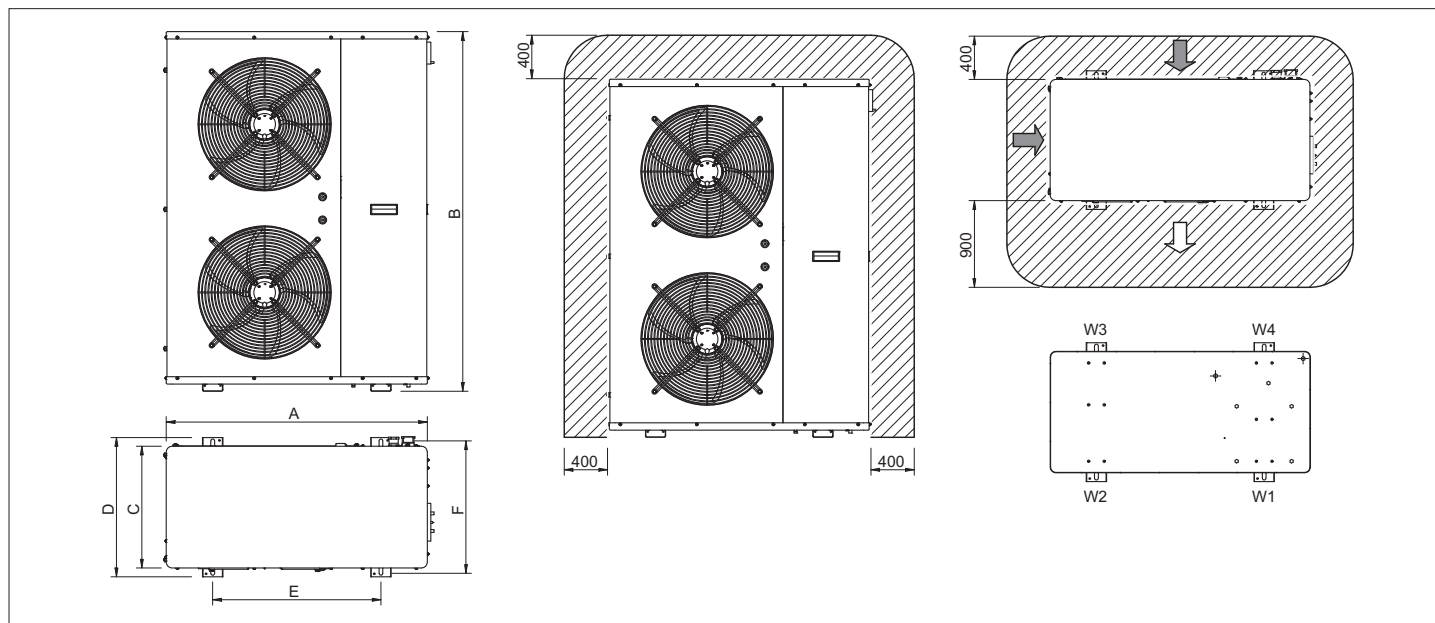

Size	A	B	C	D	E	F	W1	W2	W3	W4	Weight
	[mm]	[mm]	[mm]	[mm]	[mm]	[mm]	[kg]	[kg]	[kg]	[kg]	[kg]
i-BX-(Y) 004	900	940	370	430	580	405	25	12	12	26	75
i-BX-(Y) 006	900	940	370	430	580	405	26	13	14	28	80
i-BX-(Y) 008	900	1240	420	480	580	455	34	19	15	27	95
i-BX-(Y) 010	900	1240	420	480	580	455	40	19	17	34	110
i-BX-(Y) 013	900	1240	420	480	580	455	45	19	18	42	125
i-BX-(Y) 015	900	1240	420	480	580	455	48	16	53	18	135

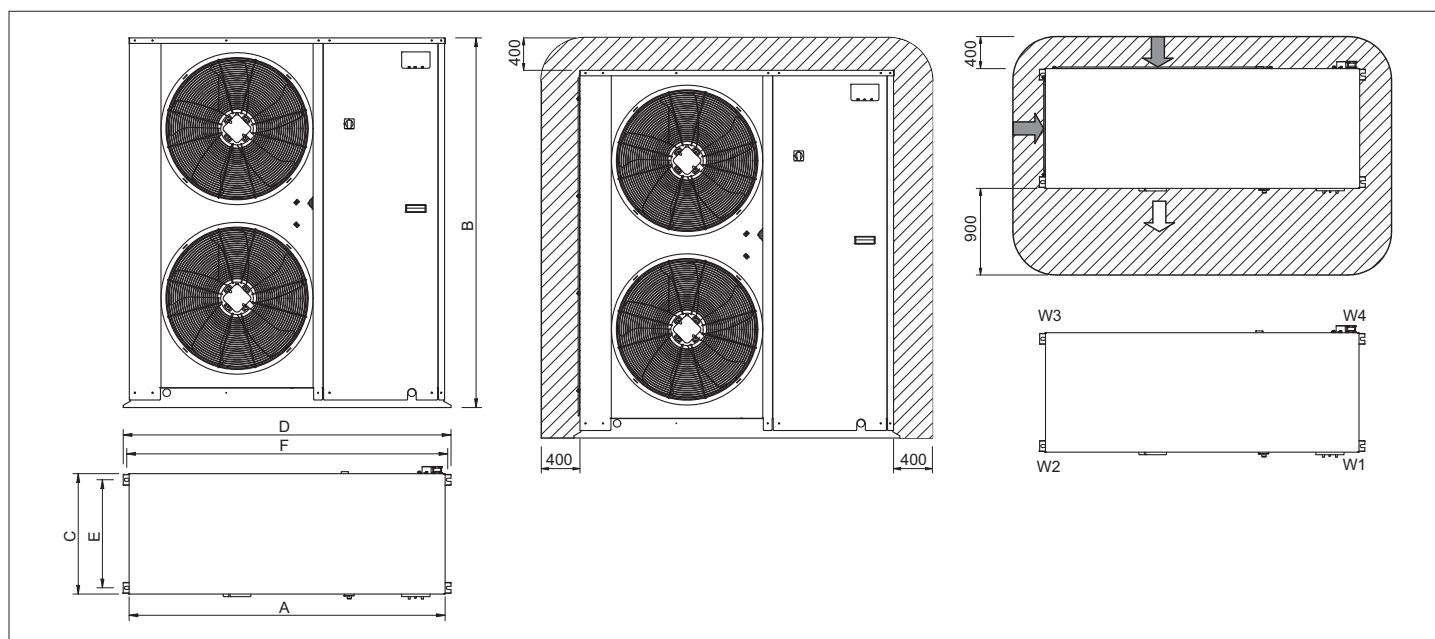

Size	A	B	C	D	E	F	W1	W2	W3	W4	Weight
	[mm]	[mm]	[mm]	[mm]	[mm]	[mm]	[kg]	[kg]	[kg]	[kg]	[kg]
i-BX-(Y) 020	1450	1200	550	1510	500	1480	89	10	82	9	190
i-BX-(Y) 025	1450	1200	550	1510	500	1480	124	16	97	13	250
i-BX-(Y) 030	1450	1700	550	1510	500	1480	134	17	105	14	270
i-BX-(Y) 035	1700	1700	650	1760	600	1730	174	19	101	11	305

HANDLING PACKAGED UNITS

The unit should always be handled by qualified personnel using equipment adequate for the weight of the unit, in compliance with the safety standards in force (and subsequent amendments).

• Lifting by forklift (1)

Insert the forks under the long side of base, opening the forks as far as possible.

• Lifting by crane (2)

To lift the unit, insert tubes long enough to allow positioning of the lifting slings and safety pins in the special feet on the unit. For the sizes of these tubes, see the figures shown in the corresponding section. To avoid the slings damaging the unit, place protection between the slings and the unit.

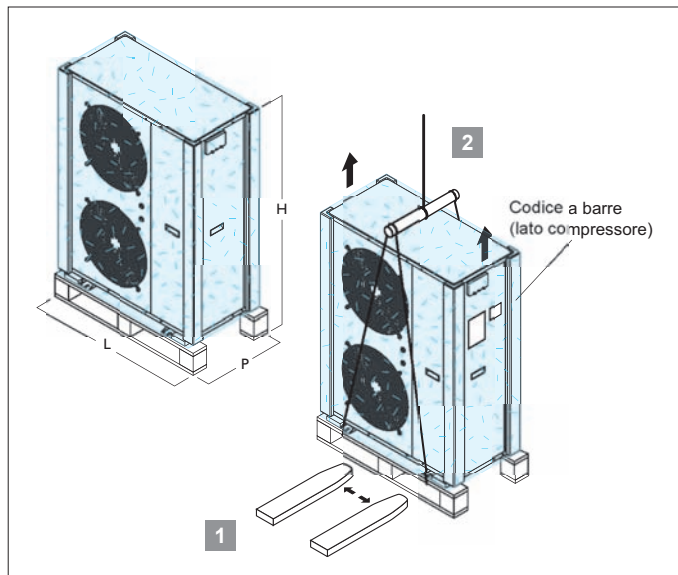

i-BX Dimensions and weight with standard packaging											
Size		04	06	08	10	13	15	20	25	30	35
Dimension L	mm	990	990	990	990	990	990	1530	1530	1530	1780
Dimension P	mm	490	490	540	540	540	540	700	700	700	800
Dimension H	mm	1090	1090	1390	1390	1390	1540	1400	1900	1900	1900
Weight	Kg	90	95	110	125	140	155	210	270	290	325
Max stackable units	n°	1	1	1	1	1	1	1	1	1	1

i-BX Dimensions and weight with wooden crate											
Size		04	06	08	10	13	15	20	25	30	35
Dimension L	mm	1040	1040	1040	1040	1040	1040	1630	1630	1630	1880
Dimension P	mm	545	545	595	595	595	595	750	750	750	850
Dimension H	mm	1170	1170	1470	1470	1470	1620	1450	1950	1950	1950
Weight	Kg	115	120	140	155	170	190	250	320	340	380
Max stackable units	n°	1	1	1	1	1	1	1	1	1	1



for a greener tomorrow

Eco Changes is the Mitsubishi Electric Group's environmental statement, and expresses the Group's stance on environmental management. Through a wide range of businesses, we are helping contribute to the realization of a sustainable society.



MITSUBISHI ELECTRIC HYDRONICS & IT COOLING SYSTEMS S.p.A.

Head Office: M11 - Via Caduti di Cefalonia 1 - 36061 Bassano del Grappa (VI) - Italy

Tel (+39) 0424 509 500 - Fax (+39) 0424 509 509

www.climaveneta.com

www.melcohit.com